

START 489.13

Beechcraft®

Bonanza®

F33A

(Serials CE-674, and After)

F33C ACROBATIC

(Serials CJ-129 and After)
(See Flight Manual Supplement)

Pilot's Operating Handbook

and

FAA Approved Airplane Flight Manual

FAA Approved in Utility Category based on CAR 3. This document must be carried in the airplane at all times and be kept within reach of the pilot during all flight operations.

This handbook includes the material required to be furnished to the pilot by CAR 3.

Airplane Serial Number:

CE R35

Airplane Registration Number:

N230DD

FAA Approved:

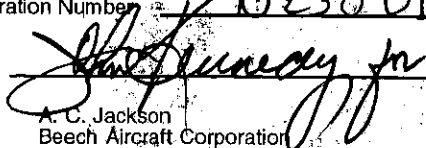

A. C. Jackson
Beech Aircraft Corporation
DOA CE-2

This handbook supersedes all BEECH published owner's manuals, flight manuals, and check lists issued for this airplane with the exception of FAA Approved Airplane Flight Manual Supplements.

COPYRIGHT © BEECH 1994

P/N 33-590009-13
Issued: October, 1976

P/N 33-590009-13A11
Revised: July, 1994

Published By
Commercial Publications
BEECH AIRCRAFT CORPORATION
Wichita, Kansas 67201
U.S.A.

Beechcraft®
A ~~Raytheon~~ Company



Member of GAMA
General Aviation
Manufacturers Association

Bonanza F33A (CE-674 and After)
Pilot's Operating Handbook
and
FAA Approved Airplane Flight Manual

A8 March 1983

LOG OF REVISIONS

PAGES	DESCRIPTION
Title Page	Update
Page A (A8)	New
a & b	Revise "Introduction" and Add "Warning"
2-24A	Revise "Emergency Exit" Placard
3-2	Update Table of Contents
3-3	Add "IAS" Statement and Revise "Emergency Airspeeds"
3-12 & 3-13	Revise "Emergency Exits"
4-3	Add "IAS" Statement and Revise "Air-speeds For Safe Operation"
7-2	Update Table of Contents
7-18 & 7-18A	Revise "Openable Cabin Windows"
7-18B & 7-18C	Revise "Emergency Exits" and Shift Material
8-2	Update Table of Contents
8-25, 8-26, 8-26A & 8-26B	Revise "Magnetos" and "Cleaning - Exterior Painted Surfaces"
8-40, 8-40A, 8-40B & 8-41	Revise "Consumable Materials"

A8

**Bonanza F33A (CE-674 and Alter)
Pilot's Operating Handbook
and
FAA Approved Airplane Flight Manual**

A9 Revision November, 1988

LOG OF REVISIONS

Page	Description
Title Page	Updated
Page A (A9)	
(1 of 2)	New
(2 of 2)	New
2-15	Revised: "Landing Gear"
2-24B	Added: Placard
3-1	Revised: "Table of Contents"
3-7	Revised: "Maximum Glide Configuration" and "Landing Without Power"
3-8	Revised: "Landing Gear Retracted - With Power" and "Propeller Overspeed"
3-8A & 3-8B	Shifted Material
3-11	Revised: "Landing Gear Retraction After Practice Manual Extension"
4-11	Revised: "Before Takeoff"
6-13, 6-14	Revised: "Weight and Balance Loading Form"
7-2	Revised: "Table of Contents"
7-7	Revised: "Typical Instrument Panel"
7-12A	Revised: "Warning Lights (CE-919, CE-923, CE-925, CE-927, CE-929 and after; CJ-156 and after)
7-12B	Revised: "Warning Light Control Switch"
7-12C	Revised: "Control Switch"
7-12D	Revised: "Safety Switches"

A9

LOG OF REVISIONS (Continued)

Page	Description
7-13	Shifted Material
7-14	Revised: "Warning Horn (Serials CE-874 Thru CE-1306, Except CE-1301; CJ-129 Thru CJ-179)" and "Warning Horn and Gear Up Annunciator (Serials CE-1301, CE-1307 and after; CJ-180 and after)"
7-15	Revised: "Baggage Compartment"
7-17	Revised: "Door, Windows and Exits"

A9

**BONANZA F33A (CE-674 AND AFTER)
PILOT'S OPERATING HANDBOOK
AND
FAA APPROVED AIRPLANE FLIGHT MANUAL**

A4 July, 1980

LOG OF REVISIONS

Page	Description
Title Page	Add Revision Date
Page A (A4)	Update
1-1	Revised "Table of Contents"
1-4	Shifted Material
1-5	Revised "Use of the Handbook"
1-6	Shifted Material
1-9	Revised "Descriptive Data"
1-14	Revised "Power" and "Engine Controls And Instruments"
2-4 and 2-5	Revised "Operating Limitations"
2-6 and 2-7	Revised "Power Plant Instrument Markings"
2-12	Revised "Required Equipment for Various Conditions of Flight"
2-24, 2-24A and 2-24B	Revised "Placards"
3-1 and 3-2	Revised "Table of Contents"
3-7	Shifted Material
3-8	Added "Starter Energized Warning Light Illuminated" and Revised "Alternator-Out Procedure"
3-9	Revised "Alternator-Out Procedure"
3-10	Shifted Material
3-12 and 3-13	Revised "Emergency Exit"
3-14	Shifted Material
4-1	Revised "Table of Contents"
4-6 and 4-7	Shifted Material
4-8 and 4-9	Revised "Starting"

A4

**BONANZA F33A (CE-674 AND AFTER)
PILOT'S OPERATING HANDBOOK
AND
FAA APPROVED AIRPLANE FLIGHT MANUAL**

A4 July, 1980

LOG OF REVISIONS

Page	Description
4-10	Revised "Before Takeoff"
4-11	Revised "Before Takeoff" and "Climb"
4-20	Revised "Noise Characteristics"
5-1 and 5-2	Revised "Table of Contents"
5-18B	Revised "Climb"
6-1	Revised "Table of Contents"
6-9	Shifted Material
6-10	Revised "Loading Instructions"
6-11	Shifted Material
7-1 and 7-2	Revised "Table of Contents"
7-9	Shifted Material
7-10 and 7-11	Revised "Manifold Pressure and Fuel Flow Indicator"
7-12	Revised "Manifold Pressure and Fuel Flow Indicator" and "Annunciator System"
7-12A	Revised "Annunciator System" and "Warning Light Control Switch"
7-12B	Shifted Material and Revised "Wing Flaps"
7-18 and 7-18A	Revised "Openable Cabin Windows"
7-18B	Shifted Material
7-19 and 7-20	Shifted Material
7-21	Revised "Starter"
7-22	Shifted Material
7-25	Revised "Battery" and "Alternator"
8-44	Revised "Bulb Replacement Chart"

A4

98-18307

BONANZA F33A (CE-674 AND AFTER)
 PILOT'S OPERATING HANDBOOK
 AND
 FAA APPROVED AIRPLANE FLIGHT MANUAL

A3.....September, 1979

LOG OF REVISIONS

Page	Description
Title Page	Add Revision Date and Letter
Page A (A3)	Update
Page B (A3)	Update
1-1 and 1-2	Revised "Table of Contents"
1-4 and 1-5	Revised "Important Notice" and "Use of the Handbook"
1-9	Revised "Engine" and "Fuel"
1-10	Shifted Material
1-13	Revised "Indicated Pressure Altitude" and "Pressure Altitude"
1-14	Add "Normal Operating Power"
1-15	Revised "Demonstrated Crosswind Velocity"
2-1	Revised "Table of Contents"
2-4	Revised "Airspeed Indicator Markings" and "Power Plant Limitations"
2-5	Shifted Material
2-6	Revised "Tachometer"
2-7	Shifted Material
2-18	Revised "Fuel"
2-21	Revised "Placards"
2-23	Revised "Placards"
4-1	Revised "Table of Contents"
4-7	Revised "External Power"
4-8 and 4-9	Revised "Starting"
4-10	Revised "Before Takeoff"
4-11	Revised "Climb"
4-12	Shifted Material
4-14	Revised "Oxygen System"
4-19 and 4-20	Add "Noise Characteristics"
5-1	Revised "Table of Contents"
5-18B	Add "Climb (3-blade propeller)"
5-19	Revised "Climb (2-blade propeller)"
5-27	Revised "Fuel Flow vs Horsepower" Graph
7-14 and 7-15	Revised "Brakes"
7-21	Revised "Propeller"
7-22	Revised "Fuel Cells"
7-25	Revised "Battery"
7-27	Revised "Exterior Lighting"
7-31	Revised "Oxygen System"

A3

98-38307

A3.....September, 1979

LOG OF REVISIONS

Page	Description
8-5	Revised "Introduction"
8-6	Revised "Publications"
8-14 and 8-15	Revised "Fuel Cells"
8-29	Revised "Nose Gear Retract"
8-31	Revised "Flap Motor and Actuator"
8-32	Revised "Aileron Bell Cranks" and "Elevator Tab Actuator"
8-33	Revised "Main Gear Retract"
8-36 thru 8-39	Revised "Recommended Servicing Schedule"
8-40 and 8-41	Revised "Consumable Materials"
8-44	Revised "Bulb Replacement Chart"
8-46	Revised "Landing Gear"

A3

BONANZA F33A (CE-674 AND AFTER)
 PILOT'S OPERATING HANDBOOK
 AND
 FAA APPROVED AIRPLANE FLIGHT MANUAL
 A2.....September, 1978
 LOG OF REVISIONS

Page	Description
Title Page	Add Revision Date and Letter
1-6A & 1-6B	Add Vender-Issued STC Supplements
1-9	Revised "Engine"
2-3	Revised "Airspeed Limitations"
2-4	Revised "Engine"
2-19	Revised "Placards"
2-20A & 2-20B	Revised Placards
2-24A & 2-24B	Revised Placards
7-12	Revised "Wing Flaps"
7-12A & 7-12B	Revised "Wing Flaps"
7-13	Shifted Material
7-19	Revised "Power Plant"
7-25 & 7-26	Revised "Battery"
7-27	Revised "Exterior Lighting"
7-28	Shifted Material
8-6	Revised "Airplane Inspection Periods"
8-13	Deleted Material

A2

98-38307

BONANZA 133A (CE-674 AND AFTER)
 PILOT'S OPERATING HANDBOOK
 AND
 FAA APPROVED AIRPLANE FLIGHT MANUAL
 A2.....September, 1978

LOG OF REVISIONS

Page	Description
8-24	Revised "Oxygen Cylinder Retesting"
8-26	Revised "Caution"
8-27 & 8-28	Shifted Material
8-29	Revised "Lubrication Points"
8-31	Revised "Lubrication Points"
8-33	Revised "Lubrication Points"
8-38 & 8-39	Revised "Recommended Servicing Schedule"
8-40	Revised "Consumable Materials"
8-42 & 8-43	Revised "Approved Engine Oils"
8-44	Revised "Bulb Replacement Chart"
8-48 & 8-49	Revised "Overhaul or Replacement Schedule"
10-1 to 10-30	Revised "Safety Section"

A2

**BONANZA F33A (CE-674 AND AFTER)
PILOT'S OPERATING HAND BOOK
AND
FAA APPROVED AIRPLANE FLIGHT MANUAL**

A1

November 1977

PAGE	DESCRIPTION OF REVISION
Title Page	Added Revision Date and Letter
1-5	Revised "NOTES"
1-6	Revised "Revising the Handbook"
2-8	Added Limitation
2-22	Deleted Placard
3-4	Revised "After Liftoff and in Flight"
4-7	Added "NOTE"
4-8	Added 28-Volt System
4-9	Shifted Data
5-5	Revised Graph Title
5-9	Expanded Comments Pertinent to Charts
6-3	Changed Airplane Designation
7-25 thru 7-26	Revised "Electrical System"
7-27	Shifted Data
7-33 thru 7-34	Revised "Engine Break-in Information"
8-16	Specified Time Period for First Oil Change
8-17	Revised "Battery" Servicing Procedure
8-18	Corrected Strut Extension Length
8-20	Corrected Insertion Depth
8-21	Revised "Instrument Pressure System"
8-32	Corrected Title of Diagram "H"
8-37	Revised Lubrication Chart to Reflect Changes on page 8-32
8-38	Revised Time Interval and Description of intake Filter
8-39	Revised "NOTE 3"
8-40	Revised "Item - 2"
8-41	Added Footnote
8-44	Added 28-Volt "Replacement Lamps"
10-1 thru 10-34	Replaced With Up-Dated "Safety Informa- tion" Section

A1

November, 1977

Page A

BONANZA F33A (CE-674 AND AFTER)

PILOT'S OPERATING HANDBOOK

and

FAA APPROVED AIRPLANE FLIGHT MANUAL

LOG OF REVISIONS EFFECTIVE PAGE

Original October, 1976

ISSUE OR REV	PAGE	DESCRIPTION OF REVISION
Original	Title Page	See Log of Supplements
Original	"A" Page	
Original	a and b	
Original	1-1 thru 1-17	
Original	2-1 thru 2-26	
Original	3-1 thru 3-13	
Original	4-1 thru 4-19	
Original	5-1 thru 5-32	
Original	6-1 thru 6-17	
Original	7-1 thru 7-34	
Original	8-1 thru 8-50	
Original	Section IX	
Original	10-1 thru 10-33	

A

**BONANZA F33A/F33C
(CE-674 AND AFTER; CJ-129 AND AFTER)
PILOT'S OPERATING HANDBOOK
AND
FAA APPROVED AIRPLANE FLIGHT MANUAL**

A11 Revision July, 1994

LOG OF REVISIONS

Page	Description
Title Page	Updated
Page A (A11)	New
10-1 thru 10-48	Revised Section X, Safety Information (May, 1994)

A11

INTRODUCTION

The format and contents of this Pilot's Operating Handbook and FAA Approved Airplane Flight Manual conform to GAMA (General Aviation Manufacturers Association) Handbook Specification Number 1. Use of this specification by all manufacturers will provide the pilot with the same type of data in the same place in all handbooks.

In recent years, BEECHCRAFT handbooks contained most of the data now provided. However, the new handbooks contain more detailed data and some entirely new data.

For example, attention is called to Section X (SAFETY INFORMATION). While little of the information is new — and every pilot has been exposed to the fundamentals — BEECHCRAFT feels that it is highly important to have Safety Information in a condensed form in the hands of the pilots. The Safety Information should be read and studied. Periodic review will serve as a reminder of good piloting techniques.

BONANZA F33A (CE-674 and after)

PILOT'S OPERATING HANDBOOK

AND

FAA APPROVED AIRPLANE FLIGHT MANUAL

TABLE OF CONTENTS

SECTION 1	GENERAL
SECTION 2	LIMITATIONS
SECTION 3	EMERGENCY PROCEDURES
SECTION 4	NORMAL PROCEDURES
SECTION 5	PERFORMANCE
SECTION 6	WEIGHT AND BALANCE/EQUIPMENT LIST
SECTION 7	SYSTEMS DESCRIPTION
SECTION 8	HANDLING, SERVICING AND MAINTENANCE
SECTION 9	SUPPLEMENTS
SECTION 10	SAFETY INFORMATION

SECTION I

GENERAL

TABLE OF CONTENTS

<i>SUBJECT</i>	<i>PAGE</i>
Introduction.....	1-3
Important Notice.....	1-3
Use of the Handbook.....	1-4
Revising the Handbook.....	1-6
Supplements Revision Record.....	1-6
Vendor-Issued STC Supplements.....	1-6A
Airplane Three View.....	1-7
Ground Turning Clearance.....	1-8
Descriptive Data	
Engine.....	1-9
Propeller.....	1-9
Fuel.....	1-9
Standard System.....	1-9
Optional System.....	1-9
Oil.....	1-10
Oil Capacity.....	1-10
Approved Oil Types.....	1-10
Maximum Certificated Weights.....	1-10
Cabin and Entry Dimensions.....	1-10
Baggage Space and Entry Dimensions.....	1-10
Specific Loadings.....	1-10
Symbols, Abbreviations and Terminology	
General Airspeed.....	1-11
Meteorological.....	1-13
Power.....	1-14
Engine Controls and Instruments.....	1-14
Airplane Performance and Flight Planning.....	1-15
Weight & Balance.....	1-15
July, 1980	1-1

THANK YOU for displaying confidence in us by selecting a BEECHCRAFT airplane. Our design engineers, assemblers and inspectors have utilized their skills and years of experience to ensure that the new BEECHCRAFT Bonanza F33A meets the high standards of quality and performance for which BEECHCRAFT airplanes have become famous throughout the world.

IMPORTANT NOTICE

This handbook should be read carefully by the owner and the operator in order to become familiar with the operation of the Bonanza F33A. Suggestions and recommendations have been made within it to aid in obtaining maximum performance without sacrificing economy. Be familiar with and operate the airplane in accordance with the Pilot's Operating Handbook and FAA Approved Airplane Flight Manual and/or placards which are located in the airplane.

As a further reminder, the owner and the operator should also be familiar with the Federal Aviation Regulations applicable to the operation and maintenance of the airplane, and FAR Part 91 General Operating and Flight Rules. Further, the airplane must be operated and maintained in accordance with FAA Airworthiness Directives which may be issued against it.

The Federal Aviation Regulations place the responsibility for the maintenance of this airplane on the owner and the operator, who should ensure that all maintenance is done by qualified mechanics in conformity with all airworthiness requirements established for this airplane.

All limits, procedures, safety practices, time limits, servicing, and maintenance requirements contained in this handbook are considered mandatory for continued airworthiness to

Section I
General

BEECHCRAFT Bonanza F33A
CE-674 and after

maintain the airplane in a condition equal to that of its original manufacture.

Authorized BEECHCRAFT Aero Centers, Aviation Centers, International Distributors and International Dealers can provide recommended modification, service, and operating procedures issued by both the FAA and Beech Aircraft Corporation, which are designed to get maximum utility and safety from the airplane.

USE OF THE HANDBOOK

The Pilot's Operating Handbook is designed to maintain documents necessary for the safe and efficient operation of the Bonanza F33A. The handbook has been prepared in loose leaf form for ease in maintenance and in a convenient size for storage. The handbook has been arranged with quick reference tabs imprinted with the title of each section and contains ten basic divisions:

Section I	General
Section II	Limitations
Section III	Emergency Procedures
Section IV	Normal Procedures
Section V	Performance
Section VI	Weight and Balance/Equipment List
Section VII	Systems Description
Section VIII	Handling, Servicing and Maintenance
Section IX	Supplements
Section X	Safety Information

NOTE

Except as noted, all airspeeds quoted in this handbook are Indicated Airspeeds (IAS) and assume zero instrument error.

NOTES

In an effort to provide as complete coverage as possible, applicable to any configuration of the airplane, some optional equipment has been included in the scope of the manual. However, due to the variety of airplane appointments and arrangements available, optional equipment described or depicted herein may not be designated as such in every case.

Neither Service Publications, Reissues nor Revisions are automatically provided to the holder of this handbook. For information on how to obtain "Revision Service" applicable to this handbook, consult a BEECHCRAFT Aero Center, Aviation Center, International Distributor or International Dealer, or refer to the latest revision of BEECHCRAFT Service Instructions No. 0250-010.

Beech Aircraft Corporation expressly reserves the right to supersede, cancel, and/or declare obsolete, without prior notice, any part, part number, kit, or publication referenced in this manual.

The owner/operator should always refer to all supplements, whether STC Supplements or Beech Supplements, for possible placards, limitations, normal, emergency and other operational procedures for proper operation of the airplane with optional equipment installed.

REVISING THE HANDBOOK

Immediately following the Title Page is the "Log of Revisions" page(s). The Log of Revisions pages are used for maintaining a listing of all effective pages in the handbook (except the SUPPLEMENTS Section), and as a record of revisions to these pages. In the lower right corner of the outlined portion is a box containing a capital letter which denotes the issue or reissue of the handbook. It will be advanced one letter, alphabetically, per reissue. This letter will be suffixed by a number whenever the handbook is revised. When a revision to the handbook is made, a new Log of Revisions will be issued. All Log of Revisions must be retained in the handbook to provide a complete record of material status until a reissue is made.

WARNING

When this handbook is used for airplane operational purposes it is the pilot's responsibility to maintain it in current status.

SUPPLEMENTS REVISION RECORD

Section IX contains supplements and a Log of Supplements page. On the "Log" page is a listing of supplemental equipment available for installation on the BEECHCRAFT Bonanza F33A. When new supplements are received or existing supplements revised, a new "Log" page will replace the previous one, since it contains a listing of all previous supplements plus the new supplements. The supplemental material will be added to the grouping in accordance with the descriptive listing.

VENDOR-ISSUED STC SUPPLEMENTS

When a new airplane is delivered from the factory, the handbook delivered with it contains either an STC (Supplemental Type Certificate) Supplement or a Beech Flight Manual Supplement for every installed item requiring a supplement. If a new handbook for operation of the airplane is obtained at a later date, it is the responsibility of the owner/operator to ensure that all required STC Supplements (as well as weight and balance and other pertinent data) are transferred into the new handbook.

BEEHCRAFT Bonanza F33A
CE-674 and after

Section I
General

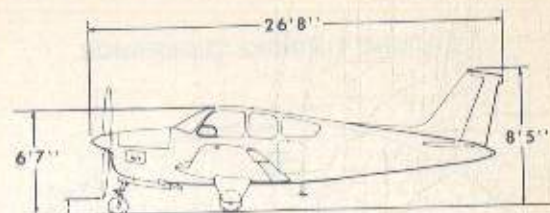

7.5'
MINIMUM
CLEARANCE

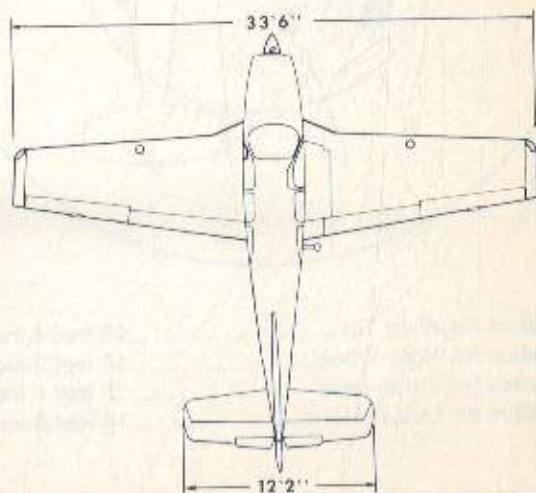
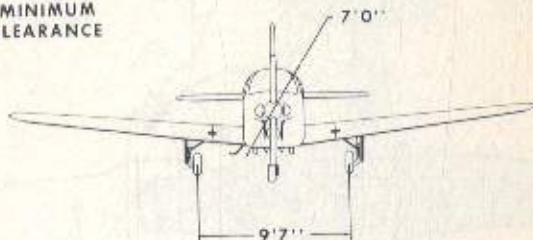

THREE VIEW

F33A-807-5

GROUND TURNING CLEARANCE

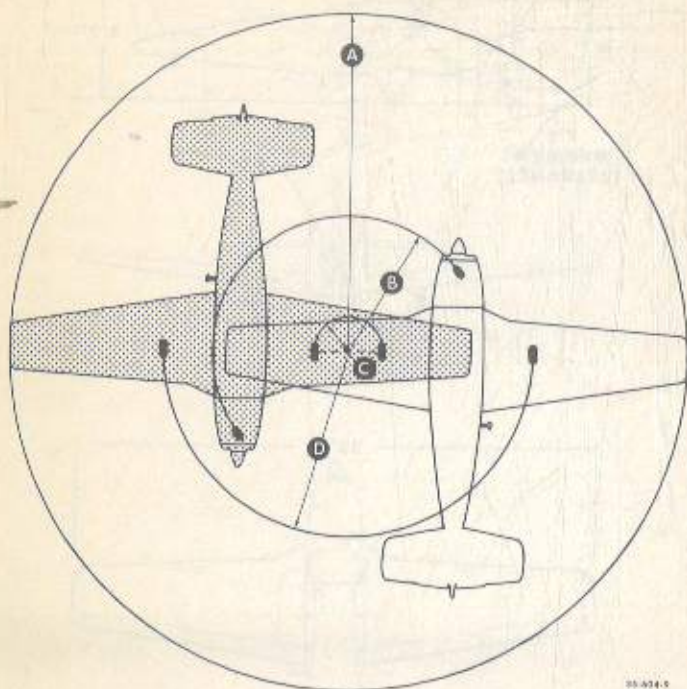

35-934-9

- A Radius for Wing Tip26 feet 4 inches
- B Radius for Nose Wheel12 feet 2 inches
- C Radius for Inside Gear 5 feet 1 inch
- D Radius for Outside Gear14 feet 8 inches

TURNING RADII ARE CALCULATED USING FULL STEERING,
ONE BRAKE AND PARTIAL POWER.

DESCRIPTIVE DATA

ENGINE

One Teledyne Continental Motors Corporation engine model IO-520-BA or IO-520-BB. These are fuel-injected, direct-drive, air-cooled, horizontally opposed, 6-cylinder, 520-cubic-Inch-displacement, 285-horsepower-rated engines.

Take-off and Maximum

Continuous Power..... Full Throttle, 2700 rpm

Maximum Normal Operating Power

Serials CE-891 and after with

2-Blade Propeller Installed, and

Serials CJ-156 and after with 2-Blade

Propeller Installed Full Throttle, 2550 rpm

PROPELLER

One McCauley constant-speed, 2-blade propeller using 2A36C23 hub with 84B-0 blades, or McCauley constant-speed, 3-blade propeller using 3A32C76 hub with 82NB-2 blades.

FUEL

Aviation Gasoline 100LL (blue), or 100/130 (green) minimum grade.

STANDARD SYSTEM (CE-674 thru CE-883) (CJ-129 thru CJ-155)

Total Capacity 50 Gallons

Total Usable 44 Gallons

STANDARD SYSTEM (CE-884 and after) (CJ-156 and after)

OPTIONAL SYSTEM (CE-674 thru CE-883) (CJ-129 thru CJ-155)

Total Capacity 80 Gallons

Total Usable 74 Gallons

**Section I
General**

**BEECHCRAFT Bonanza F33A
CE-674 and after**

OIL

OIL CAPACITY

Total 12 Quarts

APPROVED OIL TYPES

Ashless dispersant oils meeting the requirements of Teledyne Continental Motors Corporation Specification MHS-24A. Refer to **HANDLING, SERVICING AND MAINTENANCE** Section for a list of oils meeting this specification.

MAXIMUM CERTIFICATED WEIGHTS

Maximum Ramp Weight..... 3412 lbs
Maximum Take-off Weight 3400 lbs
Maximum Landing Weight..... 3400 lbs
Maximum Zero Fuel Weight..... No Structural Limit
Maximum Weight in Baggage Compartment..... 270 lbs

CABIN AND ENTRY DIMENSIONS

Cabin Width (maximum)..... 3 ft 6 in.
Cabin Length (maximum)..... 10 ft 1 in.
Cabin Height (maximum)..... 4 ft 2 in.
Cabin Door..... 37 in. wide by 36 in. high

BAGGAGE SPACE AND ENTRY DIMENSIONS

Compartment Volume 35 cu ft
Door Width (minimum)..... 18.5 in.
Door Height (minimum)..... 22.5 in.
Volume Above Hat Shelf..... 1.7 cu ft

SPECIFIC LOADINGS

Wing Loading at Maximum Take-off Weight...18.8 lbs/sq ft
Power Loading at Maximum Take-off Weight...15.9 lbs/hp

SYMBOLS, ABBREVIATIONS AND TERMINOLOGY

GENERAL AIRSPEED

- CAS** Calibrated Airspeed is the indicated speed of an airplane, corrected for position and instrument error. Calibrated airspeed is equal to true airspeed in standard atmosphere at sea level.
- KCAS** Calibrated Airspeed expressed in knots.
- GS** Ground Speed is the speed of an airplane relative to the ground.
- IAS** Indicated Airspeed is the speed of an airplane as shown on the airspeed indicator when corrected for instrument error. IAS values published in this handbook assume zero instrument error.
- KIAS** Indicated Airspeed expressed in knots.
- TAS** True Airspeed is the airspeed of an airplane relative to undisturbed air which is the CAS corrected for altitude, temperature, and compressibility.
- V_A** Maneuvering Speed is the maximum speed at which application of full available aerodynamic control will not overstress the airplane.
- V_{FE}** Maximum Flap Extended Speed is the highest speed permissible with wing flaps in a prescribed extended position.

- V_{LE} Maximum Landing Gear Extended Speed is the maximum speed at which an airplane can be safely flown with the landing gear extended.
- V_{LO} Maximum Landing Gear Operating Speed is the maximum speed at which the landing gear can be safely extended or retracted.
- V_{NE} Never Exceed Speed is the speed limit that may not be exceeded at any time.
- V_{NO}
or
 V_C Maximum Structural Cruising Speed is the speed that should not be exceeded except in smooth air and then only with caution.
- V_S Stalling Speed or the minimum steady flight speed at which the airplane is controllable.
- V_{SO} Stalling Speed or the minimum steady flight speed at which the airplane is controllable in the landing configuration.
- V_X Best Angle-of-Climb Speed is the airspeed which delivers the greatest gain of altitude in the shortest possible horizontal distance.
- V_Y Best Rate-of-Climb Speed is the airspeed which delivers the greatest gain in altitude in the shortest possible time.

METEOROLOGICAL

ISA International Standard Atmosphere in which:

- (1) The air is a dry perfect gas;
- (2) The temperature at sea level is 15° Celsius (59° Fahrenheit);
- (3) The pressure at sea level is 29.92 inches Hg (1013.2 millibars);
- (4) The temperature gradient from sea level to the altitude at which the temperature is -56.5°C (-69.7°F) is -0.00198°C ($-0.003566^{\circ}\text{F}$) per foot and zero above that altitude.

OAT Outside Air Temperature is the free air static temperature, obtained either from inflight temperature indications adjusted for instrument error and compressibility effects or ground meteorological sources.

Indicated Pressure Altitude The number actually read from an altimeter when the barometric subscale has been set to 29.92 inches of mercury (1013.2 millibars)

Pressure Altitude Altitude measured from standard sea-level pressure (29.92 in. Hg) by a pressure or barometric altimeter. It is the indicated pressure altitude corrected for position and instrument error. In this handbook, altimeter instrument errors are assumed to be zero. Position errors may be obtained from the Altimeter Correction graph.

**Section I
General**

**BEECHCRAFT Bonanza F33A
CE-674 and after**

Station Pressure Actual atmospheric pressure at field elevation.

Wind The wind velocities recorded as variables on the charts of this handbook are to be understood as the headwind or tailwind components of the reported winds.

POWER

Take-off and Maximum Continuous Highest power rating not limited by time.

Maximum Normal Operating Power (MNOP) Highest power rating within the normal operating range. Noise characteristics requirements of FAR 36 have been demonstrated at this power rating.

Cruise Climb Power recommended for cruise climb.

ENGINE CONTROLS AND INSTRUMENTS

Throttle Control Used to control power by introducing fuel-air mixture into the intake passages of the engine. Settings are reflected by readings on the manifold pressure gage.

Propeller Control This control requests the propeller governor to maintain engine/propeller rpm at a selected value by controlling propeller blade angle.

Mixture Control This control is used to set fuel flow in all modes of operation and cuts off fuel completely for engine shut down.

EGT (Exhaust Gas Temperature) Indicator This indicator is used to identify the lean and best power fuel flow mixtures for various power settings during cruise.

Tachometer	Indicates the rpm of the engine/propeller.
Propeller Governor	Regulates the rpm of the engine/propeller by increasing or decreasing the propeller pitch through a pitch change mechanism in the propeller hub.

AIRPLANE PERFORMANCE AND FLIGHT PLANNING

Climb Gradient The ratio of the change in height during a portion of a climb, to the horizontal distance traversed in the same time interval.

Demonstrated Crosswind Velocity The demonstrated crosswind velocity is the velocity of the crosswind component for which adequate control of the airplane during take off and landing was actually demonstrated during certification tests. The value shown is not limiting.

MEA Minimum enroute IFR altitude.

Route Segment A part of a route. Each end of that part is identified by: (1) a geographical location; or (2) a point at which a definite radio fix can be established.

GPH U.S. Gallons per hour.

WEIGHT & BALANCE

Reference Datum An imaginary vertical plane from which all horizontal distances are measured for balance purposes.

**Section I
General**

**BEECHCRAFT Bonanza F33A
CE-674 and after**

Station	A location along the airplane fuselage usually given in terms of distance from the reference datum.
Arm	The horizontal distance from the reference datum to the center of gravity (C.G.) of an item.
Moment	The product of the weight of an item multiplied by its arm (Moment divided by a constant is used to simplify balance calculations by reducing the number of digits.)
Airplane Center of Gravity (CG)	The point at which an airplane would balance if suspended. Its distance from the reference datum is found by dividing the total moment by the total weight of the airplane.
CG Arm	The arm obtained by adding the airplane's individual moments and dividing the sum by the total weight.
CG Limits	The extreme center of gravity locations within which the airplane must be operated at a given weight.
Usable Fuel	Fuel available for flight planning.
Unusable Fuel	Fuel remaining after a runout test has been completed in accordance with governmental regulations.
Standard Empty Weight	Weight of a standard airplane including unusable fuel, full operating fluids and full oil.

Basic Empty Weight	Standard Empty Weight plus optional equipment.
Payload	Weight of occupants, cargo and baggage.
Useful Load	Difference between Take-off Weight (or Ramp Weight, if applicable) and Basic Empty Weight.
Maximum Ramp Weight	Maximum weight approved for ground maneuvering. (It includes weight of start, taxi, and take-off fuel)
Maximum Take-off Weight	Maximum weight approved for liftoff.
Maximum Landing Weight	Maximum weight approved for the landing touchdown.
Maximum Zero Fuel Weight	Maximum weight exclusive of usable fuel.
Tare	The weight of chocks, blocks, stands, etc., used on the scales when weighing an airplane.
Leveling Points	Those points which are used during the weighing process to level the airplane.
Jack Points	Points on the airplane identified by the manufacturer as suitable for supporting the airplane for weighing or other purposes.

SECTION II

LIMITATIONS

TABLE OF CONTENTS

<i>SUBJECT</i>	<i>PAGE</i>
Airspeed Limitations	2-3
Airspeed Indicator Markings.....	2-4
Power Plant Limitations	
Engine.....	2-4
Operating Limitations	2-4
Fuel Grades.....	2-5
Oil Specifications	2-5
Propeller Specifications	2-5
Power Plant Instrument Markings.....	2-6
Miscellaneous Instrument Markings	2-7
Weight Limits	2-7
Center of Gravity Limits.....	2-7
Reference Datum.....	2-7
Maneuver Limits.....	2-8
Approved Maneuvers (3400 Pounds).....	2-8
Flight Load Factor Limits (3400 Pounds).....	2-8
Minimum Flight Crew	2-8
Kinds of Operation Limits.....	2-8
Required Equipment for Various Conditions of Flight.....	2-9
Fuel	
Total Fuel	2-18
Standard Fuel System	2-18
Optional Fuel System	2-18
Fuel Management.....	2-18
Seating	2-18
Placards.....	2-19

**Section II
Limitations**

**BEEHCRAFT Bonanza F33A
CE-674 and after**

The limitations included in this section have been approved by the Federal Aviation Administration and must be observed in the operation of this airplane.

**Section II
Limitations**

**BEECHCRAFT Bonanza F3JA
CE-674 and after**

***AIRSPEED INDICATOR MARKINGS**

MARKING	KCAS VALUE OR RANGE	KIAS VALUE OR RANGE	SIGNIFICANCE
White Arc	53-122	52-123	Full Flap Operating Range
White Triangle**	152	154	Maximum Speed for Approach Flaps
Green Arc	64-165	64-167	Normal Operat- ing Range
Yellow Arc	165-195	167-196	Operate With Caution, Only in Smooth Air
Red Line	195	196	Maximum Speed For All Operations

*The airspeed indicator is marked in IAS values.
**Serials CE-884 and after, and CJ-156 and after.

POWER PLANT LIMITATIONS

ENGINE

One Teledyne Continental Motors Corporation's model IO-520-BA or IO-520-BB engine.

OPERATING LIMITATIONS

Take-off and Maximum

Continuous Power Full Throttle, 2700 rpm

Maximum Normal Operating Power

Serials CE-891 and after with 2-blade Propeller In-
stalled and Serials CJ-156 and after with 2-blade
Propeller Installed Full Throttle, 2550 rpm

AIRSPPEED LIMITATIONS

SPEED	KCAS	KIAS	REMARKS
Never Exceed V_{NE} <i>RED LINE</i>	195	196	Do Not Exceed This Speed in Any Operation.
Maximum Structural Cruising V_{NO} or V_C <i>YELLOW ARC</i>	165	167	Do Not Exceed This Speed Except in Smooth Air and Then Only With Caution.
Maneuvering V_A <i>SUBS. TO WEIGHT</i>	132	134	Do Not Make Full or Abrupt Control Movements Above This Speed.
Maximum Flap Extension/ Extended V_{FE} (Prior to CE-816 and CJ-150) (CE-816 and after, CJ-150 and after)	122 <i>TOP OF WHITE ARC.</i>	123	Do Not Extend Flaps or Operate With Flaps Extended Above This Speed.
Approach (15°) <i>→</i> Full Down (30°) <i>←</i>	152 122	154 123	
Maximum Landing Gear Operating/Extended V_{LO}/V_{LE}	152	154	Do Not Extend, Retract or Operate With Gear Extended Above This Speed, Except in Emergency.

120
125
130
134

**BEECHCRAFT Bonanza F33A
CE-674 and after**

**Section II
Limitations**

Cylinder Head Temperature.....	238° C
Oil Temperature.....	116° C
Oil Pressure	
Minimum	30 psi
Maximum	100 psi
Fuel Pressure	
Serials CE-674 thru CE-928; CJ-129 thru CJ-155:	
Minimum	1.5 psi
Maximum	17.5 psi
Fuel Flow	
Serials CE-929 and after; CJ-156 and after:	
Maximum	24.3 gph

FUEL GRADES

Aviation Gasoline 100LL (blue) or 100/130 (green) minimum grade.

OIL SPECIFICATIONS

Ashless dispersant oils meeting Teledyne Continental Motors Corporation Specification MHS-24B. Refer to the Approved Engine Oils table in the HANDLING, SERVICING AND MAINTENANCE Section for a list of approved brands.

PROPELLER SPECIFICATIONS

McCauley constant speed two-blade propeller using 2A36C23 hub with 84B-0 blades. Pitch setting at 30 inch station; low 13.3°, high 29.2°. Diameter is: Maximum 84 in., Minimum 82 in. - or, McCauley constant speed three-blade propeller using 3A32C76 hub with 82NB-2 blades. Pitch setting at 30 inch station; low 13.3°, high 29.0°. Diameter is: Maximum 80 in., Minimum 78-1/2 in.

Section II
Limitations

BEECHCRAFT Bonanza F33A
CE-674 and after

POWER PLANT INSTRUMENT MARKINGS

OIL TEMPERATURE

Caution (Yellow Radial).....38°C
Operating Range
(Green Arc).....38° to 116°C
Maximum (Red Radial).....116°C

OIL PRESSURE

Minimum Pressure (Red Radial).....30 psi
Operating Range (Green Arc).....30 to 60 psi
Maximum Pressure (Red Radial).....100 psi

TACHOMETER

Operating Range (Green Arc)

(Serials CE-674 thru CE-890 with 2- or 3-Blade Propeller Installed and CE-891 and after with 3-Blade Propeller Installed)

(Serials CJ-129 thru CJ-155 with 2- or 3-Blade Propeller Installed and CJ-156 and after with 3-Blade Propeller Installed)..... 1800 to 2700 rpm

Operating Range (Green Arc)

(Serials CE-891 and after with 2-Blade Propeller Installed)

(Serials CJ-156 and after with 2-Blade Propeller Installed)..... 1800 to 2550 rpm

Maximum rpm (Red Radial).....2700 rpm

CYLINDER HEAD TEMPERATURE

Operating Range

(Green Arc).....93° to 238°C
Maximum Temperature (Red Radial).....238°C

MANIFOLD PRESSURE

Operating Range (Green Arc).....15 to 29.6 in. Hg
Maximum (Red Radial).....29.6 in. Hg

FUEL FLOW

Serials CE-674 thru CE-928; CJ-129 thru CJ-155:

Minimum (Red Radial)..... 1.5 psi

Operating Range (Green Arc)	6.9 to 24.3 gph
Maximum (Red Radial)	17.5 psi
Serials CE-929 and after; CJ-156 and after:	
Operating Range (Green Arc)	6.9 to 24.3 gph
Maximum (Red Radial)	24.3 gph

MISCELLANEOUS INSTRUMENT MARKINGS

INSTRUMENT PRESSURE

Operating Range (Green Arc).....4.3 to 5.9 in. Hg

FUEL QUANTITY

Yellow BandE to 1/2 full (44-gallon system)

Yellow BandE to 3/4 full (74-gallon system)

WEIGHT LIMITS

Maximum Ramp Weight3412 lbs

Maximum Take-off Weight.....3400 lbs

Maximum Landing Weight.....3400 lbs

Zero Fuel Weight.....No Structural Limitation

Maximum Baggage Compartment Load.....270 lbs

CENTER OF GRAVITY LIMITS (Landing Gear Extended)

FORWARD LIMITS

77.0 inches aft of datum to 2800 pounds with straight line variation to 82.1 inches at 3400 pounds.

AFT LIMITS

86.7 inches aft of datum at all weights.

REFERENCE DATUM

Datum is 83.1 inches forward of center line through forward jack points.

MAC leading edge is 66.7 inches aft of datum.

MAC length is 65.3 inches.

**Section II
Limitations**

**BEECHCRAFT Bonanza F33A
CE-674 and after**

MANEUVER LIMITS

This is a utility category airplane. Spins are prohibited. No acrobatic maneuvers are approved except those listed below. Maximum slip duration is 30 seconds.

APPROVED MANEUVERS (3400 POUNDS)

MANEUVER	ENTRY SPEED	
	KCAS	KIAS
Chandelle	132	134
Steep Turn	132	134
Lazy Eight	132	134
Stall (Except Whip)	Use Slow Deceleration	

Minimum fuel for above maneuvers-10 gallons each main tank

FLIGHT LOAD FACTOR LIMITS (3400 POUNDS)

Positive Maneuvering Load Factors:

Flaps Up 4.4 G
Flaps Down 2.0 G

MINIMUM FLIGHT CREW

One (1) Pilot

KINDS OF OPERATION LIMITS

1. VFR day and night
2. IFR day and night

REQUIRED EQUIPMENT FOR VARIOUS CONDITIONS OF FLIGHT

Federal Aviation Regulations (91.3(a), 91.24, 91.25, 91.32, 91.33, 91.52, 91.90, 91.97, 91.170) specify the minimum numbers and types of airplane instruments and equipment which must be installed and operable for various kinds of flight conditions. This includes VFR day, VFR night, IFR day, and IFR night.

Regulations also require that all airplanes be certificated by the manufacturer for operations under various flight conditions. At certification, all required equipment must be in operating condition and should be maintained to assure continued airworthiness. If deviations from the installed equipment were not permitted, or if the operating rules did not provide for various flight conditions, the airplane could not be flown unless all equipment was operable. With appropriate limitations, the operation of every system or component installed in the airplane is not necessary, when the remaining operative instruments and equipment provide for continued safe operation. Operation in accordance with limitations established to maintain airworthiness can permit continued or uninterrupted operation of the airplane temporarily.

For the sake of brevity, the Required Equipment Listing does not include obviously required items such as wings, rudders, flaps, engine, landing gear, etc. Also the list does not include items which do not affect the airworthiness of the airplane such as galley equipment, entertainment systems, passenger convenience items, etc. However, it is important to note that ALL ITEMS WHICH ARE RELATED TO THE AIRWORTHINESS OF THE AIRPLANE AND NOT INCLUDED ON THE LIST ARE AUTOMATICALLY REQUIRED TO BE OPERATIVE.

To enable the pilot to rapidly determine the FAA equipment requirements necessary for a flight into specific conditions, the following equipment requirements and exceptions are presented. It is the final responsibility of the pilot to determine whether the lack of, or inoperative status of a piece of equipment on his airplane, will limit the conditions under which he may operate the airplane.

WARNING

FLIGHT IN KNOWN ICING CONDITIONS IS PROHIBITED.

LEGEND

- (-) Indicates that the item may be inoperative for the specified condition.
- (*) Refers to the REMARKS AND/OR EXCEPTIONS column for explicit information or reference.

SYSTEM and/or COMPONENT	VFR Day			Remarks and/or Exceptions
	VFR Night	IFR Day	IFR Night	
	*	*	*	
GENERAL OVERWATER FLIGHT	*	*	*	-*Per FAR 91.33
ATA 100 CHAPTER 23 COMMUNICATIONS				
VHF communications system	*	*	*	-*Per FAR 91.33
ATA 100 CHAPTER 24 ELECTRICAL POWER				
Battery	1	1	1	
DC alternator	1	1	1	
DC alternator out indica- tor light	1	1	1	- May be inoperative providing ammeter is operative and monitored.
Standby generator	*	*	*	-*Optional

Section II
Limitations

BEECHCRAFT Bonanza F33A
CE-674 and after

SYSTEM and/or COMPONENT	VFR Day			VFR Night			IFR Day			IFR Night		
										Remarks and/or Exceptions		
ATA 100 CHAPTER 24 ELECTRICAL POWER (cont'd) Starter Energized Warning Light (CE-919, CE-923, CE-925, CE-927, CE-929 and after, CJ-156 and after)	1	1	1	1	1	1	1	1	1	1	1	1
ATA 100 CHAPTER 25 EQUIPMENT AND FURNISHING Seat belts and Shoulder harnesses Emergency locator transmitter	1	1	1	1	1	1	1	1	1	1	1	1
ATA 100 CHAPTER 26 FIRE PROTECTION Portable fire extinguisher	1	1	1	1	1	1	1	1	1	1	1	1

ATA 100 CHAPTER 27 FLIGHT CONTROLS						
Elevator trim tab indicator	1	1	1	1	1	- May be inoperative for ferry flight provided tabs are visually checked in the neutral position prior to takeoff and checked for full range of operation.
Flap position indicator	1	1	1	1	1	- May be inoperative providing flap travel is visually inspected prior to takeoff.
Stall warning	1	1	1	1	1	-
ATA 100 CHAPTER 28 FUEL EQUIPMENT						
Auxiliary fuel pump	1	1	1	1	1	-
Engine driven fuel pump	1	1	1	1	1	-

SYSTEM and/or COMPONENT	VFR Day			Remarks and/or Exceptions
	VFR Day	VFR Night	IFR Day	
	IFR Day	IFR Night	IFR Night	
ATA 100 CHAPTER 28 FUEL EQUIPMENT (Cont'd)				
Fuel quantity indicator	2	2	2	One may be inoperative provided other side is operational and amount of fuel on board can be established to be adequate for the intended flight.
Fuel flow indicator	1	1	1	
ATA 100 CHAPTER 30 ICE AND RAIN PROTECTION				
Emergency static air source	+	*	*	-*Optional
Pitot heater	*	*	1	-*Optional

LANDING GEAR									
Landing gear motor	1	1	1	1	1	1	1	1	1
Gear Up Annunciator	1	1	1	1	1	1	1	1	1
Landing gear position lights		4	4	4	4	4	4	4	4
Landing gear warning horn		1	1	1	1	1	1	1	1
LIGHTS									
Cockpit and instrument lights	-	*	-	-	-	-	-	*	* Lights must be operative.
Taxi light	-	-	-	-	-	-	-	-	-
Landing light	-	*	-	-	-	-	-	*	* Per FAR 91
Rotating beacon	*	1	*	1	*	1	*	1	* Optional
Position light	-	3	-	-	-	-	-	3	-

Section II
Limitations

BEECHCRAFT Bonanza F33A
CE-674 and after

SYSTEM and/or COMPONENT	VFR Day			VFR Night			Remarks, and/or Exceptions
	VFR Day		VFR Night		IFR Day		
	1	2	1	2	1	2	
NAVIGATION INSTRUMENTS							
Altimeter	1		1		1		
Airspeed indicator	1		1		1		
Vertical speed	-		-		-		
Magnetic compass	1		1		1		
Attitude indicator	-		-		-		
Turn and slip indicator	-		-		-		
Directional gyro	-		-		-		
Clock	-		-		-		
Transponder	*		+		*		*Per FAR 91
Navigation equipment	-		-		-		*Per FAR 91
OXYGEN							
Oxygen system.	*		+		+		*Per FAR 91

ATA 100 CHAPTER 36 PNEUMATIC						
Pressure system for instrument air	-	-	1	1	1	-
Pressure gage	-	-	1	1	1	-
ATA 100 CHAPTER 77 ENGINE INDICATING INSTRUMENTS						
Engine tachometer indicator	1	1	1	1	1	-
Exhaust gas temperature indicator	*	*	*	*	*	* - *Optional
Manifold pressure indicator	1	1	1	1	1	-
ATA 100 CHAPTER 79 ENGINE OIL INSTRUMENTS						
Oil pressure indicator	1	1	1	1	1	-
Oil temperature indicator	1	1	1	1	1	-

**Section II
Limitations**

**BEECHCRAFT Bonanza F33A
CE-674 and after**

FUEL

TOTAL FUEL with left and right wing fuel systems full:

Standard Fuel System (CE-674 thru CE-883) (CJ-129 thru CJ-156)

Capacity 50 gallons

Usable 44 gallons

Standard Fuel System (CE-884 and after, and CJ-156 and after)

Optional Fuel System (CE-674 thru CE-883, and CJ-129 thru CJ-156)

Capacity 80 gallons

Usable 74 gallons

FUEL MANAGEMENT

Do not take off when Fuel Quantity Gages indicate in Yellow Band or with less than 13 gallons in each wing fuel system.

Maximum slip duration is 30 seconds.

SEATING

All occupied seats must be in the upright position for takeoff and landing.

PLACARDS

On Left Side Panel (Airspeed Values are IAS): (Prior to CE-816 and CJ-150)

AIR SPEED LIMITATION
MAXIMUM SPEED WITH LANDING GEAR EXTENDED (NORMAL) 154 KNOTS. MAXIMUM DESIGN MANEUVERING SPEED 134 KNOTS.
UTILITY CATEGORY AIRPLANE
OPERATE IN ACCORDANCE WITH FAA APPROVED AIRPLANE FLIGHT MANUAL.
INTENTIONAL SPINS PROHIBITED
NO ACROBATIC MANEUVERS APPROVED EXCEPT THOSE LISTED IN THE AIRPLANE FLIGHT MANUAL.

On Left Side Panel (Airspeed Values are IAS): (CE-816 and after, CJ-150 and after)

AIR SPEED LIMITATION
MAX. LDG GEAR EXTENDED (NORMAL) --- 154 KTS MAX. APPROACH FLAPS (15°)-----154 KTS MAX. FULL DOWN FLAPS (30°)-----123 KTS MAX. MANEUVERING-----134 KTS
UTILITY CATEGORY AIRPLANE
OPERATE IN ACCORDANCE WITH FAA APPROVED AIRPLANE FLIGHT MANUAL.
INTENTIONAL SPINS PROHIBITED
NO ACROBATIC MANEUVERS APPROVED EXCEPT THOSE LISTED IN THE AIRPLANE FLIGHT MANUAL.

**Section II
Limitations**

**BEECHCRAFT Bonanza F33A
CE-674 and after**

On Left Side Panel Near Firewall Air Controls:

⊕ **IN CASE OF ENGINE FIRE
PULL FIREWALL AIR
CONTROL TO CLOSE** ⊕

*On Top of Front Spar Carry-thru Structure Between Front
Seats:*

**EMERGENCY
LANDING GEAR
INSTRUCTIONS
TO EXTEND**

⊕ ⊕

**ENGAGE HANDLE IN REAR
OF FRONT SEAT AND TURN
COUNTERCLOCKWISE AS FAR
AS POSSIBLE (50 TURNS)**

On Emergency Crank Access Cover:

**LANDING GEAR
EMERGENCY CRANK**

**PULL OUT
LIFT UP**

On Control Console:

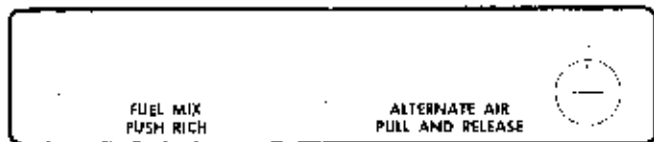
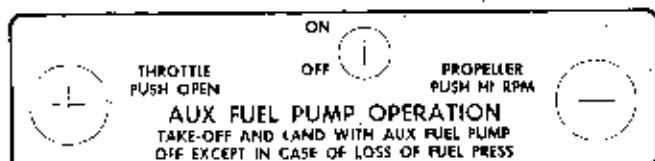

**Temporary Change
to the
Pilot's Operating Handbook
and
FAA Approved Airplane Flight Manual**

P/N 33-590009-13TC1

Publication Affected	F33A & F33C Pilot's Operating Handbook and FAA Approved Airplane Flight Manual (P/N 33-590009-13, Issued October, 1976 or Subsequent)
Airplane Serial Numbers Affected	CE-674 and After; CJ-129 and After
Description of Change	The addition of a placard to the fuel selector to warn of the no-flow condition that exists between the fuel selector detents.
Filing Instructions	Insert this temporary change into the F33A & F33C Pilot's Operating Handbook and FAA Approved Airplane Flight Manual immediately following page 2-20B (Section II, LIMITATIONS) and retain until rescinded or replaced.

LIMITATIONS**PLACARDS**

Located On The Face Of The Fuel Selector Valve, For Those
Airplanes In Compliance With S.B. 2670:

**WARNING - POSITION SELECTOR IN DETENTS ONLY - NO
FUEL FLOW TO ENGINE BETWEEN DETENTS**

Approved:



A.C. Jackson
Raytheon Aircraft Company
DOA CE-2

On Fuel Selector Panel:

Standard 44-Gallon System (CE-674 thru CE-883) (CJ-129 thru CJ-155)

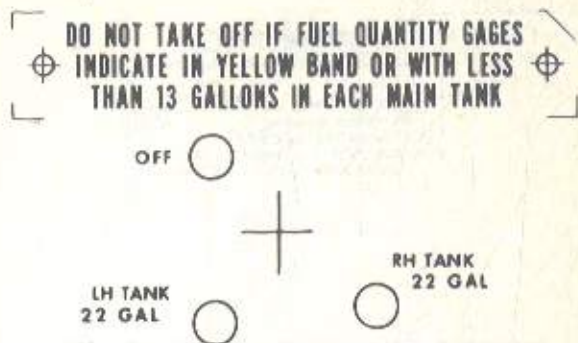

Standard 74-Gallon System (CE-884 and after) (CJ-156 and after)

Optional 74-Gallon System (CE-674 thru CE-883) (CJ-129 thru CJ-155)

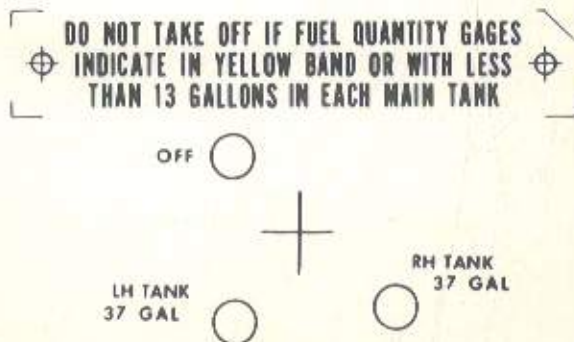

Section II
Limitations

BEECHCRAFT Bonanza F33A
CE-674 and after

*On Left Side Panel Below Instrument Subpanel When
Emergency Static Air System is Installed:*

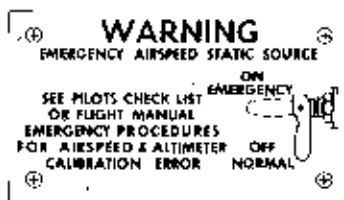

*On Instrument Panel When Anti-collision Light is Not
Installed:*

**THIS AIRCRAFT NOT FULLY
EQUIPPED FOR NIGHT FLIGHT**

*Below Controls on Control Console:
(Unless 100-amp Alternator is Installed)*



On Oxygen Console (optional):

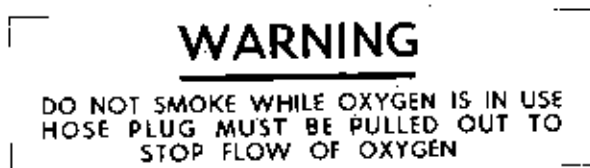

Adjacent to Oxygen Outlet when 5th Seat is Installed:



Section II
Limitations

BEECHCRAFT Bonanza F33A
CE-674 and after

On Each Oxygen Mask Stowage Container:

OXYGEN MASK

*On Each Passenger Outlet (Prior to CE-929, Except CE-919, CE-923, CE-925, and CE-927; Prior to CJ-156) and
On All Pilot and Copilot Outlets (All Serials):*



*On Oxygen Manifold (Serials CE-919, CE-923, CE-925,
CE-927, CE-929 and after; CJ-156 and after):*

OXYGEN - NO SMOKING WHILE IN USE
PULL PLUG TO STOP FLOW

OXYGEN - NO SMOKING WHILE IN USE
PULL PLUG TO STOP FLOW

Below Left and Right Middle Windows after compliance with BEECHCRAFT Service Instructions 1241:

(Serials CE-674 thru CE-928, except CE-919, CE-923, CE-925, and CE-927; CJ-129 thru CJ-155):

**EMERGENCY EXIT
LIFT LATCH - PULL PIN
PUSH WINDOW OUT**

On the Face of Emergency Exit Latch Cover (Serials CE-919, CE-923, CE-925, CE-927, CE-929 and after; CJ-156 and after):

**EMERGENCY EXIT
PULL COVER
ROTATE HANDLE UP
BREAKING SAFETY WIRE
PUSH WINDOW OUT**

Section II
Limitations

BEECHCRAFT Bonanza F33A
CE-674 and after

On Handle of Emergency Exit Handle (Serials CE-919, CE-923, CE-925, CE-927, CE-929 and after; CJ-156 and after):

**ROTATE HANDLE UP
BREAKING SAFETY
WIRE
PUSH WINDOW OUT**

On Inside of Cabin Door Adjacent to Door Handle (Serials CE-1301, CE-1307 and after; CJ-180 and after):

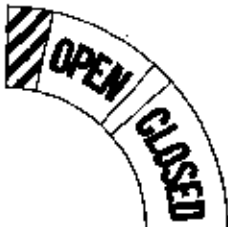

On Middle Windows (openable):

**DO NOT OPEN
IN FLIGHT**

**LATCH WINDOW
BEFORE TAKE-OFF**

Above Inside Door Handle:

**ROTATE HANDLE TO
FULL LOCKED POSITION**



On Hat Shelf:

**HAT SHELF
NO HEAVY OBJECTS**

On Inside of Baggage Compartment Door:

**BAGGAGE COMPARTMENT AND/OR FIFTH SEAT
LOAD IN ACCORDANCE WITH
AIRCRAFT FLIGHT MANUAL
MAXIMUM STRUCTURAL CAPACITY - 270 POUNDS**

On Windows Adjacent To Pilot's And Copilot's Seats:

SHOULDER HARNESS
MUST BE WORN AT
ALL TIMES WHILE AT
PILOT POSITIONS

On Windows, Adjacent To 3rd, 4th & 5th Seats:

SHOULDER HARNESS
MUST BE WORN DURING
TAKE-OFF AND LANDING
WITH SEAT BACK UPRIGHT

On Inboard Side Of Seat Back For 3rd & 4th Seats:



SECTION III EMERGENCY PROCEDURES

TABLE OF CONTENTS

<i>SUBJECT</i>	<i>PAGE</i>
Emergency Airspeeds	3-3
Engine Failure	
During Take-off Ground Roll	3-4
After Liftoff and In Flight	3-4
Engine Discrepancy Checks	
Rough Running Engine	3-5
Loss of Engine Power	3-5
Airstart Procedure	3-5
Engine Fire	
In Flight	3-6
On The Ground	3-6
Emergency Descent	3-6
Maximum Glide Configuration	3-7
Landing Emergencies	
Landing Without Power	3-7
Landing Gear Retracted — With Power	3-8
Systems Emergencies	
Propeller Overspeed	3-8
Starter Energized Warning Light	
Illuminated	3-8A
Alternator Out Procedure	3-8A
Unscheduled Electric Elevator Trim	3-9
Landing Gear Manual Extension	3-10
Landing Gear Retraction After	
Practice Manual Extension	3-11

**Section III
Emergency Procedures**

**BEECHCRAFT Bonanza F33A
CE-674 and after**

<i>SUBJECT</i>	<i>PAGE</i>
Induction System Icing.....	3-11
Emergency Static Air Source System.....	3-11
Emergency Exits.....	3-12
Unlatched Door In Flight.....	3-13
Spins.....	3-13
Emergency Speed Reduction.....	3-14

All airspeeds quoted in this section are indicated airspeeds (IAS).

EMERGENCY AIRSPEEDS (3400 LBS)

Emergency Descent 154 KTS

Maximum Glide Range 105 KTS

Emergency Landing Approach 83 KTS

The following information is presented to enable the pilot to form, in advance, a definite plan of action for coping with the most probable emergency situations which could occur in the operation of the airplane. Where practicable, the emergencies requiring immediate corrective action are treated in check list form for easy reference and familiarization. Other situations, in which more time is usually permitted to decide on and execute a plan of action, are discussed at some length.

ENGINE FAILURE

DURING TAKE-OFF GROUND ROLL

1. Throttle - CLOSED
2. Braking - MAXIMUM
3. Fuel Selector Valve - OFF
4. Battery and Alternator Switches - OFF

AFTER LIFTOFF AND IN FLIGHT

Landing straight ahead is usually advisable. If sufficient altitude is available for maneuvering, accomplish the following:

1. Fuel Selector Valve - SELECT OTHER TANK (feel for detent)
2. Auxiliary Fuel Pump - ON
3. Mixture - FULL RICH, then LEAN AS REQUIRED
4. Magnetos - CHECK LEFT RIGHT, then BOTH ON

NOTE

The most probable cause of engine failure would be loss of fuel flow or improper functioning of the ignition system.

If No Restart:

1. Select most favorable landing site.
2. The use of landing gear is dependent on the terrain where landing must be made.

ENGINE DISCREPANCY CHECKS

CONDITION: ROUGH RUNNING ENGINE

1. Mixture - FULL RICH, then LEAN as required
2. Magneto/Start Switch - "BOTH" position (check to verify)

CONDITION: LOSS OF ENGINE POWER

1. Fuel Flow Gage - CHECK

If fuel flow is abnormally low:

- a. Mixture - FULL RICH
 - b. Auxiliary Fuel Pump - ON (then OFF if performance does not improve in a few moments)
2. Fuel Quantity Indicator - CHECK for fuel supply in tank being used

If tank being used is empty:

Fuel Tank Selector Valve - SELECT OTHER FUEL TANK
(feel for detent)

AIR START PROCEDURE

1. Fuel Selector Valve - SELECT TANK MORE NEARLY FULL (feel for detent)
2. Throttle - RETARD
3. Mixture Control - FULL RICH
4. Auxiliary Fuel Pump - ON until power is regained, then OFF (Leave On if Engine Driven Fuel Pump is inoperative.)
5. Throttle - ADVANCE to desired power
6. Mixture - LEAN as required

ENGINE FIRE

IN FLIGHT

The red FIREWALL AIR control on the outboard side of the left lower subpanel should be pulled to close off all heating system outlets so that smoke and fumes will not enter the cabin. In the event of engine fire, shut down the engine as follows and make a landing:

1. Firewall Air Control - PULL TO CLOSE
2. Mixture - IDLE CUT-OFF
3. Fuel Selector Valve - OFF
4. Battery, Alternator, and Magneto/Start Switches - OFF
(Extending the landing gear can be accomplished manually if desired.)
5. Do not attempt to restart engine.

ON THE GROUND

1. Mixture - IDLE CUT-OFF
2. Fuel Selector Valve - OFF
3. Battery, Alternator and Magneto/Start Switches - OFF
4. Fire Extinguisher - USE TO EXTINGUISH FIRE

EMERGENCY DESCENT

1. Power - IDLE
2. Propeller - HIGH RPM
3. Landing Gear - DOWN
4. Airspeed - ESTABLISH 154 KTS

MAXIMUM GLIDE CONFIGURATION

1. Landing Gear - UP

NOTE

On S/N CE-1301, CE-1307 and after, and CJ-180 and after, the landing gear will not retract unless the throttle is in a position corresponding to approximately 17 in. Hg manifold pressure or above.

2. Flaps - UP
3. Cowl Flaps - CLOSED
4. Propeller - PULL for LOW RPM
5. Airspeed - 105 KTS

Glide distance is approximately 1.7 nautical miles (2 statute miles) per 1000 feet of altitude above the terrain.

LANDING EMERGENCIES

LANDING WITHOUT POWER

When assured of reaching the landing site selected, and on final approach:

1. Airspeed - ESTABLISH 78 TO 83 KTS
2. Fuel Selector Valve - OFF
3. Mixture - IDLE CUT-OFF
4. Magneto/Start Switch - OFF
5. Flaps - AS REQUIRED
6. Landing Gear - DOWN or UP (depending on terrain)

NOTE

On S/N CE-1301, CE-1307 and after, and CJ-180 and after, the landing gear will not retract unless the throttle is in a position corresponding to approximately 17 in. Hg manifold pressure or above.

7. Battery and Alternator Switches - OFF

LANDING GEAR RETRACTED - WITH POWER

If possible, choose firm sod or foamed runway. Make a normal approach, using flaps as necessary. When sure of reaching the selected landing spot:

NOTE

On S/N CE-1301, CE-1307 and after, and CJ-180 and after, the landing gear will not retract unless the throttle is in a position corresponding to approximately 17 in. Hg manifold pressure or above.

1. Throttle - CLOSED
2. Mixture - IDLE CUT-OFF
3. Battery, Alternator and Magneto/Start Switches - OFF
4. Fuel Selector Valve - OFF
5. Keep wings level during touchdown.
6. Get clear of airplane as soon as possible after it stops.

SYSTEMS EMERGENCIES

PROPELLER OVERSPEED

1. Throttle - RETARD TO RED LINE

NOTE

On S/N CE-1301, CE-1307 and after, and CJ-180 and after, the landing gear will not retract unless the throttle is in a position corresponding to approximately 17 in. Hg manifold pressure or above.

2. Airspeed - REDUCE
3. Oil Pressure - CHECK

WARNING

If loss of oil pressure was the cause of over-speed, the engine will seize after a short period of operation.

4. Land - SELECT NEAREST SUITABLE SITE and follow LANDING EMERGENCIES procedure.

STARTER ENERGIZED WARNING LIGHT ILLUMINATED (If installed)

After engine start, should the starter relay remain engaged, the starter will remain energized and the starter energized warning light will remain illuminated. Continuing to supply power to the starter will result in eventual loss of electrical power.

On the Ground:

1. Battery and alternator switches - OFF.
2. Do not take off.

In Flight After Air Start:

1. Battery and alternator switches - OFF.
2. Land as soon as practical.

ALTERNATOR-OUT PROCEDURE

An inoperative alternator will place the entire electrical operation of the airplane except engine ignition on the battery. An alternator failure will be indicated by

illumination of the warning light, located on the instrument panel below the flight instruments.

The warning light will not illuminate until the alternator output is almost zero. A verification of alternator malfunction would be a discharge shown on the ammeter. There is no indication of overvoltage except that the warning light will illuminate as though the alternator is out.

Alternator Warning Light Illuminated:

1. Verify alternator out with ammeter - will show discharge.

NOTE

If the ammeter does not show a discharge, a malfunction in the warning light system is indicated, and the alternator switch should be left ON.

2. If ammeter shows a discharge, Alternator Switch - OFF MOMENTARILY, THEN ON (this resets the overvoltage relay)

If the warning light does not illuminate, continue to use the alternator.

3. If the warning light illuminates, Alternator Switch - OFF
4. Nonessential Electrical Equipment - OFF to conserve battery power.

UNSCHEDULED ELECTRIC ELEVATOR TRIM

1. Airplane Attitude - MAINTAIN using elevator control
2. Elevator Trim Thumb Switch (On Control Wheel) - MOVE IN DIRECTION OPPOSITE UNSCHEDULED PITCH TRIM to open circuit breaker
3. Elevator Trim ON-OFF Switch (On Instrument Panel) - OFF
4. Manual Elevator Trim Control Wheel - RETRIM AS DESIRED

NOTE

Do not attempt to operate the electric trim system until the cause of the malfunction has been determined and corrected.

LANDING GEAR MANUAL EXTENSION

Manual extension of the landing gear can be facilitated by first reducing airspeed. Then proceed as follows:

1. LDG GR MOTOR Circuit Breaker (Right Subpanel) - OFF (pull out)
2. Landing Gear Switch Handle - DOWN position
3. Handcrank Handle Cover (at rear of front seats) - REMOVE
4. Handcrank - ENGAGE and TURN COUNTERCLOCKWISE AS FAR AS POSSIBLE (approximately 50 turns)

CAUTION

The manual extension system is designed to lower the landing gear only. DO NOT ATTEMPT TO RETRACT THE GEAR MANUALLY.

5. If electrical system is operative, check landing gear position lights and warning horn (check LDG GR RELAY circuit breaker engaged).
6. Handcrank - DISENGAGE. Always keep it stowed when not in use.

WARNING

Do not operate the landing gear electrically with the handcrank engaged, as damage to the mechanism could occur.

After emergency landing gear extension, do not move any landing gear controls or reset any switches or circuit breakers until airplane is on jacks, as failure may have been in the gear-up circuit and gear might retract.

LANDING GEAR RETRACTION AFTER PRACTICE MANUAL EXTENSION

After practice manual extension of the landing gear, the gear can only be retracted electrically, as follows:

1. Handcrank - CHECK, STOWED
2. Landing Gear Motor Circuit Breaker - IN
3. Landing Gear Switch Handle - UP

NOTE

On S/N CE-1301, CE-1307 and after, and CJ-180 and after, the landing gear will not retract unless the throttle is in a position corresponding to approximately 17 in. Hg manifold pressure or above.

INDUCTION SYSTEM ICING

If the induction system alternate air source door becomes frozen in the closed position, the Alternate Air Pull and Release Control T-handle should be pulled and released to force the door open.

EMERGENCY STATIC AIR SOURCE SYSTEM

THE EMERGENCY STATIC AIR SOURCE SHOULD BE USED FOR CONDITIONS WHERE THE NORMAL STATIC SOURCE HAS BEEN OBSTRUCTED. When the airplane has been exposed to moisture and/or icing conditions (especially on the ground), the possibility of obstructed static ports should be considered. Partial obstruction will result in the rate of climb indication being sluggish during a climb or descent. Verification of suspected obstruction is possible by switching to the emergency system and noting a sudden sustained change in rate of climb. This may be accompanied by abnormal indicated airspeed and altitude changes beyond normal calibration differences.

Whenever any obstruction exists in the Normal Static Air System or the Emergency Static Air System is desired for use:

1. Pilot's Emergency Static Air Source - Switch to ON EMERGENCY.
2. For Airspeed Calibration and Altimeter Correction, refer to PERFORMANCE Section.

NOTE

The Emergency Static Air valve should be in the NORMAL position when the system is not needed.

EMERGENCY EXITS

Emergency exits, provided by the openable window on each side of the cabin, may be used for egress in addition to the cabin door and the optional cargo door.

NOTE

For access past the 3rd and/or 4th seats, rotate the red handle, located on the lower inboard side of the seat back, and fold the seat back over.

To Open Each Emergency Exit:

Serials CE-674 thru CE-928, Except CE-919, CE-923, CE-925 and CE-927; CJ-129 thru CJ-155:

An emergency exit placard is installed below the left and right openable windows.

1. Lift the latch.
2. Pull out the emergency release pin and push the window out.

Serials CE-919, CE-923, CE-925, CE-927, CE-929 and after; CJ-156 and after:

1. Remove cover as indicated by placard in the center of the Ventilation/Emergency Exit latch.
2. Rotate handle up as indicated by placard, breaking safety wire, and push window out.

NOTE

Anytime the window has been opened by breaking the safety wire on the red emergency latch, the window must be reattached and wired by a qualified mechanic using QQ-W-343, Type S, .020 diameter copper wire prior to further airplane operation.

UNLATCHED DOOR IN FLIGHT

If the cabin door is not locked it may unlatch in flight. This may occur during or just after takeoff. The door will trail open approximately 3 inches but the flight characteristics of the airplane will not be affected, except that rate of climb will be reduced. Return to the field in a normal manner. If practicable, during the landing flare-out have a passenger hold the door to prevent it swinging open.

SPINS

Spins are prohibited. If a spin is entered inadvertently:

Immediately move the control column full forward and simultaneously apply full rudder opposite to the direction of the spin; continue to hold this control position until rotation stops and then neutralize all controls and execute a smooth pullout. Ailerons should be neutral and throttle in idle position at all times during recovery.

EMERGENCY SPEED REDUCTION

In an emergency, the landing gear may be used to create additional drag. Should disorientation occur under instrument conditions, the lowering of the landing gear will reduce the tendency for excessive speed buildup. This procedure would also be appropriate for a non-instrument rated pilot who unavoidably encounters instrument conditions or in other emergencies such as severe turbulence.

Should the landing gear be used at speeds higher than the maximum extension speed, a special inspection of the gear doors in accordance with maintenance manual procedures is required, with repair as necessary.

SECTION IV NORMAL PROCEDURES

TABLE OF CONTENTS

<i>SUBJECT</i>	<i>PAGE</i>
Airspeeds For Safe Operation	4-3
Preflight Inspection	4-4
Before Starting	4-6
External Power	4-7
Starting Engine Using Auxiliary Power Unit	4-8
Starting	4-8
After Starting, And Taxi	4-9
Before Takeoff	4-10
Takeoff	4-11
Climb	4-11
Cruise	4-12
Leaning Using The Exhaust Gas Temperature Indicator (EGT)	4-12
Descent	4-12
Before Landing	4-13
Balked Landing	4-13
After Landing	4-13
Shutdown	4-14
Environmental Systems	
Oxygen System	4-14
Heating And Ventilation	4-17
Cold Weather Operation	
Preflight Inspection	4-17
Engine	4-18
Icing Conditions	4-19
Noise Characteristics	4-19

All airspeeds quoted in this section are indicated airspeeds (IAS).

AIRSPEEDS FOR SAFE OPERATION (3400 LBS)

Maximum Demonstrated
Crosswind Component 17 KTS

Takeoff:

Lift-off 71 KTS

50-ft Speed 77 KTS

Best Angle-of-Climb (V_x) 77 KTS

Best Rate-of-Climb (V_y) 96 KTS

Cruise Climb 107 KTS

Turbulent Air Penetration 134 KTS

Landing Approach (Flaps Down) 70 KTS

Balked Landing Climb 70 KTS

Gross
WT.

PREFLIGHT INSPECTION

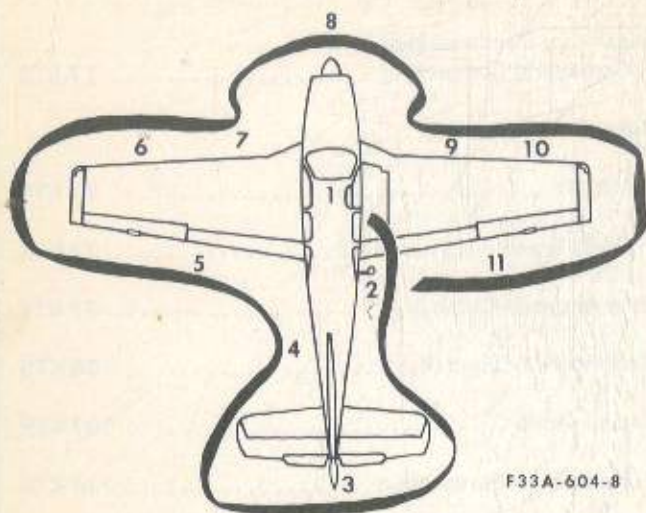

F33A-604-8

1. CABIN:

- a. Parking Brake - SET
- b. Control Lock - REMOVE
- c. All Switches - OFF

2. RIGHT FUSELAGE:

- a. Baggage Compartment Door - SECURE
- b. Static Pressure Button - UNOBSTRUCTED
- c. Emergency Locator Transmitter - ARMED

3. EMPENNAGE:
 - a. Control Surfaces - CHECK
 - b. Tie Down - REMOVE
 - c. Position Light - CHECK
 - d. Cabin Air Intake - CHECK

4. LEFT FUSELAGE:
 - a. Static Pressure Button - UNOBSTRUCTED
 - b. All Antennas - CHECK

5. LEFT WING TRAILING EDGE:
 - a. Flap - CHECK
 - b. Aileron - CHECK
 - c. Wing Tip - CHECK
 - d. Position Light - CHECK

6. LEFT WING LEADING EDGE:
 - a. Stall Warning - CHECK
 - b. Pitot Tube - CHECK; Cover - REMOVE
 - c. Fuel Tank - CHECK QUANTITY; Filler Cap - SECURE
 - d. Cabin Air Intake - CHECK
 - e. Tie Down and Chocks - REMOVE

7. LEFT LANDING GEAR:
 - a. Wheel Well Door, Tire and Strut - CHECK
 - b. Fuel Vent - CHECK
 - c. Fuel Sump - DRAIN
 - d. Fuel Selector Valve Sump - DRAIN; Cover - SECURE

Section IV
Normal Procedures

BEECHCRAFT Bonanza F33A
CE-674 and after

8. NOSE SECTION:
 - a. Left Cowl Flap - CHECK
 - b. Engine Oil - CHECK; Cap - SECURE
 - c. Left Cowl - SECURE
 - d. Propeller - CHECK
 - e. Wheel Well Doors, Tire and Strut - CHECK
 - f. Landing and Taxi Lights - CHECK
 - g. Induction Air Intake - CLEAR
 - h. Engine - CHECK GENERAL CONDITION
 - i. Right Cowl - SECURE
 - j. Right Cowl Flap - CHECK
 - k. Chocks - REMOVE

9. RIGHT LANDING GEAR:
 - a. Fuel Vent - CHECK
 - b. Fuel Sump - DRAIN
 - c. Wheel Well Door, Tire and Strut - CHECK

10. RIGHT WING LEADING EDGE:
 - a. Cabin Air Intake - CHECK
 - b. Tie Down and Chocks - REMOVE
 - c. Fuel Tank - CHECK QUANTITY; Filler Cap SECURE

11. RIGHT WING TRAILING EDGE:
 - a. Position Light - CHECK
 - b. Wing Tip - CHECK
 - c. Aileron - CHECK
 - d. Flap - CHECK

BEFORE STARTING

1. Seats - POSITION AND LOCK; Seat Backs - UPRIGHT
2. Seat Belts and Shoulder Harnesses - FASTEN
3. Parking Brake - SET
4. All Avionics - OFF
5. Circuit Breakers - IN

6. Landing Gear Handle - DOWN
7. Flaps - UP
8. Cowl Flaps - OPEN
9. Light Switches - OFF
10. Electric Elevator Trim Switch - OFF
11. Fuel Selector Valve - CHECK OPERATION THEN
SELECT TANK MORE NEARLY FULL
12. Battery and Alternator Switches - ON (If external power
is used, turn Alternator Switch - OFF)
13. Fuel Quantity Indicators - CHECK QUANTITY

WARNING

Do not take off if gages indicate in yellow arc or
with less than 13 gallons in each tank.

EXTERNAL POWER

The following precautions shall be observed while using
external power:

CAUTION

Never use external power without a battery
installed in the system.

1. The Battery Switch shall be ON and all avionics and
electrical switches OFF. This protects the voltage reg-
ulators and associated electrical equipment from vol-
tage transients (power fluctuations).
2. The airplane has a negative ground system. Connect the
positive and negative leads of the external power unit to
the corresponding positive and negative terminals of the
airplane's external power receptacle.
3. In order to prevent arcing, no power shall be supplied
while the connection is being made.

STARTING ENGINE USING AUXILIARY POWER UNIT

1. Alternator, and Avionics Equipment - OFF
2. Battery Switch - ON
3. Auxiliary Power Unit - CONNECT
4. Auxiliary Power Unit - (28-volt system - SET OUTPUT 27.0 to 28.5 volts)
(14-volt system - SET OUTPUT 13.5 to 14.25 volts)
5. Auxiliary Power Unit - ON
6. Engine START using normal procedures
7. Auxiliary Power Unit - OFF (after engine has been started)
8. Auxiliary Power Unit - DISCONNECT
9. Alternator Switch - ON

STARTING

CAUTION

Vernier-type engine controls should not be rotated clockwise after being advanced to the full forward position.

1. Mixture - FULL RICH
2. Propeller - HIGH RPM
3. Throttle - FULL OPEN

NOTE

If the engine is hot, and the ambient temperature is 90°F or above, place mixture control in IDLE CUT-OFF, switch aux fuel pump to ON for 30 to 60 seconds, then OFF. Return mixture control to FULL RICH.

4. Auxiliary Fuel Pump - ON until fuel flow peaks then OFF
5. Throttle - OPEN ¼ inch APPROXIMATELY
6. Magneto/Start Switch - START position; release to BOTH position when engine fires.

CAUTION

Do not engage starter for more than 30-seconds in any 4-minute time period.

7. In Event of Overprime Condition:
 - a. Mixture - IDLE CUT-OFF
 - b. Throttle - OPEN
 - c. Magneto/Start Switch - START position
 - d. As engine fires, reduce throttle to IDLE and advance the mixture control to FULL RICH.

NOTE

During hot starts, turn the Auxiliary Fuel Pump ON momentarily after starting to purge the system, then turn OFF.

8. Throttle - 1000 to 1200 RPM
9. Oil Pressure - CHECK
10. External Power (if used) - DISCONNECT
11. Alternator Switch - ON; CHECK FOR CHARGING
12. All Engine Indicators - CHECK
13. Starter Energized Warning Light (if installed) - CHECK; should be illuminated during start and extinguished after start.

CAUTION

If starter energized warning light is inoperative or is not installed, the ammeter indication should be less than 25% of full charge at 1000 to 1200 rpm within two minutes, with no additional equipment on. If not, turn off the battery and alternator switches and do not take off.

AFTER STARTING, AND TAXI

CAUTION

Never taxi with a flat shock strut.

1. Brakes - RELEASE AND CHECK
2. Avionics Equipment - ON, AS REQUIRED
3. Lights - AS REQUIRED

CAUTION

Do not operate engine above 1200 RPM until oil temperature reaches 24°C.

BEFORE TAKEOFF

1. Seat Belts and Shoulder Harnesses - CHECK
2. Parking Brake - SET
3. Radios - CHECK
4. Engine Instruments - CHECK
5. Flight Instruments - CHECK AND SET

NOTE

To ensure adequate gyro pressure when operating two air-driven gyros during ground operation and/or holding prior to takeoff, maintain an engine speed of 700-800 rpm in order to hold a value of 4.3 in. Hg on the instrument pressure gage. With a requirement of three or more air-driven gyros, maintain an engine speed of 1200 rpm.

6. Starter Energized Warning Light (if installed) - CHECK (should not be lit). If light is not installed or is inoperative, check ammeter for stabilized indication between 0 and 25% of full charge at 1000 to 1200 rpm.
7. Throttle - 1700 RPM
8. Propeller - EXERCISE to obtain 300 to 400 rpm drop, then return to high rpm
9. Magnetos - CHECK at 1700 rpm on each magneto (variance between individual magnetos should not exceed 50 rpm; maximum drop should not exceed 150 rpm.)
10. Trim - SET
 - a. Aileron - NEUTRAL
 - b. Elevator - 0° (3° nose up if only front seats are occupied)

11. Flaps - UP
12. Doors and Windows - SECURE (serials CE-1301, CE-1307 and after; CJ-180 and after - check cabin door lock indicator - CLOSED)
13. Flight Controls - CHECK PROPER DIRECTION AND FREEDOM OF MOVEMENT
14. Mixture - FULL RICH or as required by field elevation
15. Brakes - RELEASED
16. Instruments - CHECK (Make final check of manifold pressure, fuel flow, and rpm at the start of take-off run.)

TAKEOFF

Take-off Power Full Throttle, 2700 RPM

1. Power - SET TAKE-OFF POWER (Mixture - SET as required by field elevation)
2. Brakes - RELEASE, THEN ACCELERATE to recommended speed
3. Landing Gear - RETRACT when positive rate of climb is established
4. Airspeed - ESTABLISH DESIRED CLIMB SPEED when clear of obstacles

CLIMB

Maximum Continuous Power

(Serials CE-674 thru CE-890 with 2- or 3-Blade Propeller Installed, and CE-891 and after with McCauley 3-Blade Propeller Installed)

(Serials CJ-129 thru CJ-155) Full Throttle, 2700 rpm

Maximum Normal Operating Power

(Serials CE-891 and after with 2-Blade Propeller Installed)

(Serials CJ-156 and after) Full Throttle, 2550 rpm

Cruise Climb Power 25 in. Hg at 2500 rpm

1. Engine Temperatures - MONITOR
2. Power - SET
3. Mixture - SET FUEL FLOW

CRUISE

See Cruise Charts in PERFORMANCE Section

1. Cowl Flaps - CLOSED
2. Power - SET
3. Mixture - SET FUEL FLOW

LEANING USING THE EXHAUST GAS TEMPERATURE INDICATOR (EGT)

A thermocouple-type exhaust gas temperature (EGT) probe is mounted in the right side of the exhaust system. This probe is connected to an indicator on the right side of the instrument panel. The indicator is calibrated in degrees Fahrenheit. Use EGT system to lean the fuel/air mixture when cruising at 75% power or less in the following manner:

1. Lean the mixture and note the point on the indicator that the temperature peaks and starts to fall.
 - a. CRUISE (LEAN) MIXTURE - Increase the mixture until the EGT shows a drop of 25°F below peak on the rich side of peak.
 - b. BEST POWER MIXTURE - Increase the mixture until the EGT shows a drop of 100°F below peak on the rich side of peak.

CAUTION

Do not continue to lean mixture beyond that necessary to establish peak temperature.

2. Continuous operation is recommended at 25°F or more below peak EGT only on the rich side of peak.
3. Changes in altitude and power settings require the peak EGT to be rechecked and the mixture reset.

DESCENT

1. Altimeter - SET
2. Cowl Flaps - CLOSED

3. Power - AS REQUIRED (avoid prolonged idle settings and low cylinder head temperatures)
4. Mixture - ENRICH AS REQUIRED

BEFORE LANDING

1. Seat Belts and Shoulder Harnesses - FASTENED; Seat Backs - UPRIGHT
2. Fuel Selector Valve - SELECT TANK MORE NEARLY FULL
3. Cowl Flaps - AS REQUIRED
4. Mixture - FULL RICH or as required by field elevation
5. Landing Gear - DOWN AND CHECK (Observe maximum extension speed)
6. Landing and Taxi Lights - AS REQUIRED
7. Flaps - DOWN (Observe maximum extension speed)
8. Airspeed - ESTABLISH NORMAL LANDING APPROACH SPEED
9. Propeller - HIGH RPM

BALKED LANDING

1. Power - FULL THROTTLE, 2700 RPM
2. Airspeed - 70 KTS until clear of obstacles, then trim to normal climb speed
3. Flaps - UP
4. Landing Gear - UP
5. Cowl Flaps - OPEN

AFTER LANDING

1. Landing and Taxi Lights - AS REQUIRED
2. Flaps - UP
3. Trim Tab - SET TO 0°
4. Cowl Flaps - OPEN

SHUTDOWN

1. Brakes - SET
2. Electrical and Radio Equipment - OFF
3. Throttle - CLOSE
4. Mixture - IDLE CUT-OFF
5. Magneto/Start Switch - OFF after engine stops
6. Battery and Alternator Switches - OFF
7. Control Lock - INSTALL if conditions warrant
8. Wheel Chocks - INSTALL; Parking Brake - RELEASE

ENVIRONMENTAL SYSTEMS

OXYGEN SYSTEM

PREFLIGHT

1. Check Oxygen Pressure Gage for pressure reading.
2. Determine percent of full system.
3. Multiply oxygen duration in minutes by percent of full bottle.

EXAMPLE:

People.....	5
Gage Pressure.....	1500 psig
Percent Capacity (from chart).....	80%
Cylinder Capacity (full).....	49 cu ft
Altitude (planned flight).....	15,000 ft
Duration (90% full).....	149 min
Duration (80% full).....	119 min

OXYGEN AVAILABLE WITH PARTIALLY FULL BOTTLE

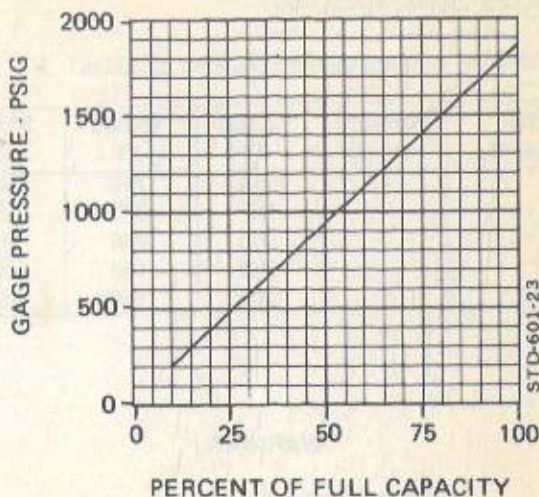

OXYGEN DURATION

The recommended masks are provided with the system. They are designed to be adjustable to fit the average person, with minimum leakage of oxygen.

CAUTION

Since 90% of the system efficiency is determined by the fit of the oxygen mask, make certain the masks fit properly and are in good condition.

The following data compiled on the basis of 90% of bottle capacity.

OXYGEN DURATION CHART

Duration in minutes at the following altitudes:

Bottle Capacity	Persons Using	12,500 FT	15,000 FT	20,000 FT
49 cu ft	1	1014	746	507
	2	507	373	253
	3	338	248	169
	4	253	186	126
	5	202	149	101

WARNING

NO SMOKING when using oxygen.

IN FLIGHT

The use of oxygen is recommended to be in accordance with current FAR operating rules.

1. Oxygen Control Valve - OPEN SLOWLY
2. Mask - INSERT FITTING, DON MASK (adjust mask for proper fit)
3. Oxygen - CHECK INDICATOR FOR FLOW

AFTER USING

1. Discontinue use by unplugging mask from outlet.

NOTE

Closing the control valve while in flight is not necessary due to automatic sealing of the outlet when the mask is unplugged. However, it is desirable to shut off supply when not in use.

2. Oxygen Control Valve - CLOSED (may be accomplished during shut-down)

HEATING AND VENTILATION

Refer to the SYSTEMS DESCRIPTION Section for operation of heating and ventilation controls.

COLD WEATHER OPERATION

PRE-FLIGHT INSPECTION

All accumulations of ice, snow and frost must be removed from the wings, tail, control surfaces and hinges, propeller, windshield, fuel cell filler caps, crankcase vents, and fuel vents. If such accumulations are not removed completely, the airplane shall not be flown. The deposits will not blow off in flight. While an adverse weight factor is clearly involved in the case of heavy deposits, it is less obvious that even slight accumulations will disturb or completely destroy the designed aerodynamic properties of the airfoils.

The normal preflight procedures should then be completed, with particular attention given to check of flight controls for complete freedom of movement.

ENGINE

Use engine oil in accordance with Consumable Materials in the HANDLING, SERVICING AND MAINTENANCE Section. Always pull the propeller through by hand, opposite the direction of rotation, several times to clear the engine and "limber up" the cold, heavy oil before using the starter. This will also lessen the load on the battery if external power is not used.

Under very cold conditions, it may be necessary to preheat the engine prior to a start. Particular attention should be given to the oil cooler, engine sump and propeller hub to ensure proper preheat. A start with congealed oil in the system may produce an indication of normal pressure immediately after the start, but then the oil pressure may decrease when residual oil in the engine is pumped back with the congealed oil in the sump. If an engine heater capable of heating both the engine sump and cooler is not available, the oil should be drained while the engine is hot and stored in a warm area until the next flight.

If there is no oil pressure within the first 30 seconds of running, or if oil pressure drops after a few minutes of ground operation, shut down and check for broken oil lines, oil cooler leaks or the possibility of congealed oil.

NOTE

It is advisable to use external power for starting in cold weather.

During warm-up, monitor engine temperatures closely, since it is possible to exceed the cylinder head temperature limit in trying to bring up the oil temperature. Exercise the propeller several times to remove cold oil from the pitch change mechanism. The propeller should also be cycled occasion-

ally in flight.

During letdown and landing, give special attention to engine temperatures, since the engine will have a tendency toward overcooling.

ICING CONDITIONS

Flight in known icing conditions is prohibited.

NOISE CHARACTERISTICS

Approach to and departure from an airport should be made so as to avoid prolonged flight at low altitude near noise-sensitive areas. Avoidance of noise-sensitive areas, if practical, is preferable to overflight at relatively low altitudes.

For VFR operations over outdoor assemblies of persons, recreational and park areas, and other noise-sensitive areas, pilots should make every effort to fly not less than 2000 feet above the surface, weather permitting, even though flight at a lower level may be consistent with the provisions of government regulations.

NOTE

The preceding recommended procedures do not apply where they would conflict with Air Traffic Control clearances or instructions, or where, in the pilot's judgement, an altitude of less than 2000 feet is necessary to adequately exercise his duty to see and avoid other airplanes.

**Section IV
Normal Procedures**

**BEECHCRAFT Bonanza F33A
CE-674 and after**

Flyover noise levels established in compliance with FAR 36 are:

Serials CE-891 and after, and CJ-156 and after:

2-Blade Propeller Using MNOP	76.6 dB(A)
3-Blade Propeller	77.3 dB(A)

NOTE

Flyover noise levels given are not applicable for Serials CE-674 thru CE-890 and CJ-129 thru CJ-155.

No determination has been made by the Federal Aviation Administration that the noise level of this airplane is or should be acceptable or unacceptable for operation at, into or out of any airport.

SECTION V PERFORMANCE

TABLE OF CONTENTS

<i>SUBJECT</i>	<i>PAGE</i>
Introduction to Performance and Flight Planning	5-3
Comments Pertinent to the Use of Performance Graphs.....	5-9
Airspeed Calibration - Normal System	5-10
Airspeed Calibration - Emergency System.....	5-11
Altimeter Correction - Normal System.....	5-12
Altimeter Correction - Emergency System	5-13
Fahrenheit to Celsius Temperature Conversion.....	5-14
ISA Conversion.....	5-15
Stall Speeds - Power Idle	5-16
Wind Components	5-17
Take-Off Distance.....	5-18
Climb	
Serials CE-674 thru CE-890 with 2- or 3-blade propeller installed and CE-891 and after with 3-blade propeller installed.....	5-18B
Serials CJ-129 thru CJ-155 with 2- or 3-blade propeller installed and CJ-156 and after with 3-blade propeller installed.....	5-18B
Serials CE-891 and after with 2-blade propeller installed	5-19
Serials CJ-156 and after with 2-blade propeller installed	5-19
July, 1980	5-1

**Section V
Performance**

**BEECHCRAFT Bonanza F33A
CE-674 and after**

<i>SUBJECT</i>	<i>PAGE</i>
Time, Fuel, and Distance to Climb	5-20
Cruise Power Settings	
75% MCP (Or Full Throttle)	5-21
65% MCP (Or Full Throttle)	5-22
55% MCP (Or Full Throttle)	5-23
45% MCP (Or Full Throttle)	5-24
Cruise Speeds	5-25
Manifold Pressure vs RPM	5-26
Fuel Flow vs Brake Horsepower	5-27
Range Profile - 74 Gallons	5-28
Range Profile - 44 Gallons	5-29
Endurance Profile - 74 Gallons	5-30
Endurance Profile - 44 Gallons	5-31
Landing Distance	5-32

INTRODUCTION TO PERFORMANCE AND FLIGHT PLANNING

The graphs and tables in this section present performance information for flight planning at various parameters of weight, power, altitude and temperature. Examples have been presented on all performance graphs. In addition, the calculations for flight time, block speed and fuel required for a proposed flight are detailed below. All examples and calculations utilize the following conditions:

CONDITIONS

At Denver:

Outside Air Temperature.....15°C (59°F)
 Field Elevation.....5330 ft
 Altimeter Setting.....29.60 in. Hg
 Wind.....270° at 10 kts
 Runway 26L length.....10,010 ft

Route of Trip

*DEN-V81-AMA

For VFR Cruise at 11,500 feet

ROUTE SEGMENT	MAGNETIC COURSE	DIST NM	WIND 11500 FEET DIR/KTS	OAT 11500 FEET °C	ALT SETTING IN.HG
DEN-COS	161°	55	010/30	-5	29.60
COS-PUB	153°	40	010/30	-5	29.60
PUB-TBE	134°	74	100/20	0	29.56
TBE-DHT	132°	87	200/20	9	29.56
DHT-AMA	125°	65	200/20	10	29.56

*REFERENCE: Enroute Low Altitude Chart L-6

At Amarillo:

Outside Air Temperature.....	25°C (77°F)
Field Elevation.....	3605 ft
Altimeter Setting.....	29.56 in. Hg
Wind.....	180° at 10 kts
Runway 21 Length.....	13500 ft

To determine pressure altitude at origin and destination airports, add 100 feet to field elevation for each .1 in. Hg below 29.92, and subtract 100 feet from field elevation for each .1 in. Hg above 29.92.

Pressure Altitude at DEN:

$$29.92 - 29.60 = .32 \text{ in. Hg}$$

The pressure altitude at DEN is 320 feet above the field elevation.

$$5330 - 320 = 5650 \text{ ft}$$

Pressure Altitude at AMA:

$$29.92 - 29.56 = .36 \text{ in. Hg}$$

The pressure altitude at AMA is 360 feet above the field elevation.

$$3605 + 360 = 3965 \text{ ft}$$

NOTE

For flight planning, the difference between cruise altitude and cruise pressure altitude has been ignored.

Calculations for flight time, block speed and fuel requirement:

Cruise Climb:

Enter the graph for Time, Fuel, and Distance to climb at 15°C to 5650 ft and to 3400 lbs. Enter -5°C to 11500 ft and to 3400 lbs. Read:

$$\begin{aligned}\text{Time to Climb} &= 21.0 - 8.0 = 13 \text{ min} \\ \text{Fuel Used to Climb} &= 6.3 - 2.7 = 3.6 \text{ gal} \\ \text{Distance Traveled} &= 42 - 15 = 27 \text{ NM}\end{aligned}$$

The cruise power setting is assumed to be at 2500 rpm. Since cruise at 11,500 feet requires full throttle, the manifold pressure and fuel flow should be read from the cruise power setting table for 75 percent maximum continuous power.

The temperatures for cruise are presented for a standard day (ISA); 20°C (36°F) above a standard day (ISA + 20°C); and 20°C (36°F) below a standard day (ISA - 20°C). These should be used for flight planning. The IOAT values are true temperature values which have been adjusted for the compressibility effects. IOAT should be used for setting cruise power while enroute.

Enter the graph for ISA conversion at 11,500 feet and the temperature for the route segment:

DEN-PUB	OAT	=	-5°C
	ISA Condition	=	ISA + 3°C
PUB-TBE	OAT	=	0°C
	ISA Condition	=	ISA + 8°C
TBE-DHT	OAT	=	9°C
	ISA Condition	=	ISA + 17°C
DHT-AMA	OAT	=	10°C
	ISA Condition	=	ISA + 18°C

Section V
Performance

BEECHCRAFT Bonanza F33A
CE-674 and after

Enter the cruise power settings table for 75 percent maximum continuous power (or full throttle) at 11,000 ft, 12,000 ft. ISA and ISA + 20°C.

	TEMPERATURE					
	ISA			ISA + 20°C		
ALTI-TUDE FEET	MAN. PRESS. IN. HG	FUEL FLOW GPH	TAS KNOTS	MAN. PRESS. IN. HG	FUEL FLOW GPH	TAS KNOTS
11000	19.2	13.1	167	19.2	12.6	167
12000	18.3	12.6	165	18.3	12.2	165

Interpolate for 11,500 feet and the temperature for the appropriate route segment. Results of the interpolations are:

ROUTE SEGMENT	MAN. PRESS. IN. HG	FUEL FLOW GPH	TAS KNOTS
DEN-PUB	18.8	12.6	166
PUB-TBE	18.8	12.7	166
TBE-DHT	18.8	12.5	166
DHT-AMA	18.8	12.5	166

NOTE

The above are exact values for the assumed conditions.

Time and fuel used were calculated as follows:

$$\text{Time} = \frac{\text{Distance}}{\text{Ground Speed}}$$

$$\text{Fuel Used} = (\text{Time}) (\text{Fuel Flow})$$

Results are:

ROUTE SEGMENT	DISTANCE NM	EST GROUND SPEED KNOTS	TIME AT CRUISE ALTITUDE HRS: MIN	FUEL USED FOR CRUISE GAL
DEN-COS	*28	195	:09	1.9
COS-PUB	40	192	:13	2.8
PUB-TBE	74	153	:29	6.1
TBE-DHT	87	154	:34	7.1
DHT-AMA	65	156	:25	5.2

*Distance required to climb has been subtracted from segment distance.

TIME - FUEL - DISTANCE

ITEM	TIME HRS: MINS	FUEL GAL	DISTANCE NM
Start, Runup, Taxi and Take- off acceleration	0:00	2.0	0
Climb	0:13	3.6	27
Cruise	1:50	23.1	294
Total	2:03	28.7	321

Total Flight Time: 2 hours, 3 minutes

Block Speed: $321 \text{ NM} \div 2 \text{ hours, 3 min.} = 157 \text{ knots}$

Reserve Fuel (45 minutes at 45 percent maximum continuous power)

Enter the cruise power settings table for 45 percent MCP (or full throttle). The fuel flow for 45 percent MCP is 9.6 gallons per hour.

Reserve fuel = (45 min) (9.6 GPH) = 7.2 gallons

Total Fuel = $28.7 + 7.2 = 35.9$ gallons

The estimated landing weight is determined by subtracting the fuel required for the trip from the ramp weight:

Assumed ramp weight = 3412 lbs

Estimated fuel from DEN to AMA = (28.7 gal) (6 lbs/gal) = 172 lbs

Estimated landing weight = $3412 - 172 = 3240$ lbs

Examples have been provided on the performance graphs. The above conditions have been used throughout. Rate of climb was determined for the initial cruise altitude conditions.

**COMMENTS PERTINENT TO THE USE OF
PERFORMANCE GRAPHS**

1. The example, in addition to presenting an answer for a particular set of conditions, also presents the order in which the graphs should normally be used, i.e., if the first item in the example is OAT, then enter the graph at the known OAT.
2. The reference lines indicate where to begin following guide lines. Always project to the reference line first, then follow the guide lines to the next known item.
3. Indicated airspeeds (IAS) were obtained by using the AIRSPEED CALIBRATION-NORMAL SYSTEM Graph.
4. The associated conditions define the specific conditions from which performance parameters have been determined. They are not intended to be used as instructions; however, performance values determined from charts can only be achieved if specified conditions exist.
5. The full amount of usable fuel is available for all approved flight conditions.

AIRSPEED CALIBRATION - NORMAL SYSTEM

EXAMPLE:

20 KNOTS '91 MPH
DOWN
11.7%
CAS

VOL. INDICATED AIRSPEED ASSUMES ZERO WIND, SEA LEVEL, 15°C

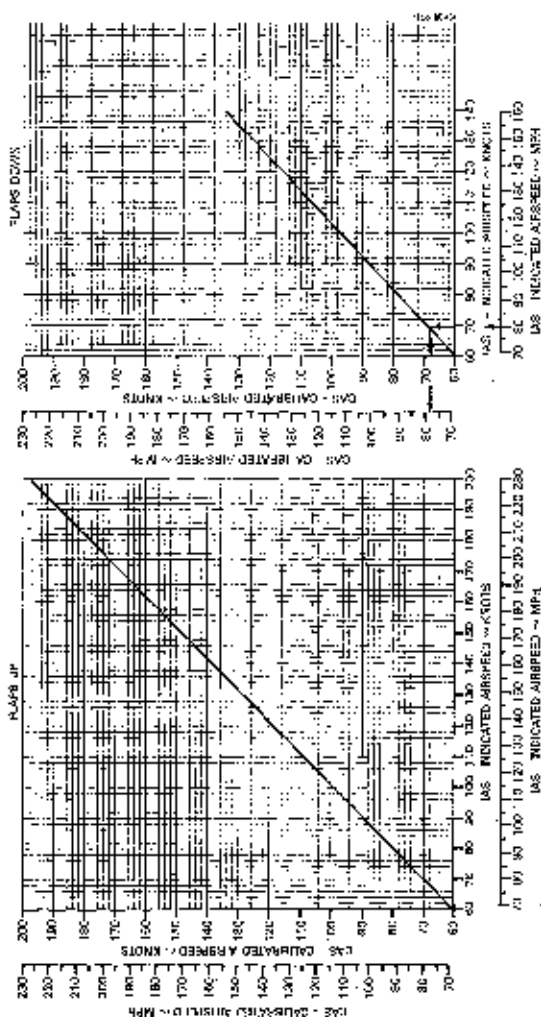

AIRSPEED CALIBRATION - EMERGENCY SYSTEM

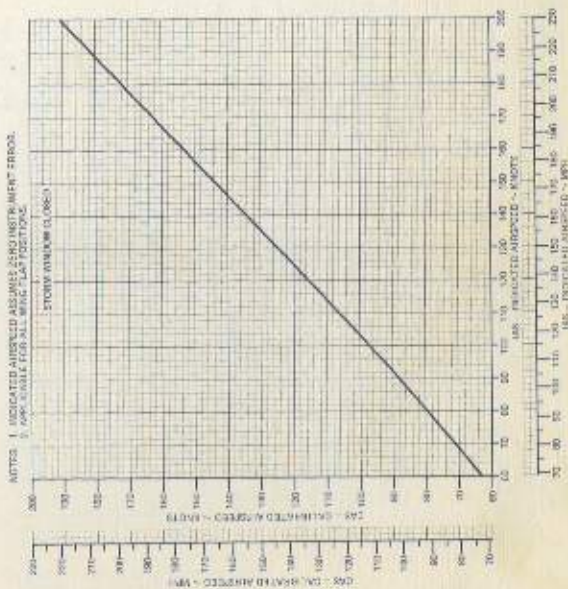
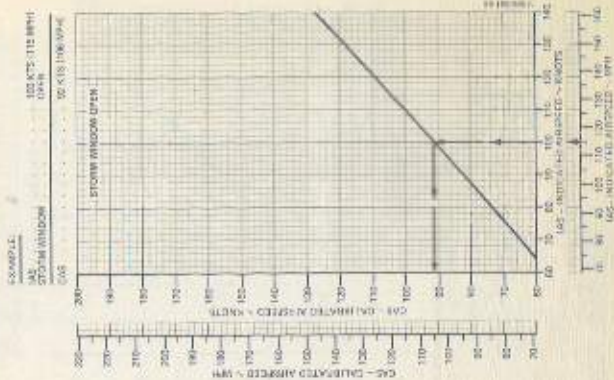

ALTIMETER CORRECTION - NORMAL SYSTEM

NOTE: INDICATED AIRSPEED AND INDICATED ALTITUDE ASSUME
ZERO INSTRUMENT ERROR

EXAMPLE

IAS - 70 KNOTS (80 MPH)
FLAPS - DOWN
INDICATED PRESSURE ALTITUDE - 4500 FT
ALTIMETER CORRECTION - 12 FT
ACTUAL PRESSURE ALTITUDE - 4500 - 12 = 4488 FT

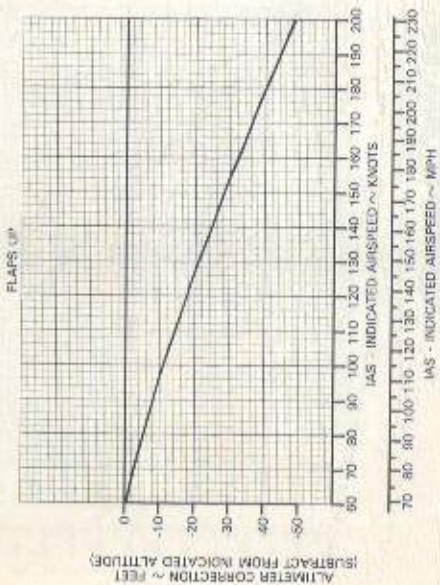
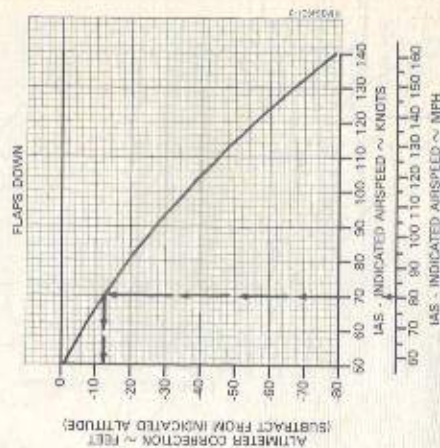

ALTIMETER CORRECTION - EMERGENCY SYSTEM

EXAMPLE

IAS 100 KTS (81 MPH)
 STORM WINDOW OPEN
 INDICATED PRESSURE ALTITUDE 5000 FT
 ALTITUDE CORRECTED FROM 39 FT
 ACTUAL PRESSURE ALTITUDE 5000 - 39 = 4961 FT

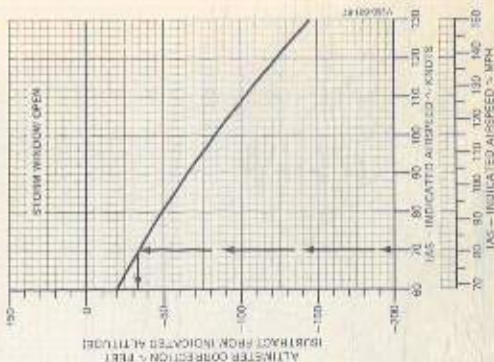

NOTES: 1. INDICATED AIRSPEED AND INDICATED ALTITUDE ASSUMES ZERO INSTRUMENT ERROR.
 2. APPLICABLE FOR ALL MOUNTING POSITIONS.

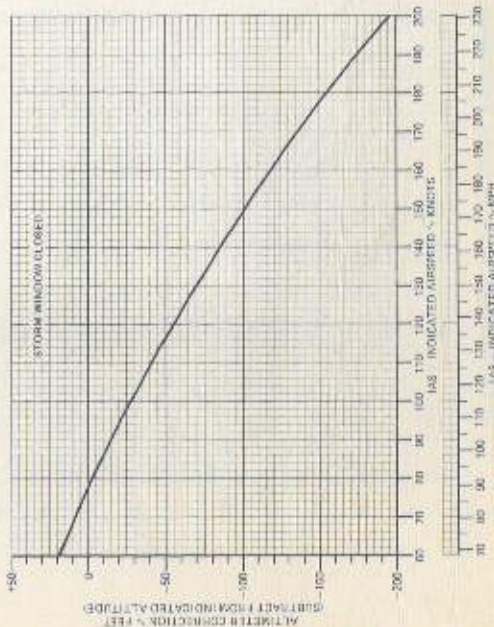

FAHRENHEIT TO CELSIUS TEMPERATURE CONVERSION

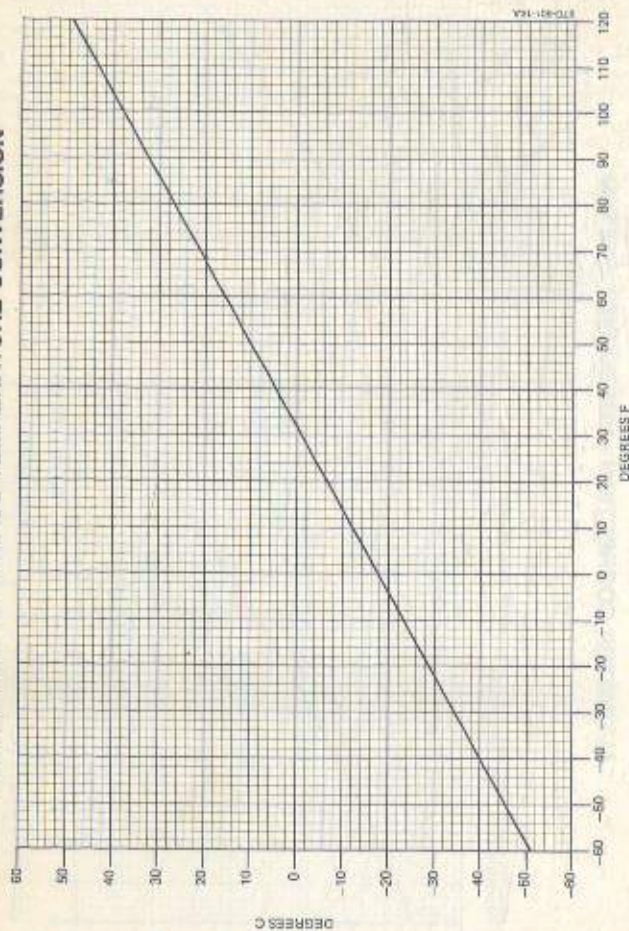

ISA CONVERSION

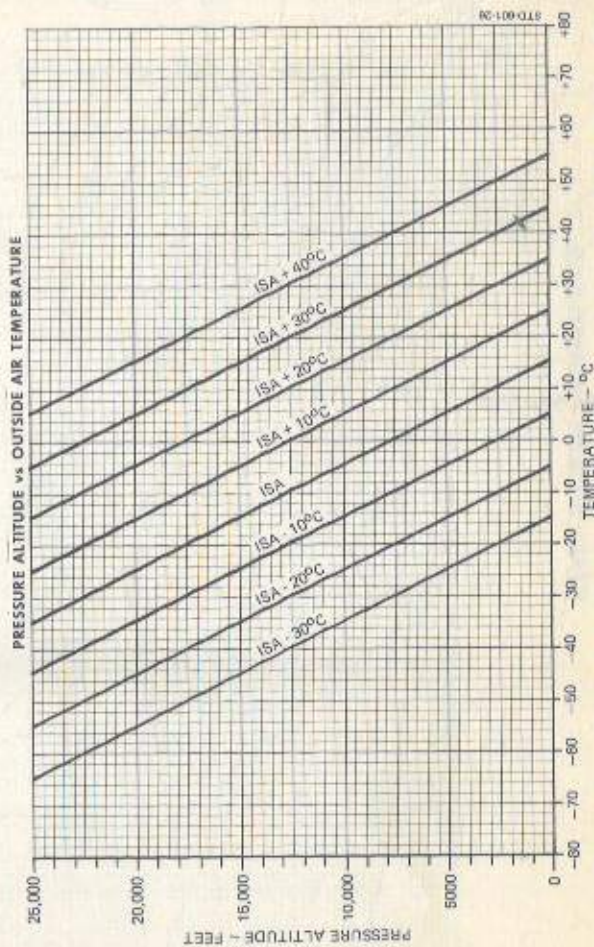

WIND COMPONENTS

Demonstrated Crosswind Component is 17 kts

EXAMPLE:

WIND SPEED	20 KTS
ANGLE BETWEEN WIND DIRECTION AND FLIGHT PATH	50°
HEADWIND COMPONENT	13 KTS
CROSSWIND COMPONENT	15 KTS

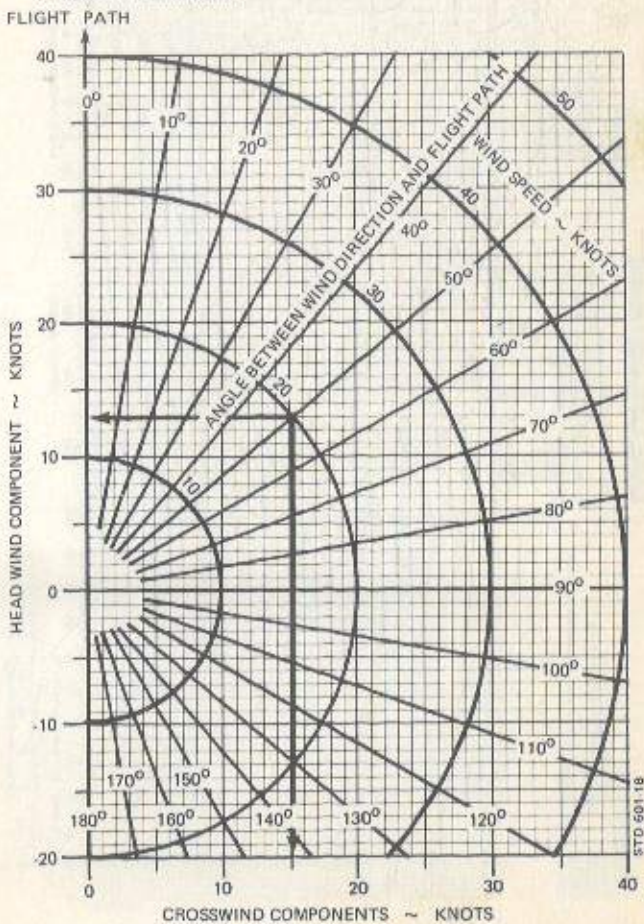

Section V
Performance

BEECHCRAFT Bonanza F33A
CE-674 and after

TAKE-OFF DISTANCE

ASSOCIATED CONDITIONS
 POWER FULL THROTTLE AT 2000 RPM
 FLAPS UP TO APPROXIMATE 10°
 LANDING GEAR RETRACT AFTER POSITIVE CLIMB ESTABLISHED
 GWSL FLAPS UP

HEIGHT - FEET	WINDSPEED KNOTS		WINDSPEED MPH	
	1/2	3/4	1/2	3/4
3400	21	27	38	43
3200	22	27	36	41
3000	23	27	34	39
2800	24	28	32	37
2600	25	29	30	35
2400	26	30	28	33

EXAMPLE

QAS 1570 (RPM)
 WIND 14 KTS
 ALTITUDE 3.5 KTS
 ROAD WIND COMPONENT 0
 GROSS WEIGHT 3000 LBS
 TOTAL DISTANCE OVER A 50' HURDLE 2000 FT
 TAKE-OFF SPEED AT LIFT-OFF 77 KTS (140 MPH)
 CLIMB 30 MPH

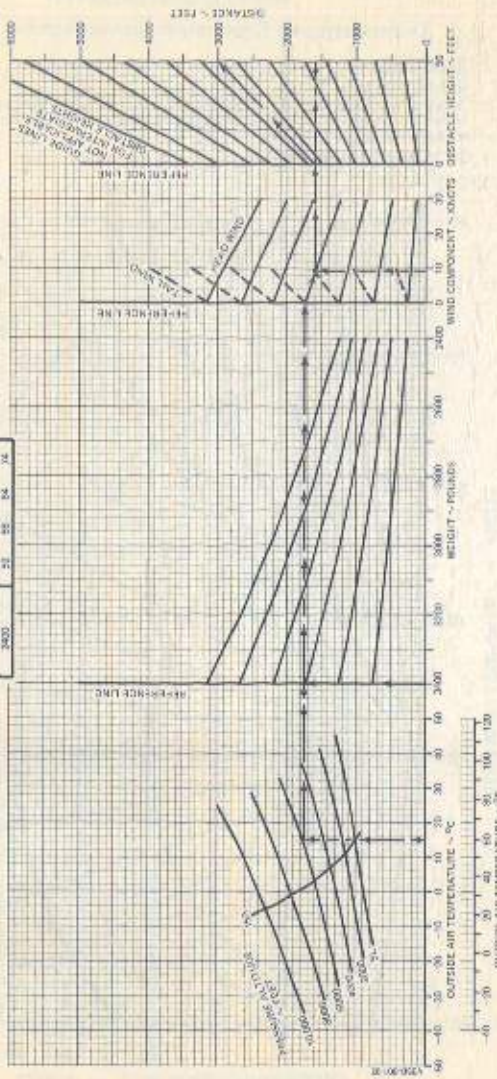

CLIMB

ASSOCIATED CONDITIONS:

- POWER FULL THROTTLE AT
- GEAR DOWN
- WING FLAPS SET TO APPROPRIATE
- LANDING GEAR UP
- COAST FLAPS AS REQUIRED

CLIMB SPEED 96 KNOTS (110 MPH) BAG (ALL WEIGHTS)

✓ NORMALS EXCEPT THIRD GEAR WITH 3- OR SALAGE PROPELLER INSTALLED
 AND CL-155 AND AFTER WITH 3-SALAGE PROPELLER INSTALLED
 AND CL-155 AND AFTER WITH 3-SALAGE PROPELLER INSTALLED
 AND CL-155 AND AFTER WITH 3-SALAGE PROPELLER INSTALLED

- EXAMPLE:**
- DAT 50 (231)
 - PRESSURE ALTITUDE 1,500 FT
 - WEIGHT 3000 LBS

- RATE-OF-CLIMB 410 FT/MIN
- CLIMB GRADIENT 4.1%
- CLIMB SPEED 26 KNOTS (30 MPH)

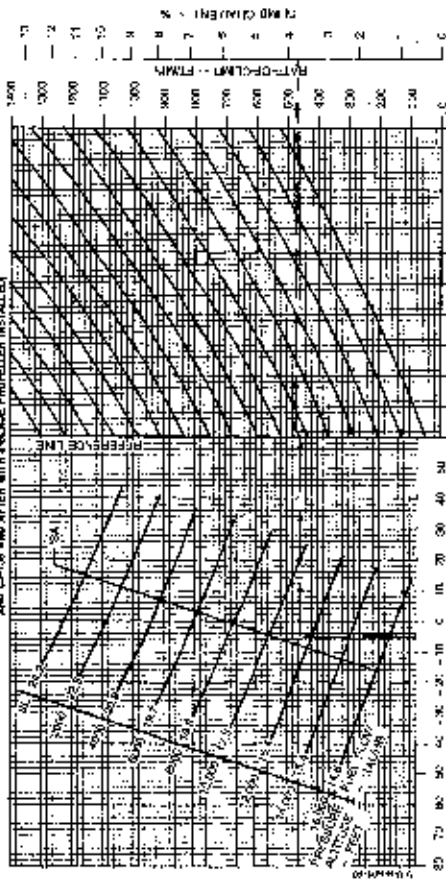

OUTSIDE AIR TEMPERATURE °F
 80 70 60 50 40 30 20 10 0 -10 -20 -30 -40 -50 -60

WEIGHT POUNDS
 3400 3200 3000 2800 2600 2400 2200 2000 1800 1600 1400 1200 1000 800 600 400 200 0

RATE OF CLIMB - FT/MIN
 1500 1000 500 0 500 1000 1500

CLIMB GRADIENT - %
 8 7 6 5 4 3 2 1 0

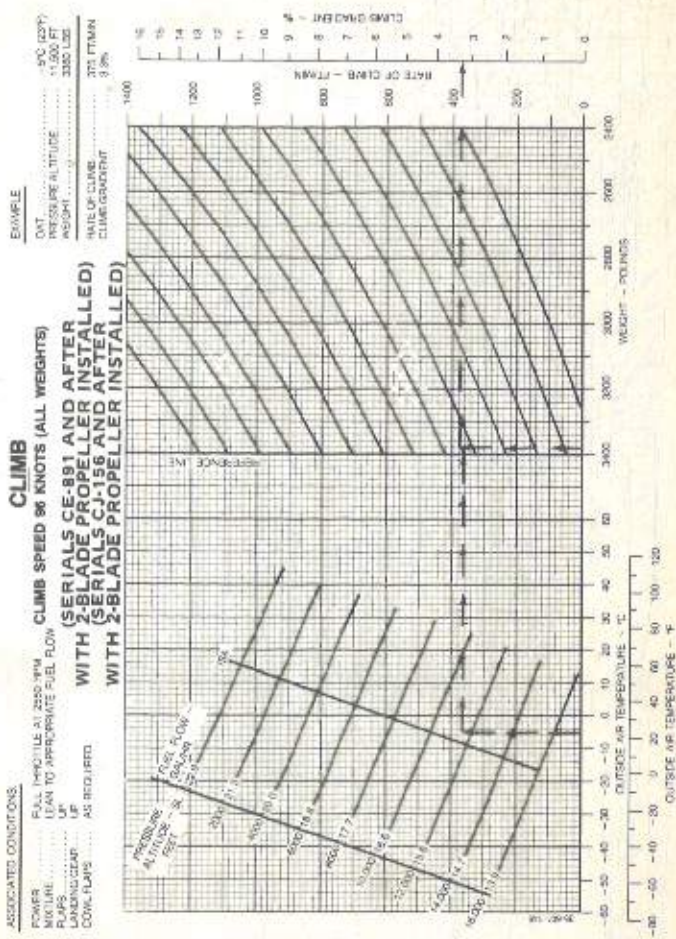

Section V
Performance

BEECHCRAFT Bonanza F33A
CE-674 and after

**TIME, FUEL, AND DISTANCE
TO CLIMB**

CLIMB SPEED - 107 KNOTS (123 MPH)

ASSOCIATED CONDITIONS:

- POWER - 25 HP, MCGR CELL THROTTLE 2000 RPM
- FUEL TEMPERATURE - 60 °F (15 °C)
- FUEL FLOW - 10 GPH (38 LPH) AT APPROPRIATE FUEL FLOW
- DOWN DRAGS - CLOSED

EXAMPLE:

- DAY AT TAKE-OFF 15°C
- DAY AT CRUISE -5°C
- ALTITUDE 3880 FT.
- INITIAL FUEL 30.0 GAL.
- INITIAL CLIMB WEIGHT 3100 LB.
- TIME TO CLIMB TO 31 13 MIN.
- FUEL TO CLIMB TO 31 2.681 GAL.
- DISTANCE TO CLIMB TO 31 27 NM.

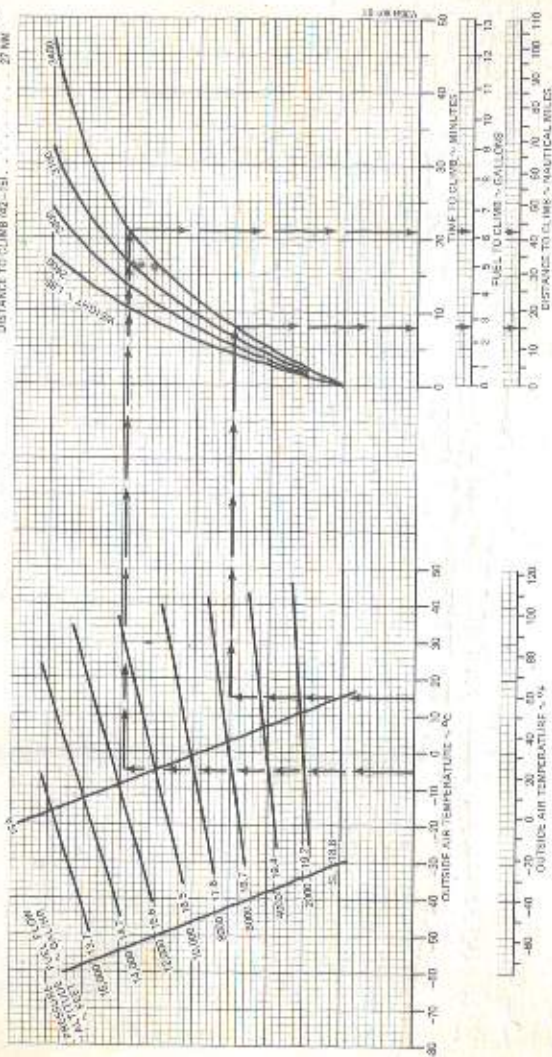

CRUISE POWER SETTINGS

85% MAXIMUM CONTINUOUS POWER (OR FULL THROTTLE) 2500 RPM
3200 POUNDS

PRESS ALT.	ISA -36°F (-20°C)										STANDARD DAY (ISA)										ISA +36°F (+20°C)									
	ENGINE SPEED PRESS.		FUEL FLOW		TAS		CAS		IOAT		ENGINE SPEED PRESS.		FUEL FLOW		TAS		CAS		IOAT		ENGINE SPEED PRESS.		FUEL FLOW		TAS		CAS			
	°C	RPM	IN HG	PPH	GPH	KTS	KTS	°C	RPM	IN HG	PPH	GPH	KTS	KTS	°C	RPM	IN HG	PPH	GPH	KTS	KTS	°C	RPM	IN HG	PPH	GPH	KTS	KTS		
SL	27	3	2300	23.3	80.0	13.3	150	156	63	17	2300	23.9	80.0	13.3	154	163	95	37	2300	24.5	80.0	13.3	156	161						
1000	25	5	2300	25.1	80.0	13.3	152	155	59	15	2300	23.6	80.0	13.3	155	162	96	35	2300	24.2	80.0	13.3	158	160						
2000	20	-7	2300	22.8	80.0	13.3	153	154	56	13	2300	23.4	80.0	13.3	158	162	82	33	2300	24.0	80.0	13.3	159	162						
3000	16	-9	2300	22.5	80.0	13.3	154	153	52	11	2300	23.1	80.0	13.3	167	161	89	31	2300	23.7	80.0	13.3	160	148						
4000	13	-11	2300	22.2	80.0	13.3	155	152	48	9	2300	22.8	80.0	13.3	169	150	85	29	2300	23.5	80.0	13.3	161	147						
5000	9	-13	2300	22.0	80.0	13.3	156	151	45	7	2300	22.6	80.0	13.3	169	148	82	28	2300	23.2	80.0	13.3	163	146						
6000	6	-15	2300	21.8	80.0	13.3	158	150	42	6	2300	22.4	80.0	13.3	181	147	78	26	2300	23.0	80.0	13.3	164	145						
7000	2	-17	2300	21.5	80.0	13.3	159	149	38	4	2300	22.1	80.0	13.3	182	146	75	24	2300	22.8	80.0	13.3	164	143						
8000	-1	-18	2300	21.3	80.0	13.3	160	148	35	2	2300	21.7	80.0	13.3	183	144	71	22	2300	21.7	80.0	13.3	163	139						
9000	-5	-20	2300	20.8	78.1	13.0	160	146	31	0	2300	20.9	76.4	13.7	181	141	67	20	2300	20.9	78.8	12.3	161	136						
10000	-8	-22	2300	20.0	76.2	12.7	159	143	28	-2	2300	20.0	73.8	12.9	180	138	64	18	2300	20.0	71.4	11.9	159	132						
11000	-12	-24	2300	19.2	73.8	12.3	158	139	24	-4	2300	19.2	71.4	11.9	158	134	60	16	2300	19.2	69.1	11.3	158	129						
12000	-16	-27	2300	18.4	71.3	11.9	157	136	20	-7	2300	18.4	69.2	11.5	157	131	56	13	2300	18.4	66.8	10.8	153	126						
13000	-19	-29	2300	17.6	68.8	11.5	156	132	17	-9	2300	17.6	66.8	11.1	156	127	53	11	2300	17.6	64.5	10.4	153	121						
14000	-23	-31	2300	16.8	66.4	11.1	155	129	13	-11	2300	16.8	64.4	10.7	152	123	49	8	2300	16.8	62.1	10.0	151	117						
15000	-27	-33	2300	16.1	64.0	10.7	151	125	8	-13	2300	16.1	62.1	10.4	150	119	45	7	2300	16.1	60.0	10.0	147	113						
16000	-30	-35	2300	15.5	61.9	10.3	148	121	8	-15	2300	15.5	60.0	10.0	147	116														

NOTES: 1. Fuel throttle method/pressure settings are approximate.
2. Shaded area represents operation with full throttle.

CRUISE POWER SETTINGS

55% MAXIMUM CONTINUOUS POWER (OR FULL THROTTLE) 2100 RPM
5200 POUNDS

WIND ALT.	ISA -36°F (-30°C)										STANDARD DAY (ISA)										ISA +36°F (+30°C)																		
	ENGINE SPEED		MAN. PRESS.		FUEL FLOW		TAS		CAS		IDAT		ENGINE SPEED		MAN. PRESS.		FUEL FLOW		TAS		CAS		IDAT		ENGINE SPEED		MAN. PRESS.		FUEL FLOW		TAS		CAS						
	°C	RPM	IN HG	PPH	GPH	KTS	KTS	°C	RPM	IN HG	PPH	GPH	KTS	KTS	°C	RPM	IN HG	PPH	GPH	KTS	KTS	°C	RPM	IN HG	PPH	GPH	KTS	KTS	°C	RPM	IN HG	PPH	GPH	KTS	KTS				
SL	26	2100	25.0	68.8	11.5	140	145	62	17	2100	25.8	69.8	11.5	143	143	59	37	2100	24.2	68.8	11.5	145	140	55	37	2100	24.2	68.8	11.5	145	140	55	37	2100	24.2	68.8	11.5	145	140
1000	23	2100	22.8	66.5	11.5	141	144	59	15	2100	23.3	68.3	11.5	144	142	39	35	2100	24.0	68.8	11.5	145	138	55	35	2100	23.7	68.0	11.5	147	138	55	35	2100	23.7	68.0	11.5	147	138
2000	19	2100	22.5	66.5	11.5	142	143	55	13	2100	23.1	68.2	11.5	145	141	31	33	2100	23.7	68.0	11.5	145	138	55	33	2100	23.7	68.0	11.5	145	138	55	33	2100	23.7	68.0	11.5	145	138
3000	16	2100	22.3	66.8	11.5	143	142	52	11	2100	22.9	69.8	11.5	146	140	28	31	2100	25.5	68.8	11.5	148	137	55	31	2100	25.5	68.8	11.5	148	137	55	31	2100	25.5	68.8	11.5	148	137
4000	12	2100	22.1	68.8	11.5	144	141	48	9	2100	22.6	68.0	11.5	147	139	24	29	2100	23.0	68.8	11.5	149	135	55	27	2100	23.0	68.8	11.5	149	135	55	27	2100	23.0	68.8	11.5	149	135
5000	8	2100	21.8	68.8	11.5	145	140	45	7	2100	22.4	68.5	11.5	148	137	21	27	2100	23.0	68.8	11.5	148	137	55	27	2100	23.0	68.8	11.5	148	137	55	27	2100	23.0	68.8	11.5	148	137
6000	5	2100	21.5	68.8	11.5	146	139	41	5	2100	22.1	68.5	11.5	149	135	19	25	2100	22.7	68.8	11.5	149	135	55	25	2100	22.7	68.8	11.5	149	135	55	25	2100	22.7	68.8	11.5	149	135
7000	2	2100	21.3	68.2	11.5	147	138	38	3	2100	21.9	68.8	11.5	149	135	17	23	2100	22.3	68.8	11.5	149	135	55	23	2100	22.3	68.8	11.5	149	135	55	23	2100	22.3	68.8	11.5	149	135
8000	-2	2100	21.1	68.8	11.5	148	137	34	1	2100	21.5	68.0	11.5	150	133	15	21	2100	22.0	68.8	11.5	150	133	55	21	2100	22.0	68.8	11.5	150	133	55	21	2100	22.0	68.8	11.5	150	133
9000	-8	2100	20.9	68.4	11.4	149	135	27	-1	2100	21.0	67.5	11.3	149	131	11	19	2100	21.0	68.8	11.5	150	128	55	19	2100	21.0	68.8	11.5	150	128	55	19	2100	21.0	68.8	11.5	150	128
10000	-9	2100	20.1	66.0	11.3	149	133	21	-3	2100	20.2	65.8	11.3	148	126	6	17	2100	20.1	68.8	11.5	150	125	55	17	2100	20.1	68.8	11.5	150	125	55	17	2100	20.1	68.8	11.5	150	125
11000	-15	2100	19.3	66.0	11.2	147	130	21	-5	2100	19.3	64.0	10.7	147	124	5	15	2100	19.3	68.8	11.5	150	120	55	15	2100	19.3	68.8	11.5	150	120	55	15	2100	19.3	68.8	11.5	150	120
12000	-19	2100	18.5	64.0	10.7	148	120	19	-7	2100	18.5	61.1	10.4	148	117	5	13	2100	18.5	68.8	11.5	150	114	55	13	2100	18.5	68.8	11.5	150	114	55	13	2100	18.5	68.8	11.5	150	114
13000	-26	2100	17.7	62.0	10.3	144	123	16	-9	2100	17.7	60.2	10.0	142	117	3	11	2100	17.7	68.8	11.5	150	112	55	11	2100	17.7	68.8	11.5	150	112	55	11	2100	17.7	68.8	11.5	150	112
14000	-34	2100	16.9	60.8	10.0	141	119	12	-11	2100	16.8	57.9	9.7	139	112																								
16000	-47	2100	16.2	57.6	8.8	138	114																																
18000	-51	2100	15.8	55.8	8.2	135	115																																

NOTES:
1. Full throttle mixture pressure settings are approximate.
2. Standard area represents operation with full throttle.

CRUISE POWER SETTINGS

85% MAXIMUM CONTINUOUS POWER (OR FULL THROTTLE) 2100 RPM
3200 POUNDS

PRESS ALT	ISA -36°F (-20°C)										STANDARD DAY (SA)										ISA -36°F (-20°C)															
	ENGINE SPEED PRESS.			FUEL FLOW			TAS			CAS			ENGINE SPEED PRESS.			FUEL FLOW			TAS			CAS			ENGINE SPEED PRESS.			FUEL FLOW			TAS			CAS		
	FOOT	F	C	RPM	IN HG	PPH	GPH	KTS	MPH	MPH	MPH	F	C	RPM	IN HG	PPH	GPH	KTS	MPH	MPH	MPH	F	C	RPM	IN HG	PPH	GPH	KTS	MPH	MPH	MPH					
3,100	-4	-4	2100	20.4	57.5	9.8	127	132	63	17	2100	20.2	57.8	9.8	130	130	58	37	2100	21.2	57.6	9.6	132	127	2100	21.2	57.6	9.6	132	127	57.6	132	127			
4,000	-6	-6	2100	20.1	57.8	9.8	128	131	58	15	2100	20.5	57.6	9.8	131	129	58	30	2100	20.9	57.8	9.6	133	126	2100	20.9	57.8	9.6	133	126	57.8	133	126			
5,000	-7	-7	2100	19.8	57.6	9.8	129	130	55	13	2100	20.2	57.6	9.8	131	128	51	33	2100	20.6	57.6	9.6	132	125	2100	20.6	57.6	9.6	132	125	57.6	132	125			
6,000	-9	-9	2100	19.4	57.6	9.6	129	127	51	11	2100	19.9	57.8	9.6	130	127	47	31	2100	20.3	57.6	9.6	134	124	2100	20.3	57.6	9.6	134	124	57.6	134	124			
7,000	-11	-11	2100	19.1	57.8	9.6	131	128	48	9	2100	19.6	57.6	9.6	133	128	44	28	2100	20.0	57.8	9.6	135	127	2100	20.0	57.8	9.6	135	127	57.8	135	127			
8,000	-13	-13	2100	18.9	57.6	9.6	132	127	44	7	2100	19.3	57.6	9.6	134	128	40	27	2100	19.7	57.6	9.6	138	122	2100	19.7	57.6	9.6	138	122	57.6	138	122			
9,000	-15	-15	2100	18.6	57.8	9.6	133	126	41	5	2100	19.0	57.8	9.6	135	123	37	25	2100	19.4	57.8	9.6	140	120	2100	19.4	57.8	9.6	140	120	57.8	140	120			
10,000	-17	-17	2100	18.2	57.5	9.6	134	125	37	3	2100	18.7	57.6	9.6	135	122	33	23	2100	19.1	57.8	9.6	143	119	2100	19.1	57.8	9.6	143	119	57.8	143	119			
11,000	-19	-19	2100	17.9	57.6	9.6	134	124	34	1	2100	18.4	57.6	9.6	136	121	30	21	2100	18.8	57.6	9.6	146	118	2100	18.8	57.6	9.6	146	118	57.6	146	118			
12,000	-21	-21	2100	17.6	57.8	9.6	135	123	30	-1	2100	18.1	57.6	9.6	137	120	26	19	2100	18.3	57.8	9.6	149	116	2100	18.3	57.8	9.6	149	116	57.8	149	116			
13,000	-23	-23	2100	17.3	57.5	9.6	136	122	26	-3	2100	17.8	57.6	9.6	137	118	23	17	2100	18.2	57.6	9.6	152	115	2100	18.2	57.6	9.6	152	115	57.6	152	115			
14,000	-25	-25	2100	17.0	57.6	9.6	136	120	23	5	2100	17.5	57.6	9.6	138	117	20	15	2100	17.9	57.6	9.6	155	113	2100	17.9	57.6	9.6	155	113	57.6	155	113			
15,000	-27	-27	2100	16.7	57.6	9.6	137	119	19	-7	2100	17.2	57.6	9.6	138	115	17	13	2100	18.0	57.6	9.6	158	111	2100	18.0	57.6	9.6	158	111	57.6	158	111			
16,000	-29	-29	2100	16.4	57.6	9.6	137	117	16	-9	2100	16.8	57.8	9.6	139	113	14	11	2100	17.8	57.6	9.6	161	110	2100	17.8	57.6	9.6	161	110	57.6	161	110			
17,000	-31	-31	2100	16.1	57.5	9.6	138	116	13	-11	2100	16.5	57.8	9.6	140	110	11	9	2100	17.8	57.6	9.6	164	108	2100	17.8	57.6	9.6	164	108	57.6	164	108			
18,000	-33	-33	2100	15.8	57.6	9.6	138	114	10	-13	2100	16.2	57.8	9.6	141	108	8	7	2100	17.8	57.6	9.6	167	106	2100	17.8	57.6	9.6	167	106	57.6	167	106			

NOTES:
1. Full throttle manifold pressure settings are approximate.
2. Shaded area represents operation with full throttle.

CRUISE SPEEDS

ASSOCIATED CONDITIONS:

AVERAGE CRUISE WEIGHT 3200 LBS
TEMPERATURE STANDARD DAY (ISA)

EXAMPLE

PRESSURE ALTITUDE 11,800 FT
POWER SETTING . . . FULL THROTTLE 2600 RPM
TRUE AIRSPEED . . . 156 KTS

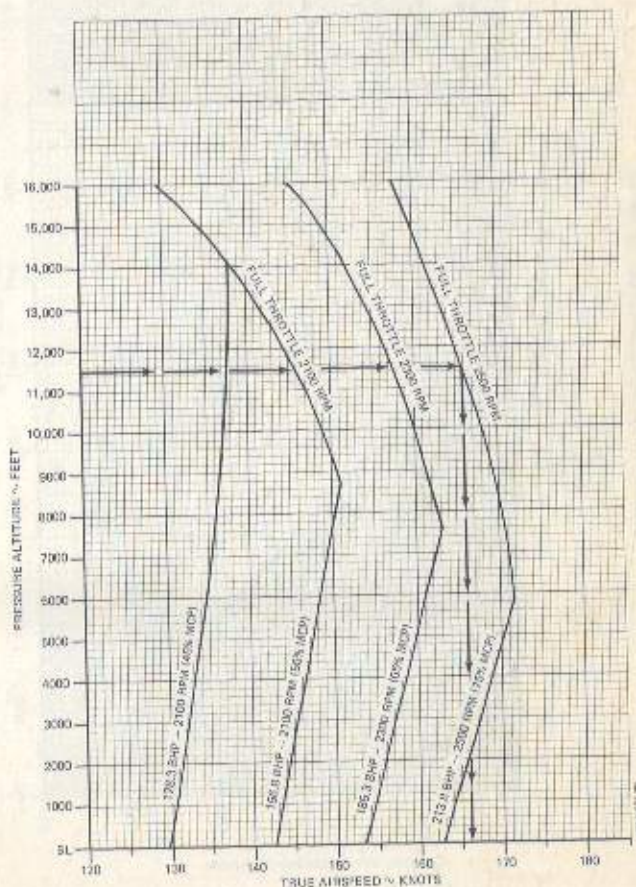

MANIFOLD PRESSURE vs RPM

EXAMPLE:

ENGINE SPEED 2450 RPM
MANIFOLD PRESSURE 24.5 IN. HG

WITHIN RECOMMENDED LIMITS

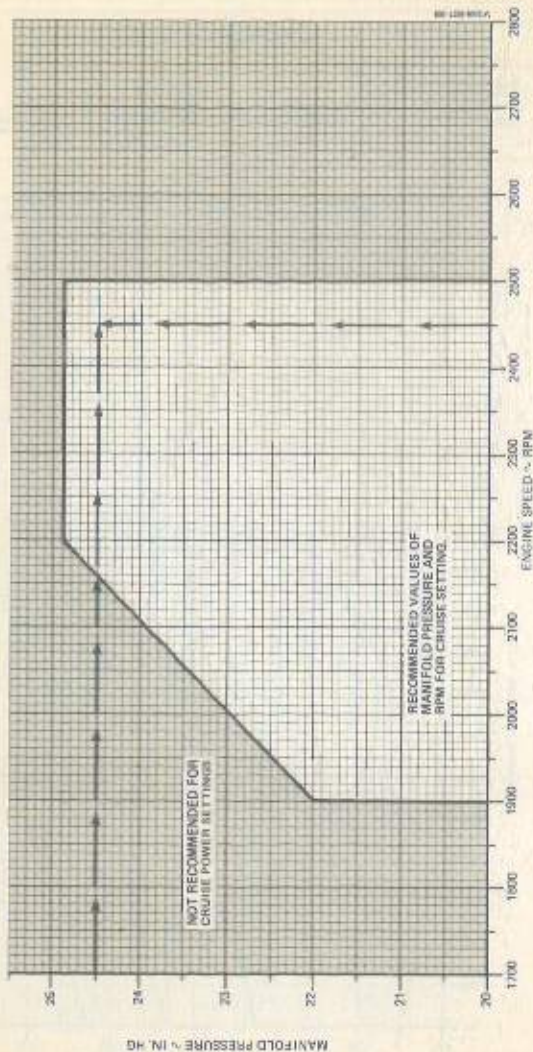

FUEL FLOW vs BRAKE HORSEPOWER

EXAMPLE:

1. BRAKE HORSEPOWER 213.75
 CONDITION LEVEL FLIGHT CRUISE
 FUEL FLOW 15.25 GAL./HR
2. FUEL FLOW 14.8 GAL./HR
 CONDITION LEVEL FLIGHT CRUISE
 BRAKE HORSEPOWER 204

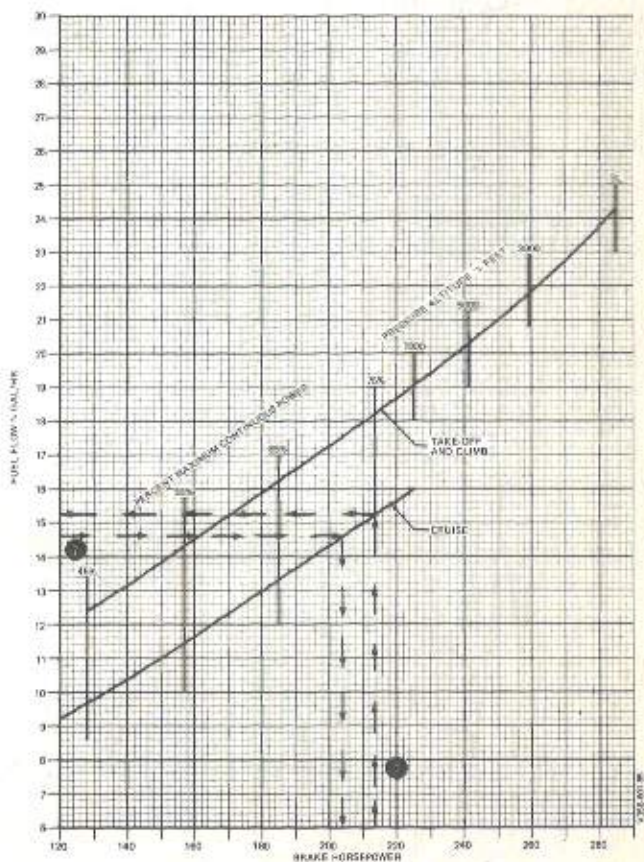

Section V
Performance

BEECHCRAFT Bonanza F33A
CE-674 and after

RANGE PROFILE - 74 GALLONS

STANDARD DAY (ISA)

ASSOCIATED CONDITIONS

WEIGHT 3412 LBS BEFORE ENGINE START
FUEL AVIATION GASOLINE
FUEL DENSITY 6.0 LBS/GAL
INITIAL FUEL LOADING 74 U.S. GAL (444 LBS)

EXAMPLE

PRESS. ALTITUDE 10,000 FT
POWER SETTING FULL THROTTLE 2000 RPM
RANGE 800 NM

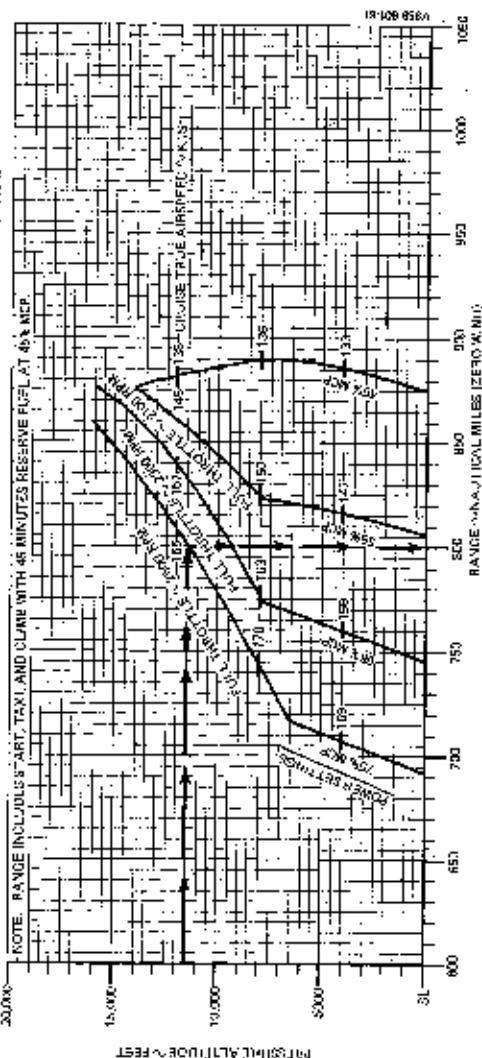

RANGE PROFILE - 44 GALLONS

STANDARD DAY (ISA)

ASSOCIATED CONDITIONS:

- WEIGHT 3412 LBS BEFORE ENGINE START
- FUEL AVIATION GASOLINE
- FUEL DENSITY 8.0 LBS/GAL
- INITIAL FUEL LOADING 44 U.S. GAL (284 LBS)

EXAMPLE:

- PRESSURE ALTITUDE 11,000 FT
- POWER SETTING FULL THROTTLE, 2500 RPM
- RANGE 413 NM

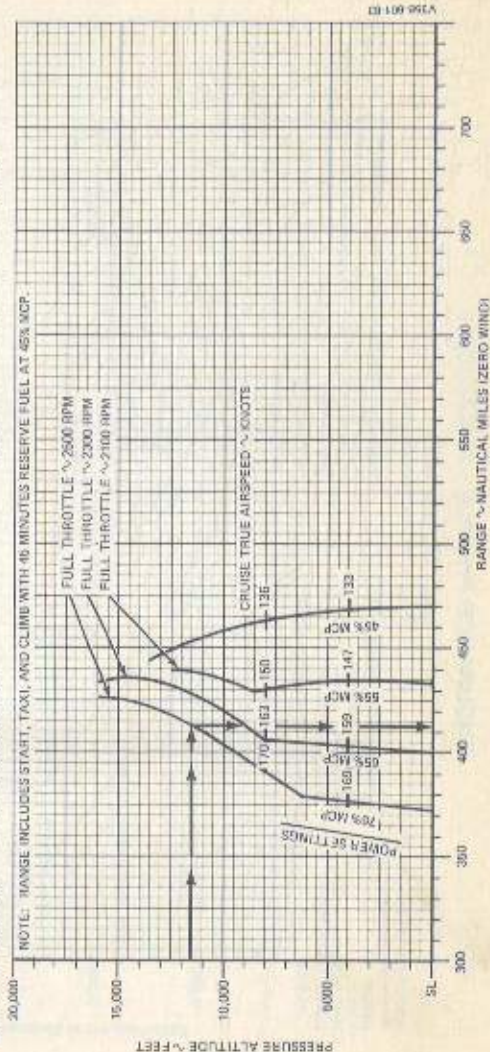

ENDURANCE PROFILE - 74 GALLONS

STANDARD DAY (ISA)

ASSOCIATED CONDITIONS:

WEIGHT 3412 LBS BEFORE ENGINE START
FUEL AVIATION GASOLINE
FUEL DENSITY 6.0 LBS/GAL
INITIAL FUEL LOADING 74 U.S. GAL (444 LBS)

EXAMPLE:

PRESSURE ALTITUDE 11,500 FT
POWER SETTING FULL THROTTLE, 2000 RPM
ENDURANCE 4.9 HRS (4 HRS 54 MIN)

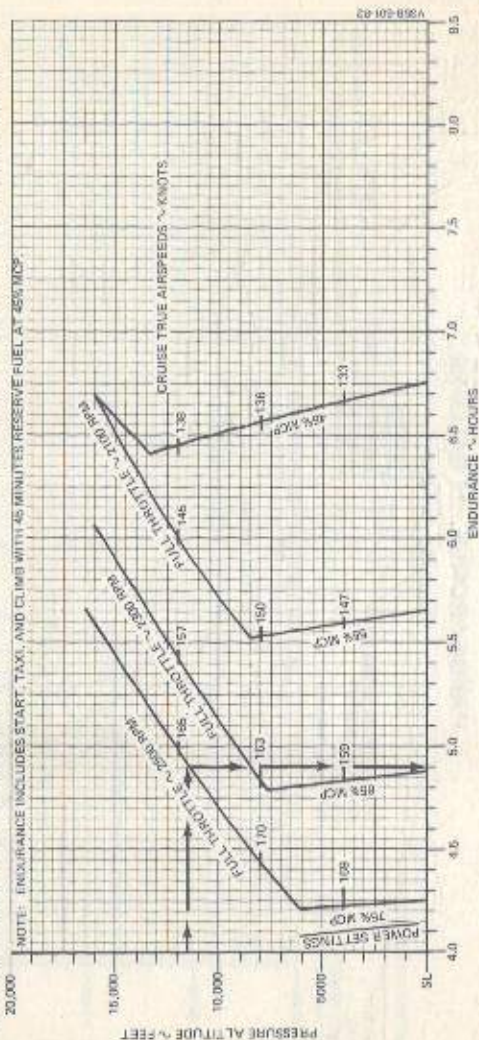

ENDURANCE PROFILE - 44 GALLONS

STANDARD DAY (15A)

ASSOCIATED CONDITIONS:

WEIGHT 3412 LBS BEFORE ENGINE START
FUEL AVIATION GASOLINE
FUEL DENSITY 6.0 LBS/GAL
INITIAL FUEL LOADING 44 U.S. GAL (264 LBS)

EXAMPLE:

PRESSURE ALTITUDE 11,500 FT
POWER SETTING FULL THROTTLE/2600 RPM
ENDURANCE 2.07 HRS (2 HRS 34 MIN)

NOTE: ENDURANCE INCLUDES START, TAXI, AND CLIMB WITH 45 MINUTES RESERVE FUEL AT 40% MCP.

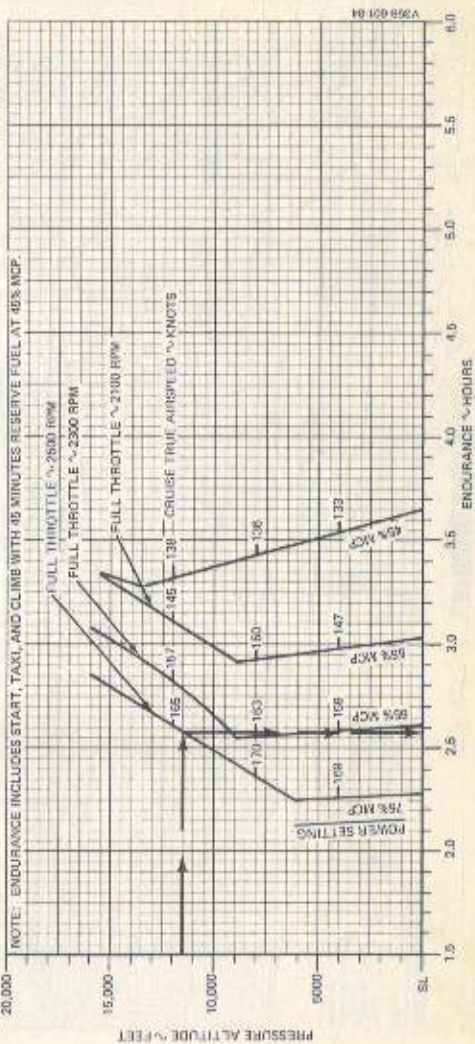

Section V
Performance

BEECHCRAFT Bonanza F33A
CE-674 and after

LANDING DISTANCE

ASSOCIATED CONDITIONS:
POWER FULL
FLAPS 30°
LANDING GEAR DOWN
AIRSPEED BRK ON
BRAKING MAXIMUM

RELATED TO MAXIMUM
300 FT / MIN OF FINAL APPROACH
3000' / MIN OF FINAL APPROACH
MAXIMUM WIND COMPONENT
MAXIMUM WIND COMPONENT
MAXIMUM WIND COMPONENT

WEIGHT - LBS	SPEED - KTS	SPEED - MPH
2400	70	81
2500	70	80
2600	68	78
2700	67	77
2800	65	75
2900	64	74
3000	62	71
3100	61	70
3200	59	68

EXAMPLE:

DAT 2000 FT
PRESSURE ALTITUDE 3000 FT
WIND COMPONENT 10 KTS
WIND DIRECTION 135°
TOTAL LANDING DISTANCE 1350 FT
APPROACH SPEED 65 KTS (80 MPH)

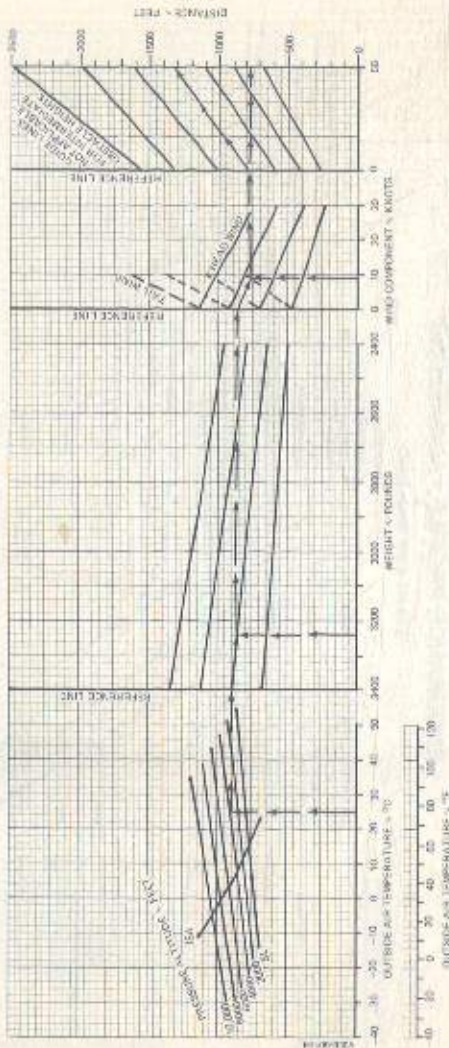

SECTION VI

WEIGHT AND BALANCE/ EQUIPMENT LIST

TABLE OF CONTENTS

<i>SUBJECT</i>	<i>PAGE</i>
Weighing Instructions	6-3
Basic Empty Weight And Balance Form.....	6-5
Weight and Balance Record	6-7
Loading Instructions.....	6-9
Moment Limits vs Weight Graph	6-11
Computing Procedure.....	6-12
Sample Weight And Balance Loading Form.....	6-13
Weight and Balance Loading Form	6-14
Useful Load Weights And Moments	
Occupants.....	6-15
Baggage and Cargo	6-16
Usable Fuel	6-17
Equipment List	Provided for each airplane

WEIGHING INSTRUCTIONS

Periodic weighing of the Bonanza F33A may be required to keep the Basic Empty Weight current. All changes to the airplane affecting weight and balance are the responsibility of the airplane's operator.

1. Three jack points are provided for weighing; two on the wing front spar at Fuselage Station 83.1 and one on the aft fuselage at Fuselage Station 271.0.

2. Fuel should be drained preparatory to weighing. Tanks are drained from the regular drain ports with the airplane in static ground attitude. When tanks are drained, 1.5 pounds of undrainable fuel remain in the airplane at Fuselage Station 76.0. The remainder of the unusable fuel to be added to a Basic Empty Weight is 34.5 pounds at Fuselage Station 79.1.

3. Engine oil must be at the full level or completely drained. Total engine oil when full is 26 pounds at Fuselage Station 24.5. (Includes 3 pounds undrainable.)

4. To determine airplane configuration at time of weighing, installed equipment is checked against the airplane equipment list or superseding forms. All installed equipment must be in its proper place during weighing.

5. At the time of weighing, the airplane must be level both longitudinally and laterally, and the landing gear must be fully extended. Leveling screws are located on the left side of the fuselage at approximately Fuselage Station 152.25. Longitudinally level attitude is determined with a plumb bob. Laterally level attitude is obtained when the vertical distance from each wing tip to the floor is equal.

6. Measurement of the reaction arms for a wheel weighing is made using a steel measuring tape. Measurements are tak-

on, with the airplane level on the scales, from the reference (a plumb bob dropped from the center of either main jack point) to the axle center line of the main gear and then to the nose wheel axle center line. The main wheel axle center line is best located by stretching a string across from one main wheel to the other. All measurements are to be taken with the tape level with the hangar floor and parallel to the fuselage center line. The locations of the wheel reactions will be approximately at Fuselage Station 96.7 for main wheels and Fuselage Station 12.7 for the nose wheel.

7. Jack point weighings are accomplished by placing scales on the jack points specified in step 1 above. Since the center of gravity of the airplane is forward of Fuselage Station 83.1, the tail reaction of the airplane will be in an up direction. This can be measured on regular scales by placing ballast of approximately 200 pounds on the scales to which the aft weighing point is attached by cable of adjustable length. The up reaction will then be total ballast weight minus the scale reading and is entered in the weighing form as a negative quantity.

8. Weighing should always be made in an enclosed area which is free from air currents. The scales used should be properly calibrated and certified.

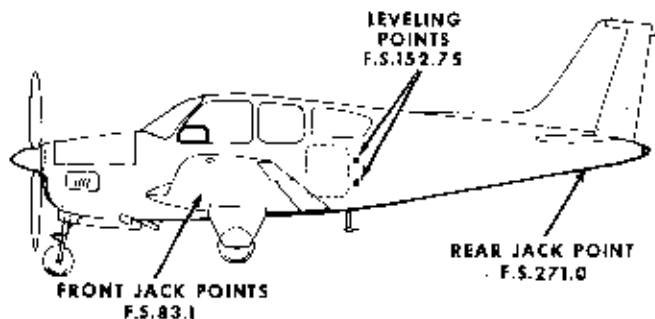

F33A-605-2

BASIC EMPTY WEIGHT AND BALANCE

BONANZA F33A SER. NO. _____ REG. NO. _____ DATE _____
 STRUT POSITION - NOSE MAIN JACK POINT LOCATION PREPARED BY
 EXTENDED 11.8 96 FORWARD 83.1 Company
 COMPRESSED 13.1 97 AFT 271.0 Signature

REACTION WHEEL - JACK POINTS	SCALE READING	TARE	NET WEIGHT	ARM	MOMENT
LEFT MAIN					
RIGHT MAIN					
NOSE OR TAIL					
TOTAL (AS WEIGHED)					
Space below provided for additions and subtractions to as - weighed condition					
EMPTY WEIGHT			26		638
ENGINE OIL			36		2844
UNUSABLE FUEL				79	
BASIC EMPTY WEIGHT					

NOTE

Each new airplane is delivered with a completed sample loading, basic empty weight and center of gravity, and equipment list, all pertinent to that specific airplane. It is the owner's responsibility to ensure that changes in equipment are reflected in a new weight and balance and in an addendum to the equipment list. There are many ways of doing this; it is suggested that a running tally of equipment changes and their effect on basic empty weight and CG is a suitable means for meeting both requirements.

That current equipment list and basic empty weight and CG information must be retained with the airplane when it changes ownership. Beech Aircraft Corporation cannot maintain this information; the current status is known only to the owner. If these papers become lost, the FAA will require that the airplane be re-weighed to establish the basic empty weight and CG and that an inventory of installed equipment be conducted to create a new equipment list.

LOADING INSTRUCTIONS

It is the responsibility of the airplane operator to ensure that the airplane is properly loaded. At the time of delivery, Beech Aircraft Corporation provides the necessary weight and balance data to compute individual loadings. All subsequent changes in airplane weight and balance are the responsibility of the airplane owner and/or operator.

The basic empty weight and moment of the airplane at the time of delivery are shown on the airplane Basic Empty Weight and Balance form. Useful load items which may be loaded into the airplane are shown on the Useful Load Weight and Moment tables. The minimum and maximum moments are indicated by the heavy border line on the Moment Limits vs Weight graph. These moments correspond to the forward and aft center of gravity flight limits for a particular weight. All moments are divided by 100 to simplify computations.

SEATING, BAGGAGE AND EQUIPMENT ARRANGEMENTS

PILOT & F. PASS	F.S.
FWD. POS. >	85
AFT POS.	89
3RD & 4TH SEAT PASS	
FWD. POS.	121
AFT POS.	127
5TH SEAT PASS	154

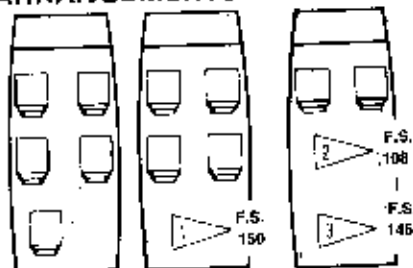

NOTE

The floor structure load limit is 100 pounds per square foot, except for the area between the front and rear spars, where the floor structure load limit is 50 pounds per square foot.

NOTE

All baggage/cargo must be secured with an approved cargo net.

- 1 MAXIMUM WEIGHT 270 POUNDS INCLUDING EQUIPMENT AND BAGGAGE WITH 5th SEAT REMOVED OR STOWED.
- 2 MAXIMUM WEIGHT 200 POUNDS FORWARD OF REAR SPAR INCLUDING EQUIPMENT AND CARGO WITH 3rd and 4th SEATS REMOVED.
- 3 MAXIMUM WEIGHT 270 POUNDS AFT OF REAR SPAR INCLUDING EQUIPMENT AND CARGO WITH 3rd, 4th and 5th SEATS REMOVED.

MOMENT LIMITS VS WEIGHT

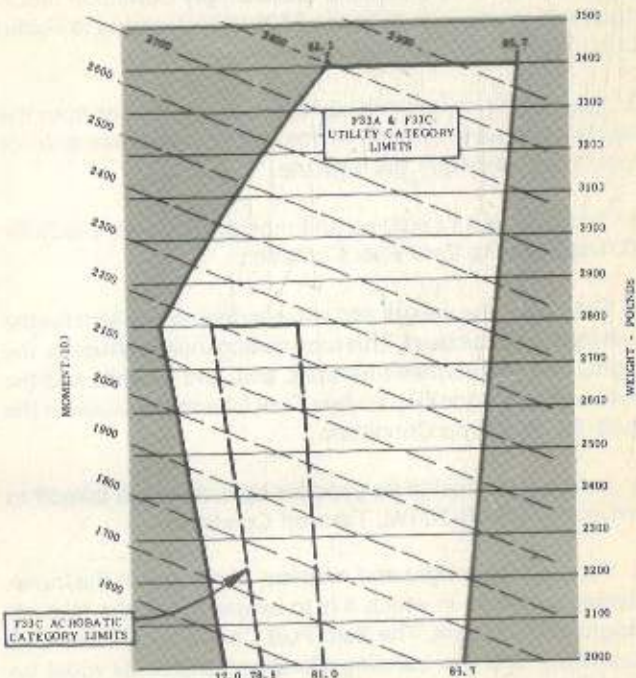

CENTER OF GRAVITY - INCHES AFT OF DATUM
ENVELOPE BASED ON THE FOLLOWING WEIGHT AND
CENTER OF GRAVITY LIMIT DATA (LANDING GEAR DOWN)

	WEIGHT CONDITION	FORWARD C.G. LIMIT	AFT C.G. LIMIT
F33A & F33C UTILITY CATEGORY	3400 LB. (MAXIMUM TAKE-OFF OR LANDING)	82.1	86.7
	2920 LB. OR LESS	72.0	86.7
F33C ACROBATIC CATEGORY	2850 LB. OR LESS	78.5	81.0

COMPUTING PROCEDURE

1. Record the Basic Empty Weight and Moment from the Basic Empty Weight and Balance form (or from the latest superseding form) under the Basic Empty Condition block. The moment must be divided by 100 to correspond to Useful Load Weights and Moments tables.
2. Record the weight and corresponding moment from the appropriate table of each of the useful load items (except fuel) to be carried in the airplane.
3. Total the weight column and moment column. The SUB-TOTALS are the Zero Fuel Condition.
4. Determine the weight and corresponding moment for the fuel loading to be used. This fuel loading includes fuel for the flight, plus that required for start, taxi, and takeoff. Add the Fuel Loading Condition to Zero Fuel Condition to obtain the SUB-TOTAL Ramp Condition.
5. Subtract the fuel to be used for start, taxi, and takeoff to arrive at the SUB-TOTAL Take-off Condition.
6. Subtract the weight and moment of the fuel in the incremental sequence in which it is to be used from the take-off weight and moment. The Zero Fuel Condition, the Take-off Condition, and the Landing Condition moments must be within the minimum and maximum moments shown on the Moment Limit vs Weight graph for that weight. If the total moment is less than the minimum moment allowed, useful load items must be shifted aft or forward load items reduced. If the total moment is greater than the maximum moment allowed, useful load items must be shifted forward or aft load items reduced. If the quantity or location of load items is changed, the calculations must be revised and the moments rechecked.

WEIGHT AND BALANCE LOADING FORM

BONANZA _____ DATE _____
SERIAL NO. _____ REG NO. _____

ITEM	WEIGHT	MOM/100
1. BASIC EMPTY CONDITION		
2. FRONT SEAT OCCUPANTS		
3. 3rd and 4th SEAT OCCUPANTS		
4. 5th SEAT OCCUPANT		
5. BAGGAGE		
6. CARGO		
7. SUB TOTAL ZERO FUEL CONDITION		
8. FUEL LOADING		
9. SUB TOTAL RAMP CONDITION		
10. *LESS FUEL FOR START, TAXI, AND RUN UP		
11. SUB TOTAL TAKE-OFF CONDITION		
12. LESS FUEL TO DESTINATION		
13. LANDING CONDITION		

*Fuel for start, taxi, and run up is normally 12 lbs at an average mom/100 of 9.

WEIGHT AND BALANCE LOADING FORM

BONANZA _____ DATE _____
SERIAL NO. _____ REG NO. _____

ITEM	WEIGHT	MOM/100
1. BASIC EMPTY CONDITION		
2. FRONT SEAT OCCUPANTS		
3. 3rd and 4th SEAT OCCUPANTS		
4. 5th SEAT OCCUPANT		
5. BAGGAGE		
6. CARGO		
7. SUB TOTAL ZERO FUEL CONDITION		
8. FUEL LOADING		
9. SUB TOTAL RAMP CONDITION		
10. *LESS FUEL FOR START, TAXI, AND RUN UP		
11. SUB TOTAL TAKE-OFF CONDITION		
12. LESS FUEL TO DESTINATION		
13. LANDING CONDITION		

*Fuel for start, taxi, and run up is normally 12 lbs at an average mom/100 of 9.

WEIGHT AND BALANCE LOADING FORM

BONANZA _____ DATE _____
SERIAL NO. _____ REG NO. _____

ITEM	WEIGHT	MOM/100
1. BASIC EMPTY CONDITION		
2. FRONT SEAT OCCUPANTS		
3. 3rd and 4th SEAT OCCUPANTS		
4. 5th SEAT OCCUPANT		
5. BAGGAGE		
6. CARGO		
7. SUB TOTAL ZERO FUEL CONDITION		
8. FUEL LOADING		
9. SUB TOTAL RAMP CONDITION		
10. *LESS FUEL FOR START, TAXI, AND TAKE-OFF		
11. SUB TOTAL TAKE-OFF CONDITION		
12. LESS FUEL TO DESTINATION		
13. LANDING CONDITION		

*Fuel for start, taxi and take-off is normally 12 lbs at an average mom/100 of 9.

WEIGHT AND BALANCE LOADING FORM

BONANZA _____ DATE _____
SERIAL NO. _____ REG NO. _____

ITEM	WEIGHT	MOM/100
1. BASIC EMPTY CONDITION		
2. FRONT SEAT OCCUPANTS		
3. 3rd and 4th SEAT OCCUPANTS		
4. 5th SEAT OCCUPANT		
5. BAGGAGE		
6. CARGO		
7. SUB TOTAL ZERO FUEL CONDITION		
8. FUEL LOADING		
9. SUB TOTAL RAMP CONDITION		
10. *LESS FUEL FOR START, TAXI, AND TAKE-OFF		
11. SUB TOTAL TAKE-OFF CONDITION		
12. LESS FUEL TO DESTINATION		
13. LANDING CONDITION		

*Fuel for start, taxi and take-off is normally 12 lbs at an average mom/100 of 9.

WEIGHT AND BALANCE LOADING FORM

BONANZA _____ DATE _____
SERIAL NO. _____ REG NO. _____

ITEM	WEIGHT	MOM/100
1. BASIC EMPTY CONDITION		
2. FRONT SEAT OCCUPANTS		
3. 3rd and 4th SEAT OCCUPANTS		
4. 5th SEAT OCCUPANT		
5. BAGGAGE		
6. CARGO		
7. SUB TOTAL ZERO FUEL CONDITION		
8. FUEL LOADING		
9. SUB TOTAL RAMP CONDITION		
10. *LESS FUEL FOR START, TAXI, AND TAKE-OFF		
11. SUB TOTAL TAKE-OFF CONDITION		
12. LESS FUEL TO DESTINATION		
13. LANDING CONDITION		

*Fuel for start, taxi and take-off is normally 12 lbs at an average mom/100 of 9.

WEIGHT AND BALANCE LOADING FORM

BONANZA _____ DATE _____
SERIAL NO. _____ REG NO. _____

ITEM	WEIGHT	MOM/100
1. BASIC EMPTY CONDITION		
2. FRONT SEAT OCCUPANTS		
3. 3rd and 4th SEAT OCCUPANTS		
4. 5th SEAT OCCUPANT		
5. BAGGAGE		
6. CARGO		
7. SUB TOTAL ZERO FUEL CONDITION		
8. FUEL LOADING		
9. SUB TOTAL RAMP CONDITION		
10. *LESS FUEL FOR START, TAXI, AND TAKE-OFF		
11. SUB TOTAL TAKE-OFF CONDITION		
12. LESS FUEL TO DESTINATION		
13. LANDING CONDITION		

*Fuel for start, taxi and take-off is normally 12 lbs at an average mom/100 of 9.

USEFUL LOAD WEIGHTS AND MOMENTS

WEIGHT	OCCUPANTS								5TH SEAT
	FRONT SEATS		3RD & 4TH SEATS				ARM 154	MOM/100	
	FWD. POSITION ARM 85	AFT POSITION ARM 89	FWD. POSITION ARM 121	AFT POSITION ARM 127	MOMENT/100				
					WEIGHT	MOM/100			
120	102	107	145	152	20	31			
130	110	116	157	165	40	62			
140	119	125	169	178	60	92			
150	128	134	182	190	80	123			
160	136	142	194	203	100	154			
170	144	151	206	216	120	185			
180	153	160	218	229	140	216			
190	162	169	230	241	160	246			
200	170	178	242	254	170	262			

NOTE: Occupant Positions for Adjustable Seats are shown at their extreme positions. Intermediate Positions will require interpolation of the Moment/100 Values.

USEFUL LOAD WEIGHTS AND MOMENTS

BAGGAGE		CARGO	
ARM 150		Fwd of Spar (3rd & 4th Seats Removed) ARM 108	Aft of Spar (3rd, 4th, & 5th Seats Removed) ARM 145
WEIGHT	MOM/100	MOM/100	MOM/100
10	15	11	15
20	30	22	29
30	45	32	44
40	60	43	58
50	75	54	73
60	90	65	87
70	105	76	102
80	120	86	116
90	135	97	131
100	150	108	145
110	165	119	160
120	180	130	174
130	195	140	189
140	210	151	203
150	225	162	218
160	240	173	232
170	255	184	247
180	270	194	261
190	285	205	276
200	300	216	290
210	315		305
220	330		319
230	345		334
240	360		348
250	375		363
260	390		377
270	405		392

USEFUL LOAD WEIGHTS AND MOMENTS

USABLE FUEL					
LEADING EDGE TANKS ARM 75					
GALLONS	WEIGHT	MOM/100	GALLONS	WEIGHT	MOM/100
5	30	23	44	264	198
10	60	45	50	300	225
15	90	68	55	330	248
20	120	90	60	360	270
25	150	113	65	390	293
30	180	135	70	420	315
35	210	158	74	444	333
40	240	180			

Use 2
weight
736#3
with
10/26/10



AIRCRAFT WEIGHT AND BALANCE REPORT

Jones Avionics FAA CRS #VWJR478Y

MAKE Beechcraft	MODEL F33A
REGISTRATION NO. N230DD	SERIAL NO. CE-635

ITEM DESCRIPTION	ITEM REMOVED				ITEM INSTALLED			
	Serial No.	Weight	Arm (Inches)	Moment	Serial No.	Weight	Arm (Inches)	Moment
GPS GNS430	9/103544	5.10	63.00	321.30				0.00
Indicator G1-106A	021042	1.25	66.00	82.50				0.00
EDD-AIRE DG 52254M	18130E	2.70	66.00	177.00				0.00
				0.00				0.00
				0.00				0.00
				0.00				0.00
				0.00				0.00
Garmin GNS430W rack, conn.				0.00	97136453	6.60	63.00	409.50
Garmin GA35 GPS WAAS Ant				0.00	27187	0.50	64.00	32.00
EDD-AIRE H 8 L pm520136-1338				0.00	-96	4.60	63.00	289.80
United Altimeter 5834P-1				0.00	G210	1.00	66.00	66.00
				0.00				0.00
				0.00				0.00
				0.00				0.00
TOTAL		8.56	84.29	575.40		12.60	63.28	797.30

NET CHANGE	Weight 3.75	Arm 60.79	Moment 221.90
-------------------	--------------------	------------------	----------------------

PREVIOUS REPORT	DATE	Weight	Arm	Moment
	05/23/01			
Empty Weight & C.G.	% MAC N/A	2,232.72	60.37	179,413.80
CURRENT REPORT	DATE	Weight	Arm	Moment
	10/26/10			
Empty Weight & C.G.	% MAC N/A	2,235.87	60.34	179,655.70

SIGNED <i>Dwayne M. Jones</i>	DATE: 10-26-2010	AGENCY: JONES AVIONICS
-------------------------------	------------------	------------------------

Houston Southwest Airport
519 McKeever Rd Hangar E-5
Arcola Tx 77583

Beechcraft BONANZA®

AIRCRAFT BASIC EMPTY WEIGHT AND BALANCE

DATE 12-14-78 AIRCRAFT SERIAL NO. CE-835

MODEL F33A REGISTRATION NO. N2062P

STRUT POSITION - NOSE		MAIN		JACK POINT LOCATION
EXTENDED	<u>11.8</u>	<u>96</u>		FORWARD <u>83.1</u>
COMPRESSED	<u>13.1</u>	<u>97</u>		AFT <u>271.0</u>

PREPARED BY: *Gary [Signature]*

REACTION WHEEL - JACK POINTS	SCALE READING	TARE	NET WEIGHT	ARM	MOMENT
LEFT MAIN	1069	-	1069	-	
RIGHT MAIN	1090	-	1090	-	
SUB TOTAL	2159	-	2159	83.1	179413
NOSE OR TAIL	177	206	-29	271.0	-7859
TOTAL (AS WEIGHED)	2336	206	2130		171554

SPACE BELOW PROVIDED FOR ADDITIONS AND SUBTRACTIONS TO AS WEIGHED CONDITION

EMPTY WEIGHT			2130	80.5 171554
ENGINE OIL			26	- 638
UNUSABLE FUEL			36	79 2844
BASIC EMPTY WEIGHT	Actual		2192	79.9 175036

Supercold 2/2/79



WEIGHT AND BALANCE LOADING FORM

MODEL F33A SERIAL NO. CE-835 REG. NO. N2062P DATE 12-14-78

ITEM	WEIGHT	MOM/100		WEIGHT	MOM/100
BASIC EMPTY CONDITION	2192	1750			
FRONT SEAT OCCUPANTS	340	288			
3rd & 4th SEAT OCCUPANTS	340	412			
5th SEAT SEAT OCCUPANTS	-	-			
BAGGAGE	63	95			
BAGGAGE	-	-			
CARGO	-	-			
SUB TOTAL ZERO FUEL CONDITION	2935	2545			
FUEL LOADING (74 gal.)	444	333			
SUB TOTAL RAMP CONDITION	3379	2878			
*LESS FUEL FOR START, TAXI, AND TAKE-OFF	-12	-9			
SUB TOTAL TAKE-OFF CONDITION	3367	2869			
LESS FUEL TO DESTINATION (58 gal.)	-348	-261			
LANDING CONDITION	3019	2608			

*Fuel for start, taxi and take-off is normally 12 lbs. at an average mom/100 of 9

Beechcraft BONANZA®

EQUIPMENT LIST

MODEL F33A SERIAL NO. CK-835 REG. NO. N2062F DATE 12-14-78

STATUS OF EQUIPMENT: X = Installed in Airplane

O = Not Installed in Airplane

ITEM	WEIGHT	ARM
11. McCauley Constant Speed, 2-Blade Propeller		
o (a) McCauley 2A36C23 Hub with 84B-0 Blades	62	1
o (d) McCauley Propeller Spinner D3396	5	1
x (e) Woodward Governor D210680	3	10
14. McCauley Constant Speed, 3-Blade Propeller		
x (a) McCauley 3A32C76 Hub with 82NB-2 Blades	66	1
x (c) McCauley D3584 Spinner Assembly	4	1
x 102. Oil Radiator (d) Modine LE1502D (TCM 635996)	8	36
x 103. Induction Air Cleaner	1	10
x 113. Two 37-Gallon Optional Fuel Tanks Replacing Two Standard 22-Gallon Tanks	+11	75
115. Pressure Pump		
o (d) Airborne 442CW	3	41
x (f) Airborne 212CW	2	41
117. Fuel Pumps		
x (a) Dukes 1296-00-1	3	74
x (d) Engine Driven - TCM 638154-16A2	2	39
x 118. Starter (a) Prestolite MHJ-4003 (TCM 637847)	16	39
x 119. Starter Solenoid (a) Cutler-Hammer 6041H190	Negl.	-
201. Two Main Wheel-Brake Assemblies		
x (k) Cleveland 6.00-6, No. 20-69; Wheel Assembly No. 40-83A; Brake Assembly No. 30-54A	19	97

Beechcraft BONANZA®

EQUIPMENT LIST

MODEL F33A SERIAL NO. CE-835 REG. NO. N2062F DATE 12-14-78

STATUS OF EQUIPMENT: X = Installed in Airplane

O = Not Installed in Airplane

	ITEM	WEIGHT	ARM
X	202. Main Wheel Tires (f) Two 7.00-6, 6-ply Rating Tires with Tubes	24	97
X	205. One Nose Wheel 5.00-5 (f) Wheel Assembly, Cleveland No. 40-87	3	12
X	206. Nose Wheel Tire (a) One 5.00-5, 4-ply Rating Tire with Tube	7	12
O	211. Copilot Brakes	4	54
X	309. Alternator (a) 50 Amp. TCM P/N 641668 or Prestolite ALT-9422	12	11
O	(b) 100 Amp. TCM P/N 640789 or Prestolite ALV-9407	23	11
X	310. Battery (a) 24 Volt 17 Amp-Hr.	25	48
X	311. Landing Lights (a) Two General Electric 4596	2	9
X	312. Voltage Regulator (a) Beech P/N 60-389017-3	1	50
X	313. Anti-Collision Light, Upper (Beech Drawing 36-364030) (a) Grimes D7080A-1-24	2	182
X	314. Anti-Collision Light, Lower (Beech Drawing 36-364030) (a) Grimes D7080A-5-24	2	102
O	402. Dual Control Column (T-Type) (c) Beech 36-524021	+4	73

ISSUED 10-78

Page 2

Beechcraft BONANZA®

EQUIPMENT LIST

MODEL F33A SERIAL NO. CE-835 REG. NO. N2062P DATE 12-14-78

STATUS OF EQUIPMENT: X = Installed in Airplane

Ø = Not Installed in Airplane

ITEM	WEIGHT	ARM
X 411. Pilot's Operating Handbook and FAA Approved (c) Airplane Flight Manual, P/N 33-590009-13, Revision A2, (9-78) or later	-	-
* Ø 502. B. F. Goodrich Electro Thermal Propeller Deicing System per Beech Drawing 35-960080 AFMS P/N 36-590002-29	7	22
X 601. Stall Warning Indicator Installation (a) Safe-Flight (Beech Drawing 58-361013)	Negl.	-
X 602. Heated Pitot Head Installation (c) Beech Drawing 35-361159	1	74
X 603. Aileron Trimmer Control	1	73
X 607. Optional Seating (d) Fifth Seat	14	155
Ø 608. Oxygen System Installation (c) 49 cu. ft. per Beech Drawings 35-560001 and 35-560010-39	25	77
X 609. Emergency Static Air Source (a) Beech Drawing 35-324428	Negl.	-
* Ø 610. Landing Gear Safety System (b) Beech Drawing 35-364170 AFMS P/N 35-590110-13 Dated 9-77 or later required	3	104
Ø 612. Electrically Actuated Elevator Trim System (c) Installed per Beech Drawing 96-524031	3	200

ISSUED 10-78

Page 3

Beechcraft BONANZA®

EQUIPMENT LIST

MODEL F33A SERIAL NO. CE-835 REG. NO. N2062P DATE 12-14-78

STATUS OF EQUIPMENT: X = Installed in Airplane

0 = Not Installed in Airplane

	ITEM	WEIGHT	ARM
	617. Area Navigation Equipment (Installed per Applicable Beech Drawings)		
*	o (b) AFMS P/N 35-590118-13 for King KN-74 dated 10-76 or later required	-	-
*	o (c) AFMS P/N 33-590009-19 for Collins AN6-351 Dated 11-23-77 or later required	-	-
*	o (d) AFMS P/N 35-590118-43 for King KNS-80 Dated 8-78 or later required	-	-
*	o 619. Air Conditioning System (Refrigeration Type) AFMS P/N 35-590118-35 dated 10-76 or later required	70	66
	x Emergency Locator Transmitter	2	221
*FLIGHT MANUAL SUPPLEMENT REQUIRED			

ISSUED 10-78

Page 4

Beechcraft BONANZA®

EQUIPMENT LIST

MODEL F33A SERIAL NO. CE-835 REG. NO. N 2062P DATE 2/2/79

STATUS OF EQUIPMENT: X = Installed in Airplane

D = Not Installed in Airplane

ITEM	WEIGHT	ARM
<u>KING</u>		
X KMA-20 Audio Control	2.3	60.8
X KX-170B Transceiver	7.0	62.0
X KX-170B Transceiver	7.0	62.0
X KI-208 VOR/LOC Indicator	1.0	66.0
X KI-209 VOR/ILS Indicator	1.2	66.0
X KR-85 ADF Tuner	4.0	62.66
X KI-225 ADF Indicator	1.2	60.0
X KA-42B ADF Antenna	2.4	203.0
X KT-76A Transponder	3.0	63.0
X KA-40 Marker Lights	.3	58.5
X KN-65A DME R/T	7.6	182.0
X KA-58 DME Hold	.4	182.0
X KI-266 DME Indicator	.8	61.35
X KN-75 Glideslope Receiver	1.6	55.85
X KA-39 Power Converter	1.1	54.0
X KA-39 Power Converter	1.1	55.0
<u>EDO-AIRE MITCHELL</u>		
X 52D67 Attitude Gyro	2.7	61.33
X 52D54 Directional Gyro	2.9	61.33
X IC465 Roll Servo	2.3	115.2
X IC470 Pitch Servo	2.3	218.5
X IC469 Trim Servo	2.2	207.0
X IC515-10 Computer Amplifier	2.3	60.33
X IC725 Altitude Hold	1.8	187.5
X IC404 Controller	1.3	70.0
X IA526-1 Relay Box	.25	65.0
X IC709 Trim Amplifier	.7	192.0
X IC388M Radio Coupler	1.0	60.8

Beechcraft

AIRCRAFT BASIC EMPTY WEIGHT AND BALANCE

DATE 2/2/79 AIRCRAFT SERIAL NO. CE-835

MODEL F-33A REGISTRATION NO. N2062P

RUT POSITION - NOSE MAIN
 EXTENDED
 COMPRESSED

JACK POINT LOCATION
 FORWARD
 AFT

PREPARED BY: *Donna J. ...*

REACTION WHEEL - JACK POINTS	SCALE READING	TARE	NET WEIGHT	ARM	MOMENT
LEFT MAIN					
RIGHT MAIN					
SUB TOTAL					
NOSE OR TAIL					
TOTAL (AS WEIGHED)					

SPACE BELOW PROVIDED FOR ADDITIONS AND SUBTRACTIONS TO AS WEIGHED CONDITION

<p><i>SUPPERSEDED 9-9-80</i></p>					
EMPTY WEIGHT					
ENGINE OIL					
UNUSABLE FUEL					
BASIC EMPTY WEIGHT	Computed		<u>2254.32</u>	<u>80.69</u>	<u>181920.57</u>

Beechcraft BONANZA® EQUIPMENT LIST

MODEL F33A SERIAL NO. CE-835 REG. NO. N2062P DATE 2/2/79

STATUS OF EQUIPMENT: X = Installed in Airplane

D = Not Installed in Airplane

ITEM	WEIGHT	ARM
ANTENNAS	5.0	91
X B11-1 Nav/Com	2.1	139
X B-6 Com	.25	181
X DMNI-70 DME A	.25	60
X DMNI-70 Transponder	2.0	170.0
X AD-8 Marker	.6	56.0
X AD-9 Nav Coupler		
BENDIX		
X 3252013-1101 Encoding Altimeter	4.4	61.8
MISC.		
X Speaker	1.0	98
X Microphone and Headset	1.0	80
X Wiring, Plugs, etc.	2.0	60
X Silver Fuel Flow System	2.5	60

SECTION VII

SYSTEMS DESCRIPTION

TABLE OF CONTENTS

<i>SUBJECT</i>	<i>PAGE</i>
Airframe.....	7-5
Seating Arrangements.....	7-5
Flight Controls	
Control Surfaces.....	7-5
Control Column.....	7-5
Rudder Pedals.....	7-6
Trim Control.....	7-6
Electric Elevator Trim.....	7-6
Instrument Panel.....	7-6
Illustration (typical).....	7-7
Flight Instruments.....	7-8
Engine Instruments.....	7-8
Cluster Type Engine Instruments.....	7-8
Illustration.....	7-9
Manifold Pressure And Fuel Flow	
Indicator.....	7-9
Illustration.....	7-10, 7-11
Avionics Panel.....	7-12
Switches.....	7-12
Annunciator System	
Warning Light.....	7-12
Warning Light Control Switch.....	7-12A
Ground Control.....	7-12B
Wing Flaps.....	7-12B

SUBJECT	PAGE
Landing Gear	7-12C
Control Switch	7-12C
Position Indicators	7-12D
Safety Switches	7-12D
Circuit Breaker	7-13
Brakes	7-13
Manual Extension	7-14
Warning Horn (Serials CE-674 Thru CE-1306, Except CE-1301; CJ-129 Thru CJ-179)	7-14
Warning Horn and Gear Up Annunciator (Serials CE-1301, CE-1307 and after; CJ-180 and after)	7-14
Baggage Compartment	7-15
Seats, Seat Belts, And Shoulder Harnesses	
Seat Adjustments	7-16
Shoulder Harness Installation	7-16
Door, Windows And Exits	
Cabin Door	7-17
Openable Cabin Windows	7-18
Emergency Exits	7-18B
Control Locks	7-18C
Power Plant	7-18C
Engine Controls	
Throttle, Propeller, And Mixture	7-19
Cowling	7-19
Cowl Flaps	7-20
Induction System Icing	7-20
Lubrication System	7-20
Starter	7-21
Propeller	7-21
Fuel System	7-22
Fuel Cells	7-22
Fuel Quantity Indication System	7-22
Schematic	7-23
Auxillary Fuel Pump	7-24
Fuel Tank Selection	7-24
Fuel Required for Flight	7-24A

<i>SUBJECT</i>	<i>PAGE</i>
Electrical System.....	7-25
Battery.....	7-25
Alternator.....	7-25
External Power Receptacle.....	7-26
Lighting System	
Interior Lighting.....	7-26
Exterior Lighting.....	7-27
Environmental Systems	
Cabin Heating.....	7-28
Heater And Defroster Operation.....	7-28
Heating And Ventilating System Schematic.....	7-29
Cabin Ventilation.....	7-30
Cabin Fresh Air Outlets.....	7-30
Individual Overhead Fresh Air Outlets.....	7-30
Exhaust Vent.....	7-31
Oxygen System.....	7-31
Pitot And Static Systems	
Pitot System.....	7-31
Pitot Heat.....	7-32
Normal Static Air System.....	7-32
Emergency Static Air System.....	7-32
Instrument Pressure System.....	7-32
Stall Warning.....	7-33
Engine Break-in Information.....	7-33

AIRFRAME

The BEECHCRAFT Bonanza F33A is an all-metal, low-wing, single-engine airplane with retractable tricycle landing gear and conventional horizontal and vertical stabilizers.

SEATING ARRANGEMENTS

The Bonanza F33A is a 4- or 5-place airplane. In the standard configuration 4 seats are installed. A 5th seat is optional.

FLIGHT CONTROLS

CONTROL SURFACES

Control surfaces are operated through push-pull rods and conventional cable systems terminating in bellcranks.

CONTROL COLUMN

The throw-over type control column for elevator and aileron control can be placed in front of either front seat. Pull the T-handle latch at the back of the control arm and position the control wheel as desired. The aileron trimmer on the control column hub should be held until the column is repositioned.

RUDDER PEDALS

To adjust the rudder pedals, press the spring-loaded lever on the side of each pedal and move the pedal to its forward or aft position. The adjustment lever can also be used to place the right set of rudder pedals against the floor (when the copilot brakes are not installed) when not in use.

TRIM CONTROLS

Elevator trim is controlled by a handwheel located to the left of the throttle. An elevator tab position indicator dial is located above and to the left of the trim control.

The aileron trimmer on the control column hub displaces the ailerons. Displacement is maintained by cable loads imposed by the trimmer.

ELECTRIC ELEVATOR TRIM

The optional electric elevator trim system controls include the ON-OFF switch located on the instrument panel, a thumb switch on the control wheel and a circuit breaker on the right subpanel. The ON-OFF switch must be in the ON position to operate the system. The thumb switch is moved forward for nose down, aft for nose up, and when released returns to the center OFF position. When the system is not being electrically actuated, the manual trim control wheel may be used.

INSTRUMENT PANEL

The standard instrument panel of the Bonanza F33A consists of the floating instrument panel on the upper left portion, the engine instrument grouping on the center of the panel above the control wheel yoke, a radio grouping to the right of the engine instruments, and a subpanel which provides for a

compact circuit breaker group on the right side and switching panel on the left.

FLIGHT INSTRUMENTS

The floating instrument panel contains all flight instruments except the magnetic compass. On this panel are the airspeed indicator, gyro horizon, altimeter, turn coordinator, directional gyro, and vertical speed indicator, with provisions for an ADF indicator and a clock. Additional navigation equipment, such as dual omni indicators, can be mounted in the panel directly below the flight instrument grouping.

ENGINE INSTRUMENTS

The engine instruments, located on the center panel, include a fuel flow/manifold pressure indicator, an engine tachometer, a fuel quantity indicator for each side, and a cluster which includes an oil pressure indicator, an oil temperature indicator, a cylinder head temperature indicator, and an ammeter.

CLUSTER TYPE ENGINE INSTRUMENTS

The cluster type instruments, as shown in the accompanying illustration, are located in the center of the panel just below the fuel flow/manifold pressure indicator and tachometer. Included in the square cluster are the cylinder head temperature and oil temperature (both calibrated in degrees centigrade), ammeter, and oil pressure. A fuel quantity indicator is located on each side of the cluster, the left indicator for the left wing fuel and the right indicator for the right wing fuel.

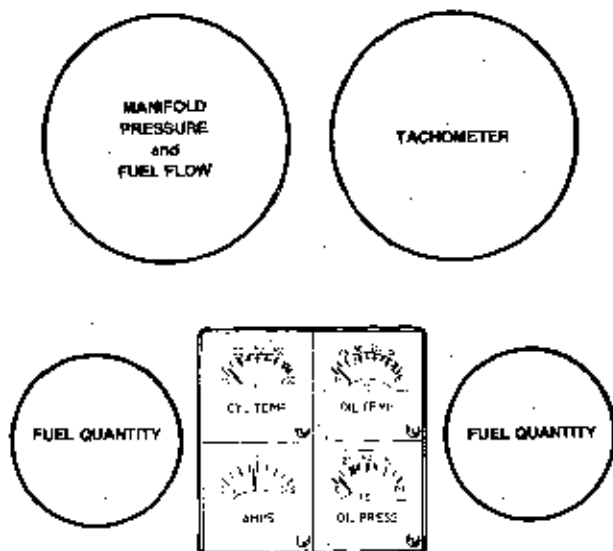

CLUSTER ARRANGEMENT

MANIFOLD PRESSURE AND FUEL FLOW INDICATOR

The manifold pressure portion of this instrument indicates the pressure in the engine manifold and is calibrated in inches of mercury. By observing the manifold pressure indication and adjusting the propeller and throttle controls, the power output of the engine can be adjusted. To avoid excessive cylinder pressures during cruise operations, observe the maximum recommended rpm and manifold pressure limits as indicated on the Manifold Pressure vs RPM graph in the PERFORMANCE Section.

*For Airplanes With Fuel Pressure Indicating Systems
(Serials CE-674 thru CE-928; CJ-129 thru CJ-155)*

The fuel flow portion of the indicator senses fuel pressure at the fuel distributor and is calibrated to indicate fuel flow in gallons per hour. The green arc indicates the normal fuel flow operating range while the red radials indicate the minimum and maximum allowable fuel pressures.

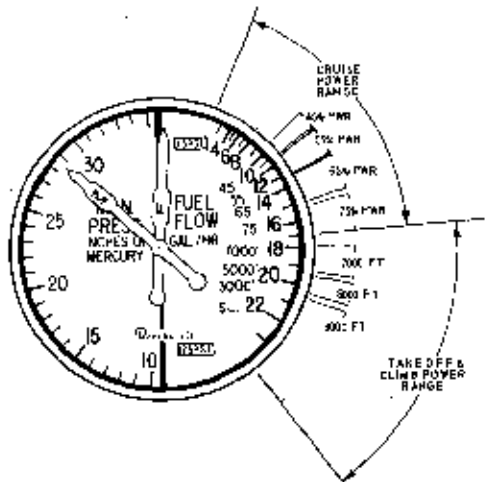

**MANIFOLD PRESSURE AND FUEL FLOW INDICATOR
(CE-674 THRU CE-928 AND CJ-129 THRU CJ-155)**

The higher end of the green arc includes a sawtooth segment to indicate the approximate fuel flow required for takeoff and climb at sea level, 3000, 5000 and 7000 feet. The pilot should use performance charts for the exact fuel flow requirements.

The lower end of the green arc includes a sawtooth segment labeled "% CRUISE POWER" which indicates the

approximate fuel flows for powers ranging from 45% to 75% of max continuous power. The lower fuel flow of each sawtooth corresponds to the cruise lean fuel flow while the higher fuel flow of each sawtooth corresponds to the best power fuel flow. When power is set in accordance with the cruise power setting tables in the PERFORMANCE section, these sawtooth markings provide approximate percent power information.

*For Airplanes With Fuel Flow Indicating Systems
(Serials CE-929 and after; CJ-156 and after)*

The fuel flow portion of the indicator is controlled electrically and indicates fuel flow in gallons per hour. A turbine meter installed in the fuel line rotates in proportion to the fuel flow. The speed of rotation is converted into an

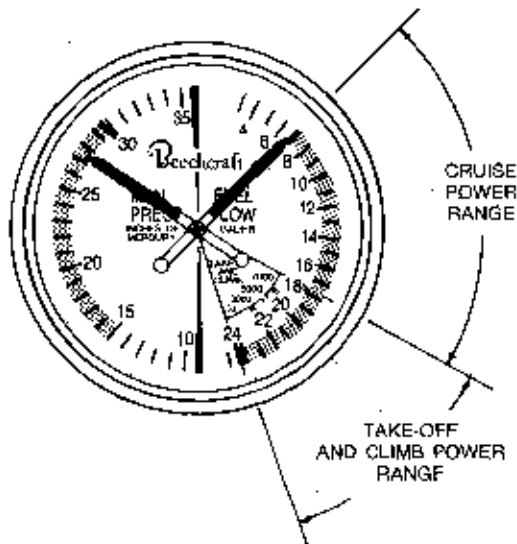

**MANIFOLD PRESSURE AND FUEL FLOW INDICATOR
(CE-929 AND AFTER AND CJ-156 AND AFTER)**

electrical signal which is then interpreted by the fuel flow indicator. The green arc indicates the normal operating range while the red radial indicates the maximum allowable fuel flow.

Fuel flow values at the higher end of the green arc are labeled "TAKE-OFF AND CLIMB" and indicate the approximate fuel flow required for takeoff and climb at sea level, 3000, 5000 and 7000 feet. The pilot should use these markings as a guide only and refer to the tables in the PERFORMANCE section for the exact fuel flow requirements.

AVIONICS PANEL

Tuning and selecting equipment for the radios, adjacent to the engine instrument grouping, is mounted in block form with switching on the left edge of the block and radio heads and tuning on the right.

SWITCHES

The magneto/start switch and switches for the battery, alternator, pitot heat, propeller deicer, and lights are located on the left end of the subpanel. Flap and tab position indicators, the cowl flap control, and the flap switch are near the center of the subpanel. On the right end of the subpanel are the circuit breakers, as well as the landing gear switch and landing gear position indicator lights. Attached to the lower center section of the subpanel are the powerplant controls and auxiliary fuel pump switch.

ANNUNCIATOR SYSTEM

WARNING LIGHTS (CE-674 thru CE-928 except CE-919, CE-923, CE-925 and CE-927; CJ-129 thru CJ-155)

A warning light placarded ALT OUT is located on the pilot's floating instrument panel below the flight instruments.

The warning light for the alternator will illuminate when the output from the alternator is nearly zero or when an alternator overvoltage occurs.

WARNING LIGHTS (CE-919, CE-923, CE-925, CE-927, CE-929 and after; CJ-156 and after)

Two warning lights, placarded ALT and STARTER ENERGIZED, are located on the pilot's floating instrument panel below the flight instruments.

The warning light for the alternator will illuminate when the output from the alternator is nearly zero or when an alternator overvoltage occurs.

The starter energized warning light will remain illuminated after starting if the starter relay remains engaged after starting.

On serials CE-1301, CE-1307 and after, and CJ-180 and after, a red GEAR UP annunciator is installed in the glareshield. The GEAR UP annunciator will flash when the gear warning horn sounds (any throttle setting less than 12 In. Hg with the landing gear retracted or full flaps with the landing gear retracted).

WARNING LIGHT CONTROL SWITCH

Located on the pilot's floating instrument panel near the warning light(s) is a switch placarded TEST-BRT-DIM-WARN LIGHTS. When the switch is held upward in the spring-loaded TEST position, the warning light(s) and the four landing gear position indicator lights will illuminate if none of the lamps require replacement. When released, the switch will return to the BRT position.

If the switch is in the bright (BRT) position, the warning light(s) and the landing gear position indicator lights will light at high intensity whenever they illuminate. This position should be selected during the daytime and at other times when high ambient light levels are present in the cabin.

The DIM position allows the lamps to illuminate to a lower intensity. This position is generally reserved for night operations. The GEAR UP and STARTER ENERGIZED annunciators (if installed), are the only annunciators that do not dim.

GROUND CONTROL

Steering is accomplished by use of the rudder pedals through a linkage arrangement which connects the nose gear to the rudder pedal shaft. Nose wheel straightening is accomplished by engagement of a roller with a track as the nose wheel is retracted. The steering link attaches to the steering mechanism on the nose gear with a swivel connection which permits the mechanism to disengage when the nose gear is retracted and operation of the rudder pedals will have no tendency to turn the nose wheel with the gear retracted.

The minimum wing tip turning radius, using full steering, one brake and partial power, is 26 feet 4 inches.

WING FLAPS

On airplanes prior to CE-816 and CJ-150 the wing flaps are controlled by a three-position switch, UP, OFF and DOWN, located in the subpanel, above the power quadrant. The switch must be pulled out of detent before it can be repositioned. A dial type indicator has markings for UP, 10°, 20° and DN. The indicator is located to the left of the control column.

Limit switches automatically turn off the electric motor when the flaps reach the extremes of travel. Intermediate flap positions can be obtained by placing the switch in the OFF position as the flaps reach the desired position during flap extension or retraction.

On airplanes CE-816 and after and CJ-150 and after, the wing flaps have three positions; UP (0°), APPROACH (15°), and DOWN (30°), with no intermediate positions. A flap position indicator and a control switch are located on the subpanel, above the power quadrant. The switch must be pulled out of a detent to change the flap position.

LANDING GEAR

The landing gear is operated through adjustable linkage connected to an actuator assembly mounted beneath the front seats. The actuator assembly is driven by an electric motor. The landing gear may be electrically retracted and extended, and may be lowered manually.

CONTROL SWITCH

The landing gear is controlled by a two-position switch on the right side of the subpanel. The switch handle must be pulled out of the safety detent before it can be moved to the opposite position.

NOTE

On S/N CE-1301, CE-1307 and after, and CJ-180 and after, the landing gear will not retract unless the throttle is in a position corresponding to approximately 17 in. Hg manifold pressure or above.

POSITION INDICATORS

The landing gear position indicator lights are located adjacent to the landing gear switch handle. Three green lights, one for each gear, are illuminated whenever the landing gears are down and locked. The red light illuminates any time one or all of the landing gears are in transit or in any intermediate position. All of the lights will be out when the gear is up.

Testing of the landing gear position indicator lamps, as well as selection of either bright or dim illumination intensity, is accomplished with the warning light control switch located on the pilot's floating instrument panel.

SAFETY SWITCHES

Inadvertent retraction of the landing gear on the ground is prevented by compressing the two main strut safety switches (or by retarding the throttle below approximately 17 in. Hg manifold pressure - CE-1301, CE-1307 and after, and CJ-180 and after).

WARNING

Never rely on the safety switches to keep the gear down during taxi or on takeoff, landing roll, or in a static position. Always make certain that the landing gear switch is in the down position during these operations.

NOTE

On serials CE-1301, CE-1307 and after, and CJ-180 and after, the throttle switch which deactivates the landing gear control circuit will always activate at the same throttle position. The resultant manifold absolute pressure is dependent upon altitude and rpm.

CIRCUIT BREAKER

The landing gear circuit breaker is located on the right sub-panel. This circuit breaker is a pull-and-reset type breaker. The breaker will pop out under overload conditions.

BRAKES

The brakes on the main landing gear wheels are operated by applying toe pressure to the top of the rudder pedals. The parking brake T-handle control is located just left of the elevator tab wheel on the pilot's subpanel. To set the parking brakes, pull the control in and depress each toe pedal until firm. Push the control in to release the brakes.

NOTE

The parking brake should be left off and wheel chocks installed if the airplane is to be left unattended. Changes in ambient temperature can cause the brakes to release or to exert excessive pressures.

On serials CE-674 thru CE-838, and CJ-129 thru CJ-149 with shuttle valves installed only the pilot's brake pedals can be used in conjunction with the parking brake system to set the parking brake.

CAUTION

On serials CE-674 thru CE-838, and CJ-129 thru CJ-149 with shuttle valves installed, continuous brake application of either the pilot's or copilot's brake pedals, in conjunction with an overriding pumping action from the opposite brake pedals could result in the loss of braking action on the side which continuous pressure is being applied.

MANUAL EXTENSION

The landing gear can be manually extended by operating a handcrank at the rear of the front seats. This procedure is described in the EMERGENCY PROCEDURES Section.

WARNING HORN (SERIALS CE-674 THRU CE-1306, EXCEPT CE-1301; CJ-129 THRU CJ-179)

With the landing gear retracted, if the throttle is retarded below approximately 12 in. Hg manifold pressure, a warning horn will sound intermittently.

NOTE

The switch which activates the warning horn is operated by the throttle; thus the horn will always sound at the same throttle position. The resultant manifold absolute pressure is dependent on the altitude and rpm.

WARNING HORN AND GEAR UP ANNUNCIATOR (SERIALS CE-1301, CE-1307 AND AFTER; CJ-180 AND AFTER)

With the landing gear retracted, a warning horn will sound intermittently and the gear up annunciator will flash if the throttle is retarded below approximately 12 in. Hg manifold pressure or if the flaps are fully extended.

NOTE

The switch which activates the warning horn/GEAR UP annunciator is operated by the throttle; thus the horn and GEAR UP annunciator will always activate at the same throttle position. The resultant manifold absolute pressure is dependent on altitude and rpm.

BAGGAGE COMPARTMENT

The baggage compartment is accessible through the baggage door on the right side of the fuselage. This area extends aft of the pilot and copilot seats to the rear bulkhead. Because of structural limitations, this area is divided into two sections, each having a different weight limitation. Loading within the baggage compartment must be in accordance with the data in the WEIGHT AND BALANCE Section. All baggage must be secured with a Beech approved cargo net.

WARNING

Unless authorized by applicable Department of Transportation regulations, do not carry hazardous material anywhere in the airplane.

Do not carry children in the baggage compartment unless secured in a seat.

SEATS, SEAT BELTS, AND SHOULDER HARNESSSES.

SEAT ADJUSTMENTS

To adjust any of the four standard seats forward or aft, pull up on the release bar below the seat and slide the seat to the desired position. The seat backs of all standard seats can be placed in any of four positions by operating a release lever on the inboard side of each seat. An option is available that provides for the seat backs on the copilot, 3rd and 4th place seats to be placed in any position from vertical to fully reclined. Outboard armrests for all standard seats are built into the cabin sidewalls. Center armrests can be elevated or positioned flush with the seat cushions. The 3rd- and 4th-place chairs are equipped with a locking back to accommodate the shoulder harness, and the seat back can be folded over for access by rotating the red handle located on the lower inboard side of the seat back. The optional 5th seat can be folded up to provide additional floor space.

SHOULDER HARNESS INSTALLATION

The shoulder harness is a standard installation for all seats and should be used with the seats in the upright position. The spring loading at the inertia reel keeps the harness snug but will allow normal movement during flight operations. The inertia reel is designed with a locking device that will secure the harness in the event of sudden forward movement or an impact action.

The strap is worn over the shoulder and down across the body, where it is fastened by a metal loop into the seat belt buckle. For the pilot seats, the harness strap is contained in an inertia reel attached to the side canopy structure of the cockpit. The inertia reel is covered with an escutcheon and the strap runs up from the reel location to a looped fitting attached to the window frame just aft of the pilot seats. For

the third and fourth passenger seats, the inertia reel is attached into the seat back structure and is covered with the seat back upholstery. The strap runs up the seat back and over the outboard corner of the seat back. For the 5th passenger seat, the strap is contained in an inertia reel attached to the upper fuselage side structure, just aft of the seat back and is covered with an escutcheon.

NOTE

The seat belt is independent of the shoulder harness, but the outboard seat belt and the shoulder harness must be connected for stowage when the seat is not occupied.

DOOR, WINDOWS AND EXITS

CABIN DOOR

The outside cabin door handle is spring loaded to fit into a recess in the door to create a flat aerodynamically clean surface. To open the door from the outside, lift the handle from its recess and pull until the door opens.

To close the cabin door from the inside, observe that the door handle is in the open position. In this position, the latch handle is free to move approximately one inch in either direction before engagement of the locking mechanism. Then grasp the door and firmly pull the door closed. Rotate the door handle fully counterclockwise into the locked position. Observe that the door handle indicator is in the CLOSED position (serials CE-1301, CE-1307 and after; CJ-180 and after). When the door is properly locked, the door latch handle is free to move approximately one inch in either direction.

NOTE

When checking the door latch handle, do not move it far enough to engage the door latch release mechanism.

Press firmly outward at the top rear corner of the door. If any movement of the door is detected, completely open the door and close again following the above instructions.

To open the door from the inside, depress the lock button and rotate the handle clockwise.

OPENABLE CABIN WINDOWS

NOTE

Windows are to be closed before and during flight.

Prior to CE-929 except CE-919, CE-923, CE-925 and CE-927; Prior to CJ-156:

To Open Window For Ventilation (Only On Ground):

Release latch front of bar, pull bar at the bottom of the window out and upward. Window will open approximately two inches.

To Close Window:

Pull inward and down on the bar at the bottom of the window. Resistance will be felt as the bar moves downward. Continue moving bar downward to its lowest position. Check that bar is locked by the latch.

NOTE

While closing window, ascertain that the emergency release pin (which allows the window to open fully for emergency exit) is securely in place.

Serials CE-919, CE-923, CE-925, CE-927, CE-929 thru CE-983:

A plastic-covered multipurpose latch on each openable window is used to provide partial opening of the window for ventilation during ground operations, and also quick unlatching for emergency egress.

To Open Window For Ventilation (Only On Ground):

NOTE

Red handle for emergency exit only.

1. Lift thumb catch (window will release).
2. Push up and outward until mechanism clicks into detent.

To Close Window:

— Pull inward and down until locked. (Listen for detent.)

Serials CE-984 and after; CJ-156 and after:

To Open Window For Ventilation (Only On Ground):

NOTE

Red handle for emergency exit only.

1. Rotate lock handle to UNLOCKED position.
2. Lift thumb catch (window will release).
3. Push latch up and outward to over-center position.

To Close Window:

1. Pull latch inward and push down until locked (listen for detent).
2. Rotate lock handle to LOCKED position.

EMERGENCY EXITS

To open the emergency exit provided by the openable window on each side of the cabin:

Prior to CE-929, Except CE-919, CE-923, CE-925, and CE-927; Prior to CJ-156:

1. Lift the latch.
2. Pull out the emergency release pin and push the window out.

The above procedure is described on a placard installed below the left and right openable windows.

Serials CE-919, CE-923, CE-925, CE-927, CE-929 and after; CJ-156 and after:

1. Remove cover as indicated by placard in the center of the Ventilation/Emergency Exit latch.
2. Rotate handle up as indicated by placard, breaking safety wire, and push window out.

NOTE

Anytime the window has been opened by breaking the safety wire on the red emergency latch, the window must be reattached and wired by a qualified mechanic using QQ-W-343, Type S, .020 diameter copper wire prior to further airplane operation.

CONTROL LOCKS

To Install The Control Locks:

1. Rotate control wheel and move column so the hole in the bracket and the column align to accept pin.
2. Push the control column lock pin through the hole provided in the control column hanger and into the hole in the control column tube assembly.
3. Ensure positive retention of the lock pin by positioning the attached red plate on top of the throttle and propeller controls.

WARNING

Before starting engine, remove the lock by reversing the above procedure.

POWER PLANT

The BEECHCRAFT F33A Bonanza is powered by a Continental IO-520-BA or IO-520-BB six-cylinder, horizontally opposed, fuel-injected engine rated at 285 horsepower.

ENGINE CONTROLS

THROTTLE, PROPELLER, AND MIXTURE

The push-pull throttle, propeller, and mixture controls are located on the control console below the center of the upper subpanel. These controls are released for repositioning by pushing a button on the knob. With the button extended, fine adjustments are accomplished by rotating the knob, clockwise to increase and counterclockwise to decrease.

COWLING

The Bonanza F33A is equipped with Hartwell latch mechanisms on the right and left upper engine cowling for quick and easy access to the engine compartments without the aid of tools. Each cowl latch is locked and released by a single recessed handle located in the lower cowling panel on each side of the engine. To close the cowling requires only to lower the cowling to the closed position with the handle in the prelatch position. The handle has three positions: flush with the fuselage - latched; held fully forward - unlatched (open cowling); approximately 90° to the fuselage - prelatch (ready to close cowl). An audible click denotes the bayonet fittings, located forward and aft on the upper cowl, sliding into the latch safety catch. The cowl is locked by moving the latch handle to the full recessed position. The security of the forward latches can be checked by pulling out on the check tab attached to the lower forward edge of the upper cowling. If the cowling can be moved after latching, open the cowling, check the latch alignment and re-latch.

COWL FLAPS

The push-to-close, pull-to-open cowl flap control is located above and to the left of the control console on the subpanel. Except in extremely low temperatures, the cowl flaps should be open during ground operation, takeoff, and as required during flight.

INDUCTION SYSTEM ICING

The possibility of induction system icing is reduced by the non-icing characteristics of the Bonanza's fuel injected engine and automatic alternate air source. Under certain conditions, however, impact ice can form at several points in the induction system. If the air intake or filter becomes clogged with ice, a spring-loaded door in the air intake duct will open automatically and the induction system will operate on alternate air. If the alternate air source door becomes frozen in the closed position, a pull-and-release T-handle is provided to force the door open.

LUBRICATION SYSTEM

The engine oil system is the full-pressure, wet sump type and has a 12-quart capacity. Oil operating temperatures are controlled by an automatic thermostat bypass control. The bypass control will limit oil flow through the oil cooler when operating temperatures are below normal and will permit the oil to bypass the cooler if it should become blocked.

STARTER

The starter is relay controlled and is actuated by a rotary type, momentary-on switch incorporated in the magneto/start switch. To energize the starter circuit, rotate the magneto/start switch beyond the BOTH position to START. After starting, release the switch to the BOTH position.

The warning light placarded STARTER ENERGIZED (CE-919, CE-923, CE-925, CE-927, CE-929 and after; CJ-156 and after) will illuminate whenever electrical power is being supplied to the starter. If the light remains illuminated after starting, the starter relay has remained engaged and loss of electrical power may result. The battery and alternator switches should be turned off if the light remains illuminated after starting. If the light does not illuminate during starting, the indicator system is inoperative and the ammeter should be monitored to ensure that the starter does not remain energized after starting. The starter energized warning light can be tested with the TEST-BRT-DIM-WARN LIGHTS switch adjacent to the warning lights on the floating instrument panel.

PROPELLER

An optional 80"-diameter, three-blade propeller is also available. The pitch setting at the 30-inch station is 13.3° low and 29.0° high pitch.

Installed as standard equipment on the Bonanza is a constant speed, variable pitch, 84"-diameter propeller with two aluminum alloy blades. The pitch setting at the 30-inch station is 13.3° low and 29.2° high pitch.

Propeller rpm is controlled by a governor which regulates hydraulic oil pressure to the hub. A push-pull knob on the

control console allows the pilot to select the governor's rpm range.

If oil pressure is lost, the propeller will go to the full high rpm position. This is because propeller low rpm is obtained by governor boosted engine oil pressure working against the centrifugal twisting moment of the blades.

FUEL SYSTEM

The airplane is designed for operation on 100/130 grade (green) aviation gasoline. However, the use of 100LL (blue) is preferred.

FUEL CELLS

On CE-674 thru CE-883, and CJ-129 thru CJ-155 either the 44-gallon usable (50-gallon capacity) or 74-gallon usable (80-gallon capacity) fuel system is available. The 74-gallon usable (80-gallon capacity) system only is available on CE-884 and after, and CJ-156 and after. The fuel system consists of a rubber fuel cell in each wing leading edge with a flush type filler cap. A visual measuring tab is attached to the filler neck of the optional system. The bottom of the tab indicates 27 gallons of usable fuel and the detent on the tab indicates 32 gallons of usable fuel in the tank. The engine driven fuel injector pump delivers approximately 10 gallons of excess fuel per hour, which bypasses the fuel control and returns to the tank being used. Three fuel drains are provided, one in each fuel sump on the underside of each wing and one in the fuel selector valve inboard of the left wing root. These points should be drained daily before the first flight.

FUEL QUANTITY INDICATION SYSTEM

Fuel quantity is measured by float operated sensors, located in each wing tank system. These transmit electrical signals to the individual indicators, which indicate fuel remaining in the tank. There are sensors in each wing tank system connected to the individual wing tank indicator.

AUXILIARY FUEL PUMP

The electric auxiliary fuel pump is controlled by an ON-OFF toggle switch on the control console and provides pressure for starting and emergency operation. Immediately after starting, the auxiliary fuel pump can be used to purge the system of vapor caused by an extremely high ambient temperature or a start with the engine hot. The auxiliary fuel pump provides for near maximum engine fuel requirements, should the engine driven pump fail.

FUEL TANK SELECTION

The fuel selector valve handle is located forward and to the left of the pilot's seat. Takeoffs and landings should be made using the tank that is more nearly full.

If the engine stops because of insufficient fuel, refer to the EMERGENCY PROCEDURES Section for the Air Start procedures.

FUEL REQUIRED FOR FLIGHT

It is the pilot's responsibility to ascertain that the fuel quantity indicators are functioning and maintaining a reasonable degree of accuracy, and to be certain of ample fuel for a flight. Takeoff is prohibited if the fuel quantity indicators do not indicate above the yellow arc. An inaccurate indicator could give an erroneous indication of fuel quantity. A minimum of 13 gallons of fuel is required in each tank before takeoff. The caps should be removed and fuel quantity checked to give the pilot an indication of fuel on board. The airplane must be approximately level for visual inspection of the tank. If it is not certain that at least 13 gallons are in each tank, fuel shall be added so that the amount of fuel will be not less than 13 gallons per tank at takeoff. Plan for an ample margin of fuel for any flight.

ELECTRICAL SYSTEM

The system circuitry is the single-wire, ground-return type, with the airplane structure used as the ground return. The battery ON-OFF switch, the alternator ON-OFF switch and the magneto/start switch are located on the left subpanel. The circuit breaker panel is located on the right subpanel and contains circuit breakers for the various electrical systems. Some switch-type circuit breakers are located on the left subpanel.

BATTERY

28-VOLT SYSTEM (CE-748, CE-772 AND AFTER, CJ-149 AND AFTER)

A 15.5 ampere-hour, 24-volt battery is located on the right forward side of the firewall. Battery servicing procedures are described in the HANDLING, SERVICING, and MAINTENANCE Section.

14-VOLT SYSTEM (CJ-129 THRU CJ-148, CE-674 THRU CE-771 EXCEPT CE-748)

A 35-ampere-hour, 12-volt battery is located on the right forward side of the firewall. Battery servicing procedures are described in the HANDLING, SERVICING and MAINTENANCE Section.

ALTERNATOR

28-VOLT SYSTEM (CE-748, CE-772 AND AFTER, CJ-149 AND AFTER)

The airplane is equipped with a 50-, 60-, or 100-ampere, gear-driven alternator. The alternators are designed to maintain approximately 50-, 60-, or 100-amperes output respectively at 1700 rpm to provide airplane electrical power.

**14-VOLT SYSTEM (CJ-129 THRU CJ-148, CE-674 THRU
CE-771 EXCEPT CE-748)**

A 70-ampere, 12-volt, gear-driven alternator is standard equipment. The alternator is designed to maintain approximately 70-ampere output at 1700 rpm, to provide airplane electrical power.

A transistorized electronic voltage regulator adjusts alternator output to the required electrical load, including battery recharge. Charging or discharging of the battery is indicated by the ammeter. A zero reading, which is normal for cruising flight, indicates that the battery is fully charged and that alternator output has been adjusted by the voltage regulator to balance the load of the electrical equipment in use.

The alternator-out warning light can be tested with the warning test switch on the instrument panel adjacent to the light. If an alternator failure occurs the light will illuminate.

EXTERNAL POWER RECEPTACLE

The external power receptacle accepts a standard AN-type plug. Before connecting an external power unit, verify that a battery is installed. The battery switch should be ON, and alternator and avionics equipment OFF.

NOTE

A negative ground external power source is required.

If the external power unit does not have a standard AN type plug, check the polarity and connect the positive lead from the external power source to the positive battery terminal and the negative lead to the negative battery terminal.

LIGHTING SYSTEM

INTERIOR LIGHTING

Lighting for the instrument panel is controlled by thumb-rotated, disc-type rheostats, located on the pilot's subpanel to the left of the control column. The first rheostat is labeled

RADIO and ENG and controls the lighting of the avionics panel and the multiple readout engine instrument. The second rheostat, labeled INST, is optional and controls the lighting for the flight instruments and the instrument pressure gage.

On the lower subpanel are two more lighting rheostats. The first, labeled SUB, controls the intensity of the complete subpanel lighting. The second rheostat is labeled FLOOD and controls the glareshield lighting, which illuminates the full upper panel.

The cabin dome light is operated by an ON-OFF switch adjacent to the light. The optional reading lights above the rear seats have individual switches at the lights. The optional map light has a press-type switch on the control wheel. The OAT, map, and compass lights are controlled by a push-on, push-off switch located adjacent to the OAT or on the control wheel.

EXTERIOR LIGHTING

The switches for all of the exterior lights are located on the pilot's left subpanel. Each switch is a circuit-breaker-type switch, which will open if it becomes overloaded or shorted.

The exterior lights consist of navigation lights on the wing tips and tail cone, a landing light in the fuselage nose section, and a taxi light attached to the nose strut. The landing light can be used for approach and taxiing. For longer battery and lamp life, use the landing light and the taxi light sparingly; avoid prolonged operation which could cause overheating

during ground maneuvering.

NOTE

Particularly at night, reflections from anti-collision lights on clouds, dense haze or dust can produce optical illusions and intense vertigo. Such lights, when installed, should be turned off before entering an overcast; their use may not be advisable under instrument or limited VFR conditions.

ENVIRONMENTAL SYSTEMS

CABIN HEATING

A heater muffler on the right exhaust stack provides for heated air to five outlets in the forward and aft areas of the cabin. The two forward outlets are located above and forward of each set of rudder pedals. The two aft outlets are installed behind the right front seat and the right rear seat. The fifth outlet provides heated air for windshield defrosting.

In flight, ram air enters an intake on the right side of the nose, passes through the heater muffler, then into a mixer valve on the forward side of the firewall. In the mixer valve, the heated air is combined with a controlled quantity of unheated ram air picked up at an intake at the rear engine baffle. Air of the desired temperature is then ducted from the mixer valve to the outlets in the cabin.

HEATER AND DEFROSTER OPERATION

The heater controls are located on the lower left pilot's subpanel. To obtain heated air to the cabin outlets, pull the

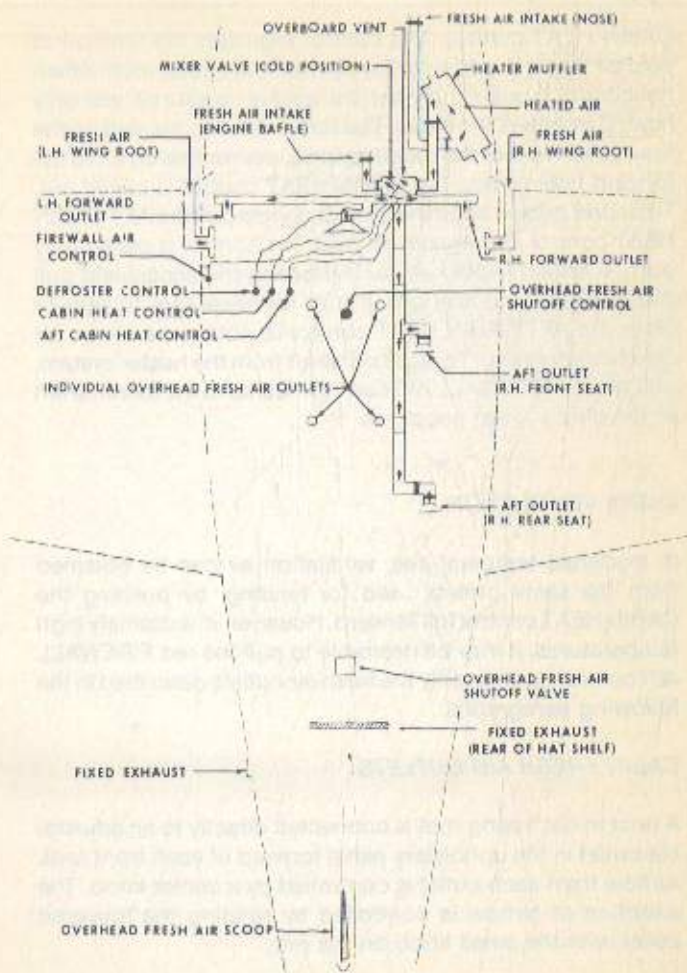

HEATING AND VENTILATING SYSTEM

CABIN HEAT control. The control regulates the amount of cold air that is mixed with the air from the heater muff. When the control is pulled fully out, the cold air is shut off and only heated air enters the cabin. The forward vents, located on the firewall forward of the rudder pedals, deliver heated air to the forward cabin when the CABIN HEAT control is pulled out. To deliver heated air to the aft seat outlets pull the AFT CABIN HEAT control. For maximum heat, the control is pulled fully out. To obtain heated air for defrosting the windshield pull the DEFROST control out. It may be necessary to vary or close the AFT CABIN HEAT control to obtain maximum air flow for defrosting. To close off all air from the heater system, pull the red FIREWALL AIR control located to the extreme left of the pilot's lower subpanel.

CABIN VENTILATION

In moderate temperatures, ventilation air can be obtained from the same outlets used for heating, by pushing the CABIN HEAT control full forward. However, in extremely high temperatures, it may be desirable to pull the red FIREWALL AIR control and use only the fresh air outlets described in the following paragraphs.

CABIN FRESH AIR OUTLETS

A duct in each wing root is connected directly to an adjustable outlet in the upholstery panel forward of each front seat. Airflow from each outlet is controlled by a center knob. The direction of airflow is controlled by rotating the louvered cover with the small knob on the rim.

Individual Overhead Fresh Air Outlets

Fresh ram air from the air intake on the upper side of the aft fuselage is ducted to individual outlets above each seat.

including the optional 5th seat. Each outlet can be positioned to direct the flow of air as desired. The volume of incoming air can be regulated by rotating the outlet. A system shutoff valve is installed in the duct between the overhead fresh air scoop and the individual fresh air outlets. The valve is operated by turning a knob on the overhead panel.

EXHAUST VENT

A fixed exhaust vent is located in the aft cabin.

OXYGEN SYSTEM

The oxygen cylinder is located beneath the cover under the front seats. The system is available with either 4 or 5 outlets and with a 49-cu-ft oxygen cylinder. Supply of oxygen to the system is controlled by a shut-off valve on the oxygen console. The pressure gage indicates the supply of oxygen available (1850 psig is nominal pressure for a full supply in the cylinder).

The system regulator is altitude-compensated to provide a varying flow of oxygen with altitude. Flow is varied automatically from 0.5 liters per minute at 5,000 feet to 2.8 liters per minute at 25,000 feet. The use of oxygen is recommended to be in accordance with current FAR operating rules.

PITOT AND STATIC SYSTEMS

PITOT SYSTEM

The pitot system provides a source of impact air for operation of the airspeed indicator. The pitot mast is located on the leading edge of the left wing.

PITOT HEAT

The pitot mast is provided with an electric heating element which is turned on and off with a switch on the instrument panel. The switch should be ON when flying in visible moisture. It is not advisable to operate the pitot heating element on the ground except for testing or for short intervals of time to remove ice or snow.

NORMAL STATIC AIR SYSTEM

The normal static system provides a source of static air to the flight instruments through a flush static fitting on each side of the airplane fuselage. Aft of the rear closure bulkhead (rear seat panel) is a drain plug, located at the low point of the normal static system. It is provided in order to drain moisture accumulations from the system. The closure bulkhead is held in place with Velcro and may be removed by pulling forward. The drain plug should be removed and the moisture drained from the clear plastic line every 100 hours and after exposure to visible moisture, either in the air or on the ground.

EMERGENCY STATIC AIR SYSTEM

An emergency static air source may be installed to provide air for instrument operation should the static ports become blocked. Refer to the EMERGENCY PROCEDURES Section for procedures describing how and when to use this system.

INSTRUMENT PRESSURE SYSTEM

Instrument pressure is supplied by an engine driven pressure pump. Pressure is controlled by an adjustable pressure regulator on the forward side of the firewall.

A gage located in the upper right corner of the instrument

panel indicates the system pressure in inches of mercury. The pressure should be maintained within the green arc for proper operation of the pressure operated instruments.

STALL WARNING

A stall warning horn on the forward side of the instrument panel sounds a warning signal (the battery switch must be ON for serials CE-748, CE-772 and after) as the airplane approaches a stall condition. The horn is triggered by a sensing vane on the leading edge of the left wing, and is effective at all altitudes. Irregular and intermittent at first, the warning signal will become steady as the airplane approaches a complete stall.

ENGINE BREAK-IN INFORMATION

Use a straight mineral oil, as recommended by the engine manufacturer, throughout the break-in period. Drain the initial oil at 20 to 30 hours. Replace with new mineral oil, which is to be used until oil consumption stabilizes (usually a total of 50 hours).

Drain and replace the engine oil as recommended in the HANDLING, SERVICING, and MAINTENANCE Section. If operating conditions are unusually dusty and dirty, more frequent oil changes may be necessary. Oil changes are more critical during the engine break-in period than at any other time.

Use full throttle at recommended rpm for every takeoff and maintain until at least 400 feet AGL. Then reduce as necessary for cruise climb or cruise. Maintain the highest power recommended for cruise operation during the break-in period, avoiding altitudes above 8000 feet. Interrupt cruise power every 30 minutes by smoothly advancing to take-off power settings for about 30 seconds, then returning to cruise

power setting. Avoid long power-off descents, especially during the break-in period. During descent, maintain sufficient power to maintain cylinder head temperatures in the green arc. Minimize ground operation time, especially during warm weather. During the break-in period, avoid engine idling in excess of 15 minutes, especially in high ambient temperatures.

SECTION VIII

HANDLING, SERVICING AND MAINTENANCE

TABLE OF CONTENTS

<i>SUBJECT</i>	<i>PAGE</i>
Introduction.....	8-5
Publications.....	8-6
Airplane Inspection Periods.....	8-6A
Preventative Maintenance That May Be Accomplished By A Certificated Pilot.....	8-7
Alterations or Repairs to Airplane.....	8-7
Ground Handling.....	8-8
Towing.....	8-8
Parking.....	8-9
Tie-Down.....	8-9
Main Wheel Jacking.....	8-10
Prolonged Out of Service Care.....	8-10
Flyable Storage - 7 to 30 Days	
Mooring.....	8-11
Engine Preparation for Storage.....	8-11
Fuel Cells.....	8-11
Flight Control Surfaces.....	8-11
Grounding.....	8-12
Pitot Tube.....	8-12
Windshield and Windows.....	8-12
During Flyable Storage.....	8-12
Preparation for Service.....	8-13

SUBJECT	PAGE
External Power	8-13
Checking Electrical Equipment	8-14
Servicing	
Fuel System	8-14
Fuel Cells	8-14
Fuel Drains	8-15
Fuel Strainers	8-15
Oil System	8-16
Battery	8-17
Recharging Battery Using External Power	8-17
Tires	8-18
Shock Struts	8-18
Shimmy Damper	8-20
Brakes	8-20
Induction Air Filter	8-21
Instrument Pressure System	8-21
Propeller	8-21
Propeller Blade Bearing Lubrication	8-22
Oxygen System	8-22
Oxygen Cylinder Retesting	8-23
Minor Maintenance	
Rubber Seals	8-24
Alternator	8-24
Magnetos	8-25
Cleaning	
Exterior Painted Surfaces	8-25
Windshield and Windows	8-26B
Engine	8-27
Interior	8-27

<i>SUBJECT</i>	<i>PAGE</i>
Lubrication Points (Diagrams).....	8-29
Recommended Servicing Schedule.....	8-36
Consumable Materials.....	8-40
Approved Engine Oils.....	8-42
Bulb Replacement Guide.....	8-44
Overhaul or Replacement Schedule.....	8-45

INTRODUCTION

The purpose of this section is to outline the requirements for maintaining the Bonanza F33A in a condition equal to that of its original manufacture. This information sets the time frequency intervals at which the airplane should be taken to a BEEHCRAFT Aero Center, Aviation Center, International Distributor or International Dealer for periodic servicing or preventive maintenance.

The Federal Aviation Regulations place the responsibility for the maintenance of this airplane on the owner and operator, who must ensure that all maintenance is done by qualified mechanics in conformity with all airworthiness requirements established for this airplane.

All limits, procedures, safety practices, time limits, servicing and maintenance requirements contained in this handbook are considered mandatory.

Authorized BEEHCRAFT Aero Centers, Aviation Centers, International Distributors and International Dealers can provide recommended modification, service, and operating procedures issued by both the FAA and Beech Aircraft Corporation, which are designed to get maximum utility and safety from the airplane.

If a question should arise concerning the care of the Bonanza F33A, it is important to include the airplane serial number in any correspondence. The serial number appears on the model designation placard attached to the right side of the fuselage just under the baggage door.

PUBLICATIONS

The following publications are available through BEECHCRAFT Aero Centers, Aviation Centers, International Distributors or International Dealers:

1. Shop Manual
2. Parts Catalog
3. Service Instructions
4. Various Inspection Forms
5. Wiring Diagram Manual

NOTE

Neither Service Publications, Reissues nor Revisions are automatically provided to the holder of this handbook. For information on how to obtain "Revision Service" applicable to this handbook, consult a BEECHCRAFT Aero Center, Aviation Center, International Distributor or International Dealer, or refer to the latest revision of BEECHCRAFT Service Instructions No. 0250-010.

AIRPLANE INSPECTION PERIODS

1. FAA Required Annual Inspections.
2. BEECHCRAFT Recommended Inspection Guide.
3. Continuing Care Inspection Guide.
4. See "Recommended Servicing Schedule" and "Overhaul or Replacement Schedule" for further inspection schedules.

NOTE

In event of emergency gear or flap extension at speeds above the respective normal extension speeds and before the next flight, inspect gear retract rods, gear doors and flaps for damage or distortion.

PREVENTATIVE MAINTENANCE THAT MAY BE ACCOMPLISHED BY A CERTIFICATED PILOT

1. A certificated pilot may perform limited maintenance. Refer to FAR Part 43 for the items which may be accomplished.

To ensure proper procedures are followed, obtain a BEECHCRAFT Shop Manual before performing preventative maintenance.

2. All other maintenance must be performed by licensed personnel.

NOTE

Pilots operating airplanes of other than U.S. registry should refer to the regulations of the registering authority for information concerning preventative maintenance that may be performed by pilots.

ALTERATIONS OR REPAIRS TO AIRPLANE

The FAA should be contacted prior to any alterations on the airplane to ensure that the airworthiness of the airplane is not violated.

NOTE

Alterations and repairs to the airplane must be made by properly licensed personnel.

GROUND HANDLING

The three-view drawing shows the minimum hangar clearances for a standard airplane. Allowances must be made for any special radio antennas.

CAUTION

To ensure adequate propeller clearance, always observe recommended shock strut servicing procedures and tire inflation pressures.

TOWING

One man can move the airplane on a smooth and level surface using the hand tow bar furnished with the loose equipment. Attach the tow bar to the tow lugs on the nose gear lower torque knee.

Where movement is restricted, two men can pivot the airplane on the main wheels. One man should push on the wing leading edge or hold the wing tip, while the other operates the tow bar.

CAUTION

Do not exert force on the propeller or control surfaces. Do not place weight on the empennage to raise the nose wheel. When towing with a tug, limit turns to prevent damage to the nose gear. Do not attempt to tow airplane backward by the tail tiedown ring. Do not tow when the main gear is obstructed by mud or snow.

Care should be used when removing the tow bar to prevent damage to the lubrication fittings on the landing gear.

PARKING

The parking brake push-pull control is located on the left side of the lower subpanel. To set the parking brakes, pull the control out and depress each toe pedal until firm. Push the control in to release the brakes.

NOTE

The parking brake should be left off and wheel chocks installed if the airplane is to remain unattended. Changes in ambient temperature can cause the brakes to release or to exert excessive pressures.

TIE-DOWN

It is advisable to nose the airplane into the wind. Three tie-down lugs are provided: one on the lower side of each wing and a third at the rear of the fuselage.

1. Install the control column lock pin.
2. Chock the main wheels, fore and aft.
3. Using nylon line or chain of sufficient strength, secure the airplane at the three points provided. **DO NOT OVER TIGHTEN**; if the line at the rear of the fuselage is excessively tight, the nose may rise and produce lift due to the angle of attack of the wings.
4. Release the parking brake.

If high winds are anticipated, a vertical tail post should be installed at the rear tie-down lug, and a tie-down line attached to the nose gear.

MAIN WHEEL JACKING

1. Check the shock strut for proper inflation to prevent damage to the landing gear door by the jack adapter and to facilitate installation of the adapter.

CAUTION

Persons should not be in or on the airplane while it is on a main wheel jack.

2. Insert the main wheel jack adapter into the main wheel axle.
3. A scissors-type jack is recommended for raising and lowering the wheel.
4. When lowering the wheel, exercise care to prevent compression of the shock strut, which would force the landing gear door against the jack adapter.

PROLONGED OUT OF SERVICE CARE

The storage procedures listed are intended to protect the airplane from deterioration while it is not in use. The primary objectives of these measures are to prevent corrosion and damage from exposure to the elements.

Flyable Storage - 7 to 30 days - has been considered here. For more extended storage periods consult the Beech Airplane Maintenance Manual and Continental Service Bulletin M74-9 or later issue.

FLYABLE STORAGE - 7 to 30 DAYS

MOORING

If airplane cannot be placed in a hangar, tie down securely at the three points provided. Do not use hemp or manila rope. It is recommended a tail support be used to compress the nose strut and reduce the angle of attack of the wings. Attach a line to the nose gear.

ENGINE PREPARATION FOR STORAGE

Engines in airplanes that are flown only occasionally tend to exhibit cylinder wall corrosion much more than engines that are flown frequently.

Check for correct oil level and add oil if necessary to bring level to full mark.

Run engine at least five minutes at 1200 to 1500 rpm with oil and cylinder head temperatures in the normal operating range.

FUEL CELLS

Fill to capacity to minimize fuel vapor and protect cell inner liners.

FLIGHT CONTROL SURFACES

Lock with internal and external locks.

GROUNDING

Static ground airplane securely and effectively.

PITOT TUBE

Install cover.

WINDSHIELD AND WINDOWS

Close all windows and window vents. It is recommended that covers be installed over windshield and windows.

DURING FLYABLE STORAGE

Each seven days during flyable storage, the propeller shall be rotated by hand. After rotating the engine six revolutions, stop the propeller 60° to 120° from the position it was in.

WARNING

Before rotation of propeller blades, ascertain magneto/start switch is OFF, throttle in CLOSED position, and mixture control is in the IDLE CUT-OFF position. Always stand in the clear while turning propeller.

If at the end of 30 days the airplane will not be removed from storage, engine shall be started and run. The preferred method is to fly the airplane for 30 minutes.

PREPARATION FOR SERVICE

Remove all covers, clean the airplane and give it a thorough inspection, particularly wheel wells, flaps, and control openings.

Preflight the airplane.

EXTERNAL POWER

When using external power, it is very important that the following precautions be observed:

1. The airplane has a negative ground system. Exercise care to avoid reversed polarity. Be sure to connect the positive lead of the external power unit to the positive terminal of the airplane's external power receptacle and the negative lead to the negative terminal of the external power receptacle. A positive voltage must also be applied to the small guide pin.
2. To prevent arcing, make certain no power is being supplied when the connection is made.
3. Make certain that the battery switch is ON, all avionics and electrical switches OFF, and a battery is in the system before connecting an external power unit. This protects the electronic voltage regulators and associated electrical equipment from voltage transients (power fluctuations).

CHECKING ELECTRICAL EQUIPMENT

Connect an auxiliary power unit as outlined above. Ensure that the current is stabilized prior to making any electrical equipment or avionics check.

CAUTION

If the auxiliary power unit has poor voltage regulation or produces voltage transients the equipment connected to the unit may be damaged.

SERVICING

FUEL SYSTEM

FUEL CELLS

CAUTION

Never leave the fuel cells completely empty for more than a few days, as the cell inner lining may dry out and crack, permitting fuel to diffuse through the walls of the cell after refueling. If the cells are to remain empty for a week or more, a thin coating of light engine oil should be sprayed or flushed onto the inner lining of the cells.

The standard fuel cell installation for serials CE-884 and After, and CJ-156 and After, consists of a 40-gallon capacity (37-gallon usable) fuel cell and filler cap in each wing leading edge. On serials CE-674 thru CE-883 and CJ-129 thru CJ-155, the 25-gallon capacity (22-gallon usable) was the standard installation and the 40-gallon

capacity (37-gallon usable) was the optional installation. The filler neck in this installation contains a visual measuring tab to permit partial filling of the tank. Filling the tank until the fuel touches the bottom of the tab indicates 27 gallons of usable fuel, and filling to the slot on the tab indicates 32 gallons of usable fuel. The airplane must be level for the tabs to indicate accurately.

FUEL DRAINS

Open the three snap-type fuel drains daily during preflight to purge any water from the system. Each fuel cell drain is located on the bottom of the wing just outboard of the fuselage. The system low spot drain is at the bottom of the fuel selector valve. The drain is accessible through a door in the fuselage adjacent to the left wing.

FUEL STRAINERS

At each 50 hour inspection the strainer plug should be removed from the fuel injection control valve, and the fuel injection control valve screen washed in fresh cleaning solvent. After the strainer plug has been reinstalled and safetied the installation should be pressure checked for leakage. The strainer at the bottom of the fuel selector valve should also be removed and cleaned with solvent every 100 hours. To reduce the possibility of contaminated fuel, always cap any disconnected fuel lines or fittings.

Ordinarily the finger strainers in the fuel cell outlets should not require cleaning unless there is a definite indication of solid foreign material in the cells or the airplane has been stored for an extended period.

OIL SYSTEM

CAUTION

Oil consumption tends to be higher during break-in periods on new engines. Prolonged flights should be avoided and oil level brought to full after each flight during this period.

The engine oil filler cap and dipstick is accessible by raising the left cowl door. Sump capacity is 12 quarts.

The oil should be changed and the oil filter should be replaced every 100 hours under normal operating conditions. To assure complete drainage, the engine should be at operating temperature. Change the oil as follows:

1. Remove the access plate from the engine cowl on the lower right side.
2. Locate the oil sump drain plug at the low point of the engine sump.
3. Remove the plug button below the sump drain and insert the oil drain duct.
4. Remove the oil sump drain plug.
5. Remove the oil filter and replace with a new unit. A torque of 18 to 20 ft lbs should be applied to the nut of the oil filter.
6. Replace the oil sump drain plug and fill the engine with oil.

See Consumable Materials and Approved Engine Oils for specified oils.

The engine manufacturer specifies ashless dispersant oils only. However, a straight mineral oil may be used for the first oil change period of 20 to 30 hours, or until oil consumption

has stabilized, in order to promote faster ring seating and oil control. Oils must meet Continental Motors Corporation Specification MHS-24A. Refer to APPROVED ENGINE OILS.

BATTERY

The battery is accessible by opening the right door of the engine cowling. Check the electrolyte level after each 25 hours of operation and add distilled water as necessary. Do not fill past the bottom of the split ring.

CAUTION

Excessive overcharging can cause heating and boiling.

Excessive water consumption may be an indication that the voltage regulator requires resetting. The specific gravity of the electrolyte should be checked periodically (see Shop Manual).

The battery box is vented overboard to dispose of hydrogen gas and electrolyte fumes discharged during the normal charging operation. To ensure disposal of these fumes the vent tube should be checked frequently for obstructions.

TIRES

An inflation pressure of 33 to 40 psi should be maintained on the 7.00 x 6 main wheel tires. The 5.00 x 5 nose wheel tire should be inflated to 40 psi. Maintaining proper tire inflation will minimize tread wear and aid in preventing tire failure caused from running over sharp stones. When inflating tires, visually inspect them for cracks and breaks.

NOTE

Beech Aircraft Corporation cannot recommend the use of recapped tires. Recapped tires have a tendency to swell as a result of the increased temperature generated during takeoff. Increased tire size can jeopardize proper function of the landing gear retract system, with the possibility of damage to the landing gear doors and retract mechanism.

SHOCK STRUTS

The following procedures may be used for servicing both the main and the nose gear shock struts.

TO INFLATE STRUT

1. Check to see that the airplane is empty except for full fuel and oil.
2. While rocking the airplane gently to prevent possible binding of the piston in the barrel, inflate the shock strut until the main gear piston is extended 3 inches (3½ inches on the nose gear).

CAUTION

If a compressed air bottle containing air under extremely high pressure is used, exercise care to avoid over-inflating the shock strut.

WARNING

NEVER FILL SHOCK STRUTS WITH OXYGEN.

3. Remove all foreign material from the exposed piston with a soft cloth moistened with hydraulic fluid.

To Replenish Strut Hydraulic Fluid:

1. Support the airplane on jacks at the wing jack points.
2. Remove the air valve cap, depress the valve core, and allow the strut to fully deflate.
3. Raise and block the strut 1/4 inch from the compressed position.

WARNING

Do not remove the valve body assembly until all air pressure has been released or it may blow off, causing injury to personnel or damage to equipment.

4. Carefully remove the valve body assembly.
5. Fill the strut to the level of the valve body assembly with hydraulic fluid (see Consumable Materials).
6. Slowly extend the strut from the blocked position and replace the valve body assembly.
7. Completely compress the strut to release excess air and oil, then reinstall valve core.
8. Inflate the strut as described in the preceding inflation procedure.

SHIMMY DAMPER

The shimmy damper has a reservoir of fluid carried in the piston rod. Two coil springs installed in the piston rod keep the fluid in the shimmy damper under pressure. As fluid is lost through leakage it is automatically replenished from the reservoir until the reservoir supply is exhausted.

To check the fluid level in the shimmy damper insert a wire approximately 1/32-inch in diameter, through the hole in the disc at the aft end of the piston rod, until it touches the bottom of the hole in the floating piston. Mark the wire, remove it, and measure the depth of the insertion. When the shimmy damper is full, insertion depth is 2 3/16 inches; when empty, 3 1/16 inches.

NOTE

The measuring wire should be inserted in the hole in the floating piston rather than against the piston face to give a more accurate reading. To determine if the wire is inserted in the hole in the floating piston, insert the wire several times, noting insertion depth each time. When the wire is inserted in the hole, the depth will be about 1/4 inch greater than when it rests against the piston face.

When the shimmy damper is found empty or nearly empty, it should be refilled. See Shop Manual.

BRAKES

The brake hydraulic fluid reservoir is located on the firewall in the engine compartment. A dipstick is attached to the reservoir cap. Refer to Consumable Materials for hydraulic

fluid specification.

The brakes require no adjustments since the pistons move to compensate for lining wear.

INDUCTION AIR FILTER

This filter should be inspected for foreign matter at least once during each 50-hour operating period. In adverse climatic conditions, or if the airplane is stored, preflight inspection is recommended.

To Remove Filter:

1. Remove the fuselage nose section grill.
2. Remove the wing nuts securing the filter and remove the filter.

INSTRUMENT PRESSURE SYSTEM

The pressure system incorporates two filters; a pump intake filter and an in-line filter. The pump intake filter is mounted on the rear engine baffle. This filter should be changed every 500 hours. If the airplane is operated in dusty conditions, the filter should be changed more frequently.

The in-line filter is located between the pressure regulator and the instruments. This filter should be changed every 300 hours of operation.

PROPELLER

Propeller operation, servicing, and maintenance instructions are contained in the propeller owner's manual furnished with

the airplane.

WARNING

When servicing a propeller, always make certain the ignition switch is *off* and that the engine has cooled completely. **STAND IN THE CLEAR WHEN MOVING A PROPELLER. THERE IS ALWAYS SOME DANGER OF A CYLINDER FIRING WHEN A PROPELLER IS MOVED.**

PROPELLER BLADE BEARING LUBRICATION

1. Remove the propeller spinner.
2. Remove the safety wire and covers from grease zerks.
3. Remove one zerk from each blade.
4. Lubricate by placing the grease gun fitting on one zerk of each blade and filling until the grease is visible from the zerk opening on the opposite side of the blade.
5. Clean the excess grease from the propeller, reinstall the grease zerks, covers, and safety wire on each blade.
6. Reinstall the spinner.

OXYGEN SYSTEM

To service the oxygen system, use the following procedures:

WARNING

Keep hands, tools, clothing, and oxygen equipment clean and free from grease and oil. **KEEP FIRE AND SPARKS AWAY FROM OXYGEN.** Use only recommended leak testing soaps.

1. Read the pressure gage on the oxygen console panel just forward and to the left of the pilot's seat.
2. The gage will not indicate pressure unless the shutoff valve on the oxygen cylinder is open. The shutoff valve is located under the pilot's seat.

CAUTION

Open the cylinder shutoff valve slowly to prevent damage to the system.

3. Close the cylinder shutoff valve and the console panel shutoff valve.
4. Slide the pilot's or copilot's seat aft until the filler valve is clear, then remove the cap from the filler valve and attach the recharging outlet. Open valve on supply bottle slowly.
5. Open the cylinder shutoff valve and slowly fill the cylinder to 1850 ± 50 psi at a temperature of 70°F. This pressure may be increased an additional 3.5 psi for each degree of increase in temperature. Similarly, for each degree of drop in temperature, reduce the cylinder pressure 3.5 psi.
6. Close the cylinder shutoff valve, close the supply bottle valve, remove the recharging outlet, and replace the filler valve cap.
7. Slowly open the cylinder shutoff valve to prepare the system for use.
8. Reinstall the access panel and slide the pilot's seat forward to its original position.
9. The console panel shutoff valve should remain closed until the system is used.

OXYGEN CYLINDER RETESTING

The oxygen cylinders, (light weight cylinders, stamped "3HT" on the plate on the side) must be hydrostatically tested every three years and the test data stamped on the cylinder.

This cylinder has a service life of 4380 pressurizations or twenty-four years, whichever occurs first, and then must be discarded.

MINOR MAINTENANCE

RUBBER SEALS

To prevent sticking of the rubber seals around the windows, doors, and engine cowling, the seals should be coated with Oakite 6 compound. The compound is noninjurious to paint and can be removed by employing normal cleaning methods.

ALTERNATOR

Since the alternator and electronic voltage regulator are designed for use on a negative ground system only, the following precautionary measures must be observed when working on the charging circuit, or serious damage to the electrical equipment will result:

1. When installing a battery, make certain that the ground polarity of the battery and the ground polarity of the alternator are the same.
2. When connecting a booster battery, be sure to connect the negative battery terminals together and the positive battery terminals together.
3. When using a battery charger, connect the positive lead of the charger to the positive battery terminal and the negative lead of the charger to the negative battery terminal.
4. Do not operate an alternator on open circuit. Be sure all

circuit connections are secure.

5. Do not short across or ground any of the terminals on the alternator or electronic voltage regulator.

6. Do not attempt to polarize an alternator.

MAGNETOS

Ordinarily, the magnetos will require only occasional adjustment, lubrication, and breaker point replacement. This work should be done by a BEECHCRAFT Aero or Aviation Center or International Distributor or Dealer.

WARNING

To be safe, treat the magnetos as hot whenever a switch lead is disconnected at any point; they do not have an internal automatic grounding device. The magnetos can be grounded by replacing the switch lead at the noise filter capacitor with a wire which is grounded to the engine case. Otherwise, all spark plug leads should be disconnected or the cable outlet plate on the rear of the magneto should be removed.

CLEANING

EXTERIOR PAINTED SURFACES

WARNING

Do not expose control surface trim tab hinge lines and their pushrod systems to the direct stream or spray of high-pressure, soap-and-water washing equipment. Fluid dispensed at

high pressure could remove the protective lubricant, allowing moisture from heavy or prolonged rain to collect at hinge lines, and then to freeze at low temperatures. After high-pressure or hand washing, and at each periodic inspection, lubricate trim tab hinge lines and trim tab pushrod end fittings (Brayco 300 per Federal Specification VV-L-800 preferred). See Consumable Materials.

CAUTION

When cleaning landing gear areas with solvent, especially if high-pressure equipment is used, exercise care to avoid washing away grease from landing gear components. After washing the landing gear areas with solvent, lubricate all lubrication points, or premature wear may result.

Do not apply wax, polish, rubbing compound, or abrasive cleaner to any uncured painted surface. Use of such items can permanently damage the surface finish. Also, waxes and polishes seal the paint from the air and prevent curing.

Alkyd enamel (sometimes called "automotive enamel"), acrylic enamel, lacquer, and dope finishes require a curing period of approximately 90 days; Acrylic urethane, polyester urethane, and epoxy finishes undergo a curing process for a period of 30 days after application. Wash uncured painted surfaces with a mild non-detergent soap (MILD detergents can be used on urethane finishes) and cold or lukewarm water only. Use soft cloths, keeping them

free of dirt and grime. Any rubbing of the surface should be done gently and held to a minimum to avoid damaging the paint film. Rinse thoroughly with clear water. Stubborn oil or soot deposits may be removed with automotive tar removers.

Prior to cleaning, cover the wheels, making certain the brake discs are covered. Attach the pitot cover securely, and plug or mask off all other openings. Be particularly careful to mask off all static air buttons before washing or waxing. Use special care to avoid removing lubricant from lubricated areas.

When using high-pressure washing equipment, keep the spray or stream clear of wheel bearings, propeller hub bearings, etc., and openings such as pitot tubes, static air buttons, and battery and avionics equipment cooling ducts, which should be securely covered or masked off. Avoid directing high-pressure sprays toward the fuselage, wings, and empennage from the rear, where moisture and chemicals might more easily enter the structure, causing corrosion damage to structural members and moving parts.

Hand washing may be accomplished by flushing away loose dirt with clean water, then washing with a mild soap and water, using soft cleaning cloths or a chamois. Avoid harsh, abrasive, or alkaline soaps or detergents which could cause corrosion or scratches. Thorough clear-water rinsing prevents buildup of cleaning agent residue, which can dull the paint's appearance. To remove oily residue or exhaust soot, use a cloth dampened with an automotive tar remover. Wax or polish the affected area, if necessary.

There is some variation in the procedures required for proper care of the several types of exterior paint. During the curing period, do not make prolonged flights in heavy rain or

sleet, and avoid all operating conditions which might cause abrasion or premature finish deterioration. Alkyd enamel, lacquer, and dope finishes must be polished and waxed periodically to maintain luster, and to assure protection from the weather. Acrylic enamel should be waxed, and may be polished, if desired. Acrylic urethane may be waxed for protection from the elements, but should not be polished unless polishing or buffing is required to restore a damaged area. Waxing of polyester urethane finishes, although not required, is permitted; however, never use abrasive cleaner type waxes, polishes, or rubbing compounds, as these products cause eventual deterioration of the characteristic urethane gloss. Epoxy finishes should be waxed on a regular basis, and may be polished and buffed to restore appearance should "chalking" occur. For waxing, select a high quality automotive or aircraft waxing product. Do not use a wax containing silicones, as silicone polishes are difficult to remove from surfaces. A buildup of wax on any exterior paint finish will yellow with age; therefore, wax should be removed periodically. Generally, aliphatic naphtha (see Consumable Materials) is adequate and safe for this purpose.

NOTE

Before returning the airplane to service, remove all maskings and coverings, and re-lubricate as necessary.

WINDSHIELD AND WINDOWS

The windshield and plastic windows should be kept clean

and waxed at all times. To prevent scratches, wash the windows carefully with plenty of soap and water, using the palm of the hand to feel and dislodge dirt and mud. A soft cloth, chamois or sponge may be used, but only to carry water to the surface. Rinse thoroughly, then dry with a clean, moist chamois. Rubbing the surface of the plastic with a dry cloth builds up an electrostatic charge which attracts dust particles in the air.

Remove oil and grease with a cloth moistened with isopropyl alcohol. Never use gasoline, benzine, alcohol, acetone, carbon tetrachloride, fire extinguisher fluid, anti-ice fluid, lacquer thinner, or glass cleaner. These materials will soften the plastic and may cause it to craze.

After thoroughly cleaning, the surface should be waxed with a good grade of commercial wax. The wax will fill in minor scratches and help prevent further scratching. Apply a thin, even coat of wax and bring it to a high polish by rubbing lightly with a clean, dry, soft flannel cloth. Do not use a power buffer; the heat generated by the buffing pad may soften the plastic.

ENGINE

Clean the engine with neutral solvent. Spray or brush the fluid over the engine, then wash off with water and allow to dry. Solutions which may attack rubber or plastic should not be used.

INTERIOR

To remove dust and loose dirt from the upholstery, headliner, and carpet, clean the interior regularly with a vacuum cleaner.

Blot up any spilled liquid promptly with cleansing tissue or rags. Do not pat the spot; press the blotting material firmly and hold it for several seconds. Continue blotting until no more liquid is taken up. Scrape off sticky materials with a dull knife, then spot-clean the area.

Oily spots may be cleaned with household spot removers, used sparingly. Before using any solvent, read the instructions on the container and test it on an obscure place on the fabric to be cleaned. Never saturate the fabric with a volatile solvent; it may damage the padding and backing materials.

Soiled upholstery and carpet may be cleaned with foam-type detergent used according to the manufacturer's instructions. To minimize wetting the fabric, keep the foam as dry as possible and remove it with a vacuum cleaner.

The plastic trim, instrument panels, and control knobs need only be wiped with a damp cloth. Oil and grease on these surfaces can be removed with a cloth moistened with isopropyl alcohol. Volatile solvents, such as gasoline, benzine, acetone, carbon tetrachloride, fire extinguisher fluid, anti-ice fluid, lacquer thinner, or glass cleaner should not be used. These materials will soften the plastic and may cause it to craze.

LUBRICATION POINTS

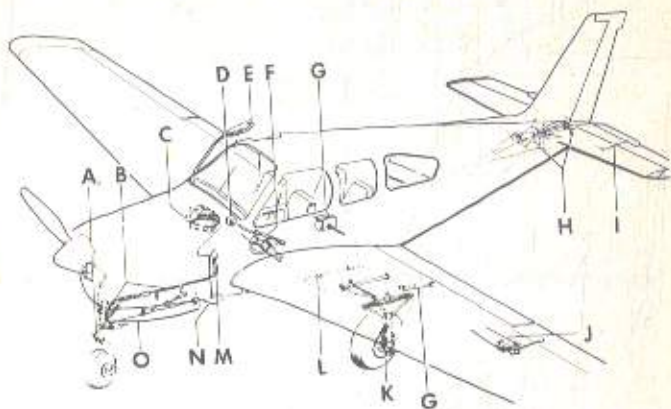

A

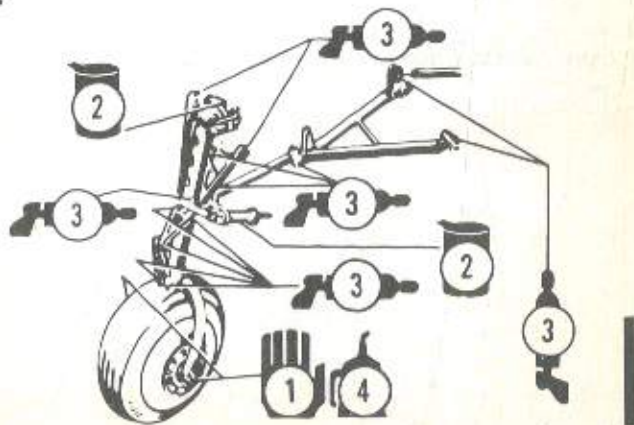

NOSE GEAR RETRACT

B

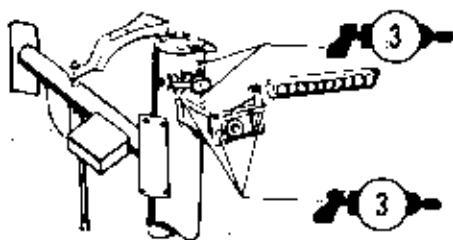

NOSE WHEEL STEERING

C

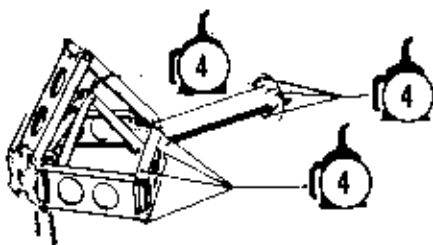

CONTROL COLUMN LINKAGE

D

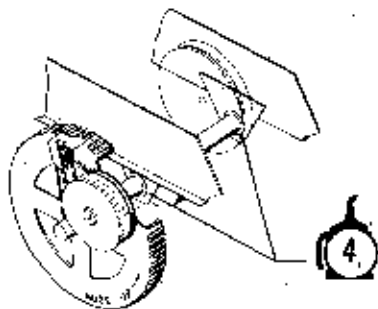

ELEVATOR TRIM CONTROL

E

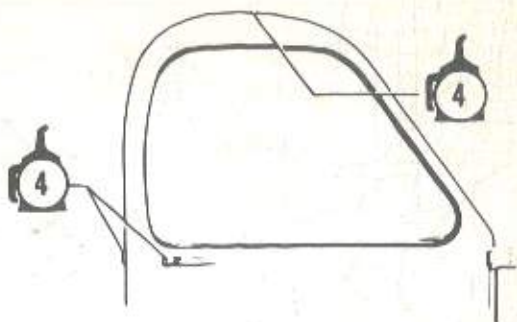

CABIN DOOR

F

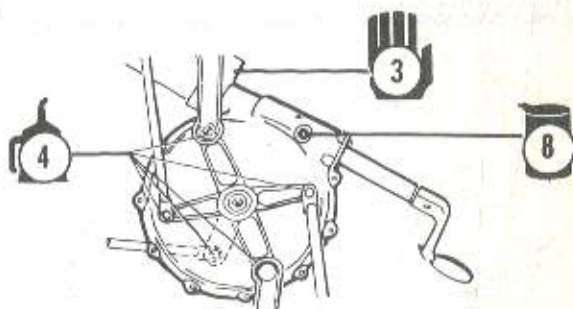

LANDING GEAR ACTUATOR GEAR BOX

G

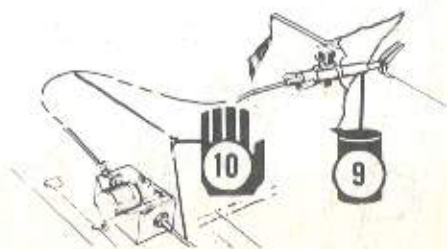

FLAP MOTOR AND ACTUATOR

H

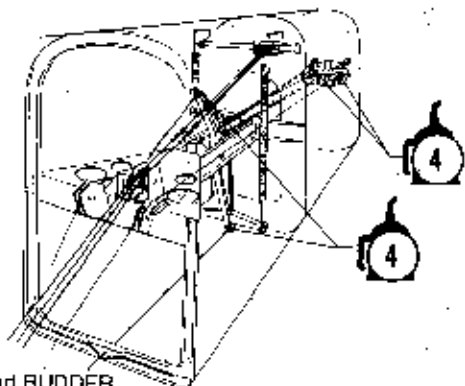

ELEVATOR and RUDDER
CONTROL MECHANISM

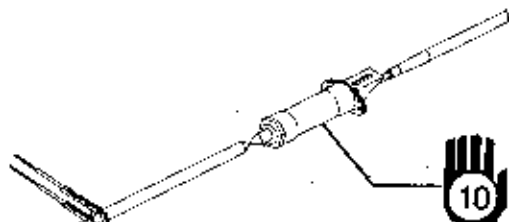

ELEVATOR TAB ACTUATOR

J

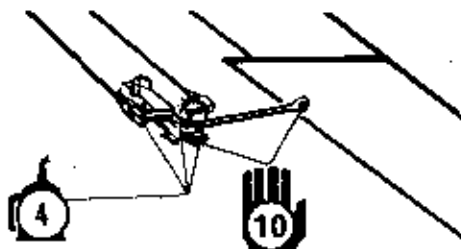

AILERON BELL CRANKS

K

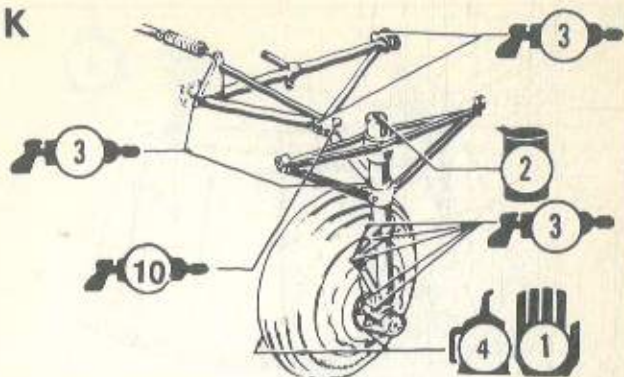

MAIN GEAR RETRACT

L

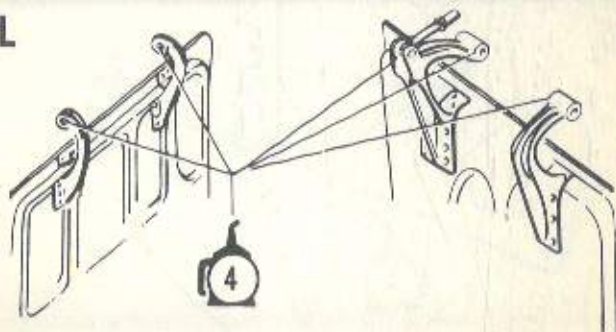

MAIN GEAR DOOR HINGES

M

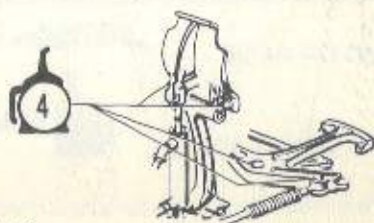

RUDDER PEDALS

N

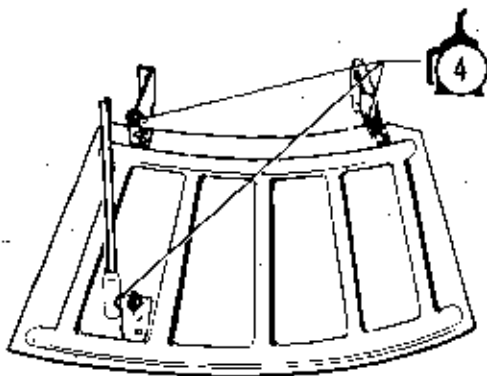

COWL FLAP HINGES

O

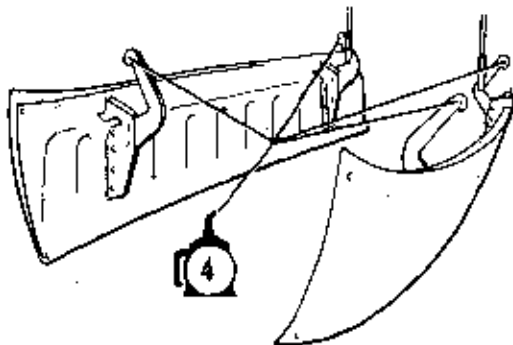

NOSE GEAR DOOR HINGES



HAND OR PACK



ZERK FITTING



FLUID CONTAINER



SQUIRT CAN

NOTE: Letters are keyed to the Service Schedule; Numbers refer to items in the Consumable Materials Chart.

Beech Bonanza F-33

(A)

Bottom Tab = 27 Gallons usable Fuel
Defent on Tab = 32 Gallons usable Fuel

(B)

Drains - Three

(1) one in each fuel sump on under side of each wing

(2) One in fuel selector valve inboard of left wing root [Strainer + Drain]

<u>Weight</u>	
250 - me - Pilot	3400 - Gross
200 - copilot	3140 -
<hr/>	<hr/>
450	260#
444 - Fuel	Person
<hr/>	
894 - Total	
2255 - Empty weight	
<hr/>	
3,149 -	

weight

RECOMMENDED SERVICING SCHEDULE

INTERVAL	ITEM	LOCATION (Letters refer to Lubrication Points Diagram)	(Number refers to item on Consumable Materials)
Pre-flight	Check engine oil level Drain fuel cell drains Drain fuel system low spot drain Service fuel cells	Upper left side of engine Bottom of wing near wing root Bottom of fuselage, left side Top of wings, leading edge	5 — 6
25 Hrs	Check battery electrolyte	Under right cowling door	See Shop Manual
50 Hrs	Clean fuel injection control valve screen Clean induction air filter Drain static air lines	Lower engine compartment Behind nose section grill Behind aft cabin bulkhead and at Emergency Static Source	7 — —

100 Hrs	Check air conditioner evaporator module filter; replace if required Change engine oil Install oil filter Clean fuel selector valve strainer Lub aileron control linkage and control rod ends Lub cabin door mechanism Lub control column linkage Lub cowl flap hinges Lub elevator and rudder control mechanism Lub landing gear door hinges Lub landing gear retract mechanism and uplock rollers Lub nose wheel steering mechanism Lub rudder pedals Lub wheel bearings Lub wheel bearings and felt seals	Forward of left front seat Lower side of engine Upper left side of engine Left side belly Each wing (J) Aft edge of cabin door (E) Forward of instrument panel (C) Bottom of cowl (N) Forward of tail bulkhead (H) Edge of wheel well (L) (O) Wheel wells (A) (K) Nose wheel well (B) Cockpit (M) Nose and main wheels (A) (K) Nose and main wheels (A) (K)	5 7 4 & 10 4 4 4 4 4 4 3, 10 3 4 1 4 & 1
†			
††			

RECOMMENDED SERVICING SCHEDULE (Continued)

INTERVAL	ITEM	LOCATION (Letters refer to Lubrication Points Diagram)	(Number refers to item on Consumable Materials)
300 Hrs	Flap motor (brushes) (Prior to CE-683 and CJ-129) Service landing gear actuator gear box Change pressure system in-line filter	Under floor in cabin (G) Under front seat (F) Forward of instrument panel	8 Airborne Mfg. 1,14-7
500 Hrs	Change pressure pump intake filter	Engine compartment	Airborne Mfg. 1,12-1
600 Hrs	Service landing gear motor reduction gears Flap motor gear box (prior to CE-683 and CJ-129)	Under front seat (F) Under floor in cabin (G)	9 10
900 Hours	Flap Flax drive shafts Flap actuators	Under floor in cabin (G) Inside wing aft of wheel well (G)	10 9

As Req	Lub elevator lab actuators Air conditioner compressor oil level Air conditioner refrigerant	Elevator (I) See shop manual	10 Suniso No. 5 or Texaco Capella E 500 viscosity Refrigerant No. 12
Note 3	Replace emergency locator transmitter battery	Right side of aft fuselage	

NOTES:

1. Anytime the control surfaces are altered, repaired, or repainted, they must be rebalanced per the Shop Manual.
 2. Check the wing bolts for proper torque at the first 100-hour inspection and at the first 100-hour inspection after each reinstallation of the wing attach bolts.
 3. ELT Rechargeable Batteries: Recharge after one cumulative hour of use or after 50% of the useful charge life.
- † ELT Non-rechargeable Batteries: Replace after one cumulative hour or after 50% of the useful life. Lubricate aileron control rod ends in place using SAE 20 or SAE 10W30 oil or remove aileron control rod assembly, clean and lubricate control rod ends using MIL-G-23827 grease. Rotate rod end eyeball to assure adequate lubricant coverage. Check aileron rigging after reinstallation of rod end assembly.
- †† Lightly saturate felt seals with 10W30 oil (remove excess by pressing slightly) also coat the sides and outer diameter with the same type of grease used on the bearings.

CONSUMABLE MATERIALS

Only the basic number of each Military Specification is included in the Consumable Materials Chart. No attempt has been made to update the basic number with the letter suffix that designates the current issues of the various specifications.

Vendors listed as meeting Federal and Military Specifications are provided as reference only and are not specifically recommended by Beech Aircraft Corporation; consequently, any product conforming to the specification listed may be used. The products listed below have been tested and approved for aviation usage by Beech Aircraft Corporation, by the vendor, or by compliance with the applicable specifications. Other products that are locally procurable which conform to the requirements of the applicable Military Specification may be used even though not specifically included herein.

It is the responsibility of the operator/user to determine the current revision of the applicable Military Specification prior to usage of that item. This determination may be made by contacting the vendor of a specific item.

CONSUMABLE MATERIALS

ITEM	MATERIAL	SPECIFICATION
1.	Lubricating Grease Wheel Bearing <i>DO NOT MIX</i>	Aeroshell 5 or MIL-G-81322
2.	Hydraulic Fluid	MIL-H-5606
*3.	Lubricating Grease, General Purpose Wide Temperature	MIL-G-81322
4.	Lubricating Oil	SAE No. 20 or 10W30
**5.	Engine Oil	SAE No. 30 (Below 40°F) SAE No. 50 (Above 40°F) Approved Multiviscosity Oils
***6.	Engine Fuel	100LL (Blue)
7.	Solvent	Federal Specification, PD680
8.	Lubricant	Mobil Compound GG or Mobil 636
9.	Lubricating Oil, Gear	MIL-L-10324 or MIL- L-2105C, Grade 75W
10.	Grease, Aircraft and Instruments, Gear and Actuator Screw	MIL-G-23827
†11.	Lubricant, Rubber Seal	Oakite 6 Compound

Section VIII
Handling, Serv & Maint

BEECHCRAFT Bonanza F33A
CE-674 and after

ITEM	MATERIAL	SPECIFICATION
12.	Naphtha, Aliphatic	Federal Specification TT-N-95
††13.	Tape, Anti-Seize, Tetrafluorethylene	MIL-T-27730
14.	Leak Test Compound, Oxygen Systems	MIL-L-25567
15.	Oxygen, Aviators Breathing	MIL-O-27210
16.	Lubricating Oil, General Purpose, Preservative (Water- Displacing, Low Temperature)	●Brayco 300 per Federal Specifi- cation VV-L-800 (Preferred)

Alternates for Brayco 300:

Lubricant	●●CRC 3-36
	●●●LPS No. 1
	●●●●WD-40

- * In extremely cold climates use MIL-G-23827 grease in place of MIL-G-81322. (These greases harmful to paint.)
- ** Ashless dispersant oil (latest revision of Teledyne Continental Motors Corp. Spec. MHS-24) recommended; straight mineral oils recommended during break-in period. See servicing data.
- ***100LL (Blue) preferred, or 100 (Green).
- † Product of Oakite Products, Inc., 50 Valley Road, Berkley Heights, N.J. 07922.
- †† For sealing tapered threads on high pressure oxygen lines.
 - Product of Bray Oil Co.,
1925 North Marianna
Los Angeles, Calif. 90032
 - Product of CRC Chemicals, Inc.,
Warminster, Pa. 18974
 - Product of LPS Research Laboratories, Inc.,
2050 Cotner Ave,
W. Los Angeles, Calif. 90025
 - Product of WD-40 Company,
1061 Cudahy Place,
San Diego, Calif. 92110

APPROVED ENGINE OILS

<i>COMPANY</i>	<i>BRAND NAME</i>
BP Oil Corporation	BP Aero Oil D65/80
Castrol Limited (Australia)	Grade 40, Castrolaero AD, Type III Grade 50, Castrolaero AD, Type II
Continental Oil Co.	Conoco Aero S(SAE 10W30)
Delta Petroleum Co.	Delta Avoil - Grades 30, 40 & 50
Gulf Oil Corporation	Gulfpride Aviation AD
Humble Oil & Refining Co.	Esso Aviation Oil Enco Aviation Oil
Pennzoil Company	Pennzoil Aircraft Engine Oil Heavy Duty Dispersant Grades 30, 40, & 50
Phillips Petroleum Co.	Phillips 66 Aviation Oil Type A
Quaker State Oil & Ref. Corp.	Quaker State AD Aviation Engine Oil Grades 20W/30, 40 & 50
Sinclair Refining Co.	Sinclair Avoil 20W40
Shell Oil Co.	Aeroshell Oil W (in 4 grades) Grade 120 (Nominal SAE 60) Military Grade 1120 Grade 100 (Nominal SAE 50) Military Grade 1100 Grade 80 (Nominal SAE 40) Military Grade 1080

COMPANY

BRAND NAME

Grade 65 (Nominal SAE 20 or 30)
Military Grade 1065

Socony - Mobil

Mobil Aero Oil 65
Mobil Aero Oil 80
Mobil Aero Oil 100
Mobil Aero Oil 120

Texaco, Inc.

Texaco Aircraft Engine Oil
Premium AD, Grades 65, 80, 100

Union Oil Co. of
California

Union Engine Oil H D Grades
80 & 100

This chart lists all oils which were certified as meeting the requirements of Teledyne Continental Motors Corporation Specification MHS-24B at the time this handbook was published. Any other oil which conforms to this specification may be used.

BULB REPLACEMENT CHART

LOCATION	14-VOLT	NUMBER	28-VOLT
Compass light	330		327
Dome light, cabin	89		1864
Elevator tab position indicator light	53R		1819
Fuel selector placard light	53		327
Instrument flood light, overhead	1813(GE)		313
Instrument light, post	330		327
Instrument wedge light	58-380022-9	58-380022-11	
Landing gear position light	330		327
Landing light, nose section	4313		4596
Taxi light, nose shock strut	4313		4596
Navigational light, tail cone	1073	A-2064-1683	
Combination strobe navigational light	633		NONE
Navigational light, wing	1512		A-7512-24
Overvoltage warning light	330		327
Rotating beacon (Grimes)	A-7079B-12		A-7079B-24
Rotating beacon (Whelen)	Not applicable		WRM-1939
Strobe lights (Grimes)			
Wing			
Tail/navigation			
		See Shop Manual	
		See Shop Manual	

OVERHAUL OR REPLACEMENT SCHEDULE

The first overhaul or replacement should be performed not later than the required period. The condition of the item at the end of the first period can be used as a criterion for determining subsequent periods applicable to the individual airplane or fleet operation, providing the operator has an approved monitoring system.

The time periods for inspection noted in this handbook are based on an average usage and average environmental conditions.

SPECIAL CONDITIONS CAUTIONARY NOTICE

Airplanes operated for Air Taxi or other than normal operation and airplanes operated in humid tropics or cold and damp climates, etc., may need more frequent inspections for wear, corrosion and/or lack of lubrication. In these areas periodic inspections should be performed until the operator can set his own inspection periods based on experience.

NOTE

The required periods do not constitute a guarantee that the item will reach the period without malfunction, as the aforementioned factors cannot be controlled by the manufacturer.

<i>COMPONENT</i>	<i>OVERHAUL OR REPLACE</i>
Starter	Inspect at engine overhaul; overhaul or replace on condition
Alternator	On condition
Oil cooler	On condition (replace when contaminated)
Propeller	At engine overhaul or at unscheduled engine change but not to exceed 1500 hours or 3 years
Propeller controls	On condition
Propeller governor	At engine overhaul but not to exceed 1500 hours or 3 years
Fuel pressure pump	Every 1500 hours
Cabin heat muff	Inspect every 100 hours

FUEL SYSTEM

Fuel cells	On condition
Wing fuel quantity transmitters	On condition
Fuel cell drain valve	On condition
Fuel system check valves	On condition
Fuel selector valve	Inspect every 600 hours; overhaul every 1200 hours (See Maintenance Manual)
Auxiliary fuel boost pump	Every 1200 hours
Hose carrying flammable liquid	At engine overhaul or every 5 years
All hose not carrying flammable liquid	On condition

COMPONENT OVERHAUL OR REPLACE

INSTRUMENTS

Turn coordinator	On condition
Altimeter	Inspect and calibrate every 24 months per FAA directive
Directional gyro	On condition
Gyro horizon	On condition
Gyro pressure	On condition
Engine indicator units	On condition
Airspeed indicator	On condition
Rate-of-climb	On condition
Fuel quantity indicator	On condition
Manifold pressure/fuel flow indicator	On condition
Tachometer	On condition
Flap Position Indicator	On condition
Free air temperature indicator	On condition
All hose	On condition
Pressure system filter	Every 300 hours
Air pressure regulator valve	On condition

ELECTRICAL SYSTEM

Battery master relay	On condition
All other relays	On condition
Voltage regulator	On condition
Starter relay	On condition
Standby generator	Inspect every 100 hours: Overhaul or replace every 1500 hours,

COMPONENT OVERHAUL OR REPLACE

FLAPS AND FLIGHT CONTROLS

Flight controls	On condition
Elevator tab actuator	On condition
Flap motor and drives (Prior to CE-683 and CJ-129)	Every 2000 hours or on condition
Flap motor brushes (Prior to CE-683 and CJ-129)	On condition
Flap Motor (CE-683 and after, CJ-129 and after)	Every 5000 hours or 10,000 cycles
Flap actuators	Every 2000 hours
Flap flexible shaft	Every 2000 hours

MISCELLANEOUS

Seat belts and shoulder harnesses	Inspect every 12 months or on condition
Hand fire extinguisher	Inspect every 12 months, recharge as necessary
Cabin heating and venti- lating ducts	On condition, inspect every 12 months
Oxygen regulator	Every 48 months or 2000 hours
Oxygen cylinder	3HT cylinders: Hydrostatic test every three years, replace after 4,380 pressurizations or 24 years.

* The recommended engine overhaul period applies only to engines with nickel-coated exhaust valves or nimonic exhaust valves, provided that normal periodic inspections are properly carried out. Engines that should conform to a shorter TBO period are listed in Teledyne Continental Motors Corporation Service Bulletin M74-20, Rev. 1, dated November 7, 1974, or later issue. Continental recommends a maximum of 1200 hours TBO on engines employed in aerial top dressing, dusting, or spraying.

With particular attention to throttle response, smooth power and oil consumption, a qualified certificated mechanic must determine that the engine is operating normally at the time of each periodic inspection.

SECTION IX SUPPLEMENTS

NOTE

The supplemental data contained in this section is for equipment that was delivered on the airplane, and for standard optional equipment that was available whether or not it was installed. Supplements for equipment for which the vendor obtained a Supplemental Type Certificate were included as loose equipment with the airplane at the time of delivery. These and other Supplements for other equipment that was installed after the airplane was delivered new from the factory should be placed in this SUPPLEMENTS Section of this Pilot's Operating Handbook and FAA Approved Airplane Flight Manual.

*ADDITIONAL SUPPLEMENTS
ARE IN A SEPARATE BOOK.
Y30W*

**PILOT'S OPERATING HANDBOOK
AND
FAA APPROVED AIRPLANE FLIGHT MANUAL
P/N 33-590009-13
(CE-674 AND AFTER)
LOG OF SUPPLEMENTS**

<i>FAA Supplements must be in the airplane for flight operation when subject equipment is installed.</i>			
Part Number	Subject	Rev No.	Date
SA785CE	Hartzell Propellers	2	02/80
*33-590006-13	Acrobatic Supplement for the F33C	4	05/86
33-590009-19	Collins ANS-351 Area Navigation System	1	12/78
33-590009-25	Standby Generator Power System (28-Volt)		10/78
*33-590009-29	Operation of United Kingdom Registered Aircraft		04/89
35-590110-13	Landing Gear Safety System	4	12/78
35-590118-13	King KN-74 Area Navigation System	3	12/78
35-590118-19	Standby Generator Power System (14-Volt)	5	09/78
35-590118-25	Electrothermal Propeller Deice (2 and 3-Blade)	2	11/77
35-590118-35	Air Conditioning System	1	11/77
35-590118-43	King KNS-80 Integrated Navigation System	1	12/78
36-590002-29	28-Volt Propeller Deice	1	12/78
36-590002-31	Bendix NP-2041A Nav Computer Programmer	1	01/80
36-590002-33	AirData AD-511/AD-511G Area Navigation System		03/80

FAA Supplements must be in the airplane for flight operation when subject equipment is installed.

Part Number	Subject	Rev No.	Date
36-590002-35	Hartzell Constant-Speed Three-Bladed Propeller		04/80
36-590002-39	Fuel Selector Valve Stop Installation		03/83
36-590002-47	Full Flap Warning Horn System		12/90
36-590002-49	Landing Gear Warning Light System		12/90
36-590002-51	Low Throttle Landing Gear Retract Prevention, Gear Warning System		12/90
36-590002-53	Bendix/King KLN-88 Multi-Chain Lorah Navigation System		10/90
36-590003-11	King KNS-81 Integrated Navigation System	2	10/83
36-590006-23	Standby Instrument Air Pressure System	2	02/86
58-590000-49	Inside Cabin Door Handle With Open/Closed Placard		12/90

NOTE: Supplements applicable to equipment other than installed may be removed from the manual at the discretion of the owner/operator.

** Supplements marked with an asterisk will not be supplied with handbooks sold through Authorized Beech Outlets due to their limited applicability. If a document is required for your airplane, please order the document through normal channels.*

**BEECHCRAFT BONANZA
F33A, F33C, A36, AND B36TC
LANDPLANES**

**PILOT'S OPERATING HANDBOOK
AND FAA APPROVED
AIRPLANE FLIGHT MANUAL SUPPLEMENT**

FOR THE

**BENDIX/KING KLN88
MULTI-CHAIN
LORAN NAVIGATION SYSTEM**

**THIS SUPPLEMENT IS APPLICABLE TO
PILOT'S OPERATING HANDBOOK AND
FAA APPROVED AIRPLANE FLIGHT MANUALS:**

P/N 33-590009-13

P/N 36-590002-37

P/N 36-590006-19

Airplane Serial Number: _____

Airplane Registration Number: _____

FAA Approved:

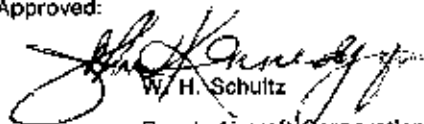

W. H. Schultz

Beech Aircraft Corporation

DOA CE-2

COPYRIGHT © BEECH 1990

FAA Approved

P/N 36-590002-53

Issued: October, 1990

1 of 7

CONTENTS

GENERAL	Page 2
LIMITATIONS	Page 3
EMERGENCY PROCEDURES	Page 4
NORMAL PROCEDURES	Page 4
PERFORMANCE	Page 4
WEIGHT & BALANCE	Page 4
SYSTEMS DESCRIPTION	Page 4
HANDLING, SERVICING, AND MAINTENANCE	Page 7

GENERAL

The information in this supplement is FAA-approved material and must be attached to the Pilot's Operating Handbook and FAA Approved Airplane Flight Manual when the airplane has been modified by installation of the Bendix/King KLN88 LORAN Navigation System, in accordance with Beech-approved data.

The information in this supplement supersedes or adds to the basic Pilot's Operating Handbook and FAA Approved Airplane Flight Manual only as set forth within this document. Users of the handbook are advised always to refer to the supplement for possibly superseding information and placarding applicable to operation of the airplane.

The KLN88 LORAN Pilot's Guide, Bendix/King P/N 006-08458-0000, dated 8/89 or later issue, is available from General Aviation Avionics Division, Bendix/King, Olathe, Kansas 66062-1212. It is the responsibility of the owner/operator to maintain the above Pilot's Guide in current status.

LIMITATIONS

1. The KLN88 LORAN Navigation System is approved as a two-dimensional LORAN-C navigation system

FAA Approved
P/N 36-590002-53
Issued: October, 1990

in accordance with Advisory Circular 20-121A for enroute VFR/IFR operations within the conterminous United States and Alaska.

2. The use of the KLN88 system for approaches is prohibited.
3. The KLN88 Pilot's Guide, P/N 006-08458-0000, 8/89 or later issue, must be immediately available to the pilot whenever navigation is predicated on the use of the LORAN-C system.
4. During KLN88 operation, other navigation equipment required for the specific type of operation must be installed and operable.
5. The KLN88 position information must be checked for accuracy (reasonableness) against a visual ground fix or other approved navigation equipment under the following conditions:
 - a. Prior to compulsory reporting points during IFR operations when not under radar surveillance or control.
 - b. At or prior to arrival at each enroute waypoint during operation on an approved RNAV route.
 - c. Prior to and at hourly intervals during operation off of approved RNAV routes.
6. If the data base has expired, use of the KLN88 system for IFR operation is prohibited, unless the information used for navigation is verified for accuracy against current approved data.

EMERGENCY PROCEDURES

No change.

FAA Approved
P/N 36-590002-53
Issued: October, 1990

3 of 7

NORMAL PROCEDURES

Normal operating procedures for the KLN88 LORAN Navigation System are outlined in the KLN88 Pilot's Guide, P/N 006-08458-0000, 8/89 or later issue.

PERFORMANCE

No change.

WEIGHT & BALANCE

No change.

SYSTEMS DESCRIPTION

GENERAL

The KLN88 is a long-range, LORAN-C based navigation system which provides the pilot with present position information and display guidance information based upon a pilot-programmed flight plan. The basic system consists of a panel-mounted unit which contains the LORAN-C sensor, the navigation computer, a CRT display, and all the controls required to operate the unit. It also houses the data base cartridge which plugs directly into the back of the unit.

The KLN88 system has analog outputs which are capable of driving the left/right deviation bar of the pilot's HSI. In addition, the system is capable of being coupled to an AutoPilot and Flight Director. Outputs to remote annunciators to indicate the status of certain KLN88 functions are also provided. The system uses its present position information to determine crosstrack error, distance-to-waypoint, ground speed, track angle, time-to-waypoint, bearing-to-waypoint, and advisory VNAV guidance.

FAA Approved

P/N 36-590002-53

Issued: October, 1990

The internal data base of the KLN88 contains a vast amount of information on airports, navaids, intersections, special use airspace, and other aeronautical information pertinent to navigation. A periodic update of the data base is made by replacing the obsolete cartridge with a current one. In addition to the published data base, up to 250 user-defined waypoints and up to 9 flight plans may be created and stored. The KLN88 contains an internal lithium battery to retain the stored information.

SYSTEM ANNUNCIATORS

The following remote annunciators are provided and are located on the pilot's instrument panel:

MSG: Illuminates whenever the system senses a condition requiring pilot attention.

WPT: Illuminates approximately 20 seconds prior to the beginning of turn anticipation or approximately 36 seconds prior to reaching a Direct To waypoint.

WRN: Illuminates whenever the system determines that its estimated position error is greater than 1.7 NM.

SYSTEM SWITCHES

A two-position selector switch, labeled FD/HSI, is located on the pilot's instrument panel. When the NAV portion of this switch is illuminated, the NAV1 Frequency Control Head provides basic VOR/LOC/GS navigation data to the pilot's HSI and Flight Director. When the LORAN portion is illuminated, control is transferred to the KLN88 which drives the pilot's HSI and the Flight Director command bars. Anytime an ILS/LOC frequency is selected on the NAV1 Frequency Control Head while operating with the LORAN mode selected, the system will automatically switch to NAV mode.

FAA Approved
P/N 36-590002-53
Issued: October, 1990

PILOT'S HSI

1. NAV SELECTED

- a. The course must be manually selected using the Course Knob.
- b. VOR and LOC tuning is controlled by the NAV1 Frequency Control Head.
- c. VOR and LOC signals provide left/right steering information to the Course Deviation Indicator.
- d. Course deviation is angular. Full scale left or right deviation is 10° in VOR mode and 2.5° in LOC mode.

2. LORAN SELECTED

- a. The course must be manually selected using the Course Knob.
- b. The KLN88 provides left/right steering information to the Course Deviation Indicator.

1) Enroute-Leg Mode:

The CDI displays left/right deviation from the Desired Track (the great circle distance between two waypoints).

2) Enroute-OBS Mode:

The CDI displays left/right deviation from the selected course.

- c. Course deviation is linear. Full scale left or right deviation is 5 NM.

HANDLING, SERVICING, AND MAINTENANCE

To replace the KLN88 LORAN data base, refer to the Pilot's Guide, P/N 006-08458-0000, dated 8/89, or later issue.

**BEECHCRAFT BONANZA F33A (CE-748, CE-772
and after), F33C (CJ-149 and after), V35B (D-10097,
D-10120 and after), A36 (E-1111, E-1241 and after),
A36TC (EA-1 thru EA-272 except EA-242), and B36TC
(EA-242, EA-273 and after)
LANDPLANES**

**PILOT'S OPERATING HANDBOOK AND
FAA APPROVED AIRPLANE
FLIGHT MANUAL SUPPLEMENT**

for the

**STANDBY INSTRUMENT AIR
PRESSURE SYSTEM**

GENERAL

The information in this supplement is FAA-approved material and must be attached to the Pilot's Operating Handbook and FAA Approved Airplane Flight Manual when the airplane has been modified by installation of the Standby Instrument Air Pressure System during manufacture or by subsequent incorporation of Beech Kit P/N 36-5009, P/N 36-5011, P/N 36-5014, or P/N 36-5015 in accordance with Beech-approved data.

The information in this supplement supersedes or adds to the basic Pilot's Operating Handbook and FAA Approved Airplane Flight Manual only as set forth below. Users of the manual are advised always to refer to the supplement for possibly superseding information and placarding applicable to operation of the airplane.

LIMITATIONS

1. The system is to be used only in the event of an instrument air pressure system failure.

FAA Approved
Revised: February, 1986
P/N 36-590006-23

1 of 5

2. Do not operate the system unless the engine is running (except in BEFORE STARTING procedures).

EMERGENCY PROCEDURES

SYSTEMS EMERGENCIES

INSTRUMENT AIR PRESSURE SYSTEM FAILURE

If failure of the instrument air pressure system occurs, indication of the failure will be noted by: illumination of either a red GYRO WARN annunciator mounted in the glare shield or a red GYRO WARN light installed in the instrument panel; loss of proper indication on the instrument air pressure gage; and loss of all air-driven gyro instruments. If a failure of the instrument air pressure system occurs:

1. STBY GYRO P Switch (located on pilot's subpanel) - ON. The following will result:
 - a. The amber STBY GYRO P annunciator (or STBY GYRO PRESSURE light) will illuminate.
 - b. The red GYRO WARN annunciator (or red GYRO WARN light) will extinguish.
 - c. The instrument air pressure gage will indicate in the green arc.
 - d. The two primary air-driven gyro instruments will resume normal operation.

CAUTION

If instrument air pressure system failure occurs during IFR conditions, land as soon as practical. The flight may be continued to the destination if it can be conducted in VFR conditions. Prior to the next flight, cause of the malfunction should be determined and corrected.

FAA Approved

Revised: February, 1986

P/N 36-590806-23

NOTE

When more than two air-driven gyro instruments, radar, or air-driven autopilot gyros are installed, the standby instrument air pressure system isolates additional instruments and radar, thus supplying air flow only to the two primary air-driven instruments.

NORMAL PROCEDURES

BEFORE STARTING

1. STBY GYRO P - CHECK
 - a. Battery Switch - ON
 - b. GYRO WARN Annunciator (or GYRO WARN light) - CHECK (should be illuminated)
 - c. STBY GYRO P Switch - ON
 - d. STBY GYRO P Annunciator (or STBY GYRO PRESSURE Light) - CHECK (should be illuminated). GYRO WARN annunciator (or GYRO WARN light) will extinguish.
 - e. Instrument Air Pressure Gage - CHECK (should indicate within green arc)
 - f. STBY GYRO P Switch - OFF
 - g. Battery Switch - OFF

CAUTION

To conserve battery power, do not continue this procedure for more than 10-15 seconds.

PERFORMANCE

No change

FAA Approved
Revised: February, 1986
P/N 36-590008-23

WEIGHT AND BALANCE

No change

SYSTEMS DESCRIPTION

STANDBY INSTRUMENT AIR PRESSURE SYSTEM

The standby instrument air pressure system provides sufficient instrument air flow to power two air-driven gyro instruments in the event of an instrument air pressure system failure.

NOTE

When more than two air-driven gyro instruments, radar, or air-driven autopilot gyros are installed, the standby instrument air pressure system isolates additional instruments and radar, thus supplying air flow only to the two primary air-driven instruments.

The standby instrument air pressure system has a pressure pump driven by an electric motor and incorporates two filters: a pump intake filter and an inline filter. The system is located in the engine compartment.

The standby instrument air pressure system is controlled by an on/off switch, placarded STBY GYRO P, located on the pilot's subpanel. A red GYRO WARN annunciator mounted in the glare shield or a red GYRO WARN light installed in the instrument panel will illuminate if failure of the instrument air pressure system occurs. During system operation, an amber STBY GYRO P annunciator mounted in the

FAA Approved

Revised: February, 1986

P/N 36-59006-23

glare shield or an amber STBY GYRO P light installed in the instrument panel will be illuminated. Proper operation of the standby instrument air pressure system is monitored on the instrument air pressure gage. Pressure should be maintained within the green arc.

NOTE

The standby instrument air pressure system is a backup system only and should not be used as a primary source of instrument air pressure.

HANDLING, SERVICING AND MAINTENANCE

STANDBY INSTRUMENT AIR PRESSURE SYSTEM

The standby instrument air pressure system incorporates two filters, a pump intake filter and an inline filter. The pump intake filter is attached to the keel structure on the underside of the engine and the inline filter is located between the pressure regulator and the instruments. The intake filter and the inline filter should be replaced on condition or every 300 hours. Replace both filters when a new pump is installed. The pressure pump should be replaced every 600 hours of system operation.

Approved:



Fav

W. H. Schultz
Beech Aircraft Corporation
DOA CE-2

FAA Approved
Revised: February, 1986
P/N 36-590006-23

5 of 5

**PILOT'S OPERATING HANDBOOK AND
FAA APPROVED AIRPLANE FLIGHT MANUAL
SUPPLEMENT TO THE F33A
for the
ACROBATIC BONANZA F33C (CJ-129 and after)**

GENERAL

The information in this supplement is FAA approved material and must be attached to the Pilot's Operating Handbook and FAA Approved Airplane Flight Manual when the Bonanza F33A has been modified to become the Acrobatic Bonanza F33C.

Refer to the F33A Pilot's Operating Handbook for Description and Servicing of the 28-volt electrical system on airplanes CJ-149 and after.

This supplement supersedes or adds information to the basic Pilot's Operating Handbook and FAA Approved Airplane Flight Manual only as set forth below.

LIMITATIONS

AIRSPEED LIMITATIONS

SPEED	KCAS	KIAS	REMARKS
Maneuvering V_a	143	145	Do Not Make Full or Abrupt Control Movements Above This Speed.
Chandelles, Lazy Eights, Steep Turns	143	145	Maximum Entry Speed
Stalls and Spins	Slow Deceleration		

FAA Approved
Revised: September, 1978
P/N 33-590006-13

WEIGHT LIMITS

Maximum Take-off	2800 lbs
Maximum Landing	2800 lbs
Maximum Ramp	2812 lbs

CENTER OF GRAVITY LIMITS (Landing Gear Extended)

Forward: 78.5 inches aft of datum to 2800 lbs

Aft: 81.0 inches aft of datum to 2800 lbs

MANEUVER LIMITS

MANEUVER RECOMMENDED ENTRY SPEED (IAS)

Chandelle.....	145 KTS
Lazy Eight.....	145 KTS
Steep Turn.....	145 KTS
Loop.....	167 KTS
Cuban 8.....	167 KTS
Immelmann.....	176 KTS
Slow Roll.....	141 KTS
Barrel Roll.....	132 KTS
Single Snap Roll.....	96 KTS
Vertical Reversment.....	96 KTS
Split S.....	79 KTS

WARNING

Do not use abrupt or full control travel at speeds greater than the maximum design maneuvering speed.

Spins are approved. Spins have not been demonstrated in excess of 6 turns.

Inverted flight is limited to 5 seconds.

Acrobatic maneuvers are prohibited with door hold-open installed.

Hesitation rolls are prohibited.

FLIGHT LOAD FACTOR LIMITS

Positive "G" forces should be maintained throughout all approved maneuvers except slow rolls. During slow rolls, negative "G" force is limited to 5 seconds or less duration.

6.0 G positive maneuvering load factor with flaps up.

3.0 G negative maneuvering load factor with flaps up.

3.0 G positive maneuvering load factor with flaps down.

FLIGHT CREW LIMITS

Maximum Occupancy.....Two persons

NOTE

Only the pilot and copilot seats may be occupied. If only one occupant, occupancy is limited to the pilot's seat.

FUEL LIMITATIONS

Do not attempt acrobatic maneuvers with less than 10 gallons usable fuel in the tank being used for acrobatic maneuvers.

Do not attempt acrobatic maneuvers with an asymmetrical fuel loading in excess of 8 gallons.

The Auxiliary Fuel Pump Switch must be in the ACROBATIC BOOST position during acrobatic maneuvers. Select the HIGH BOOST position in the event of a decrease in fuel pressure.

FAA Approved

Revised: September, 1978

P/N 33-590006-13

3 of 28

PLACARDS

On Control Console:

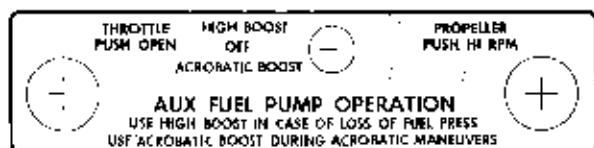

In Full View of Pilot:

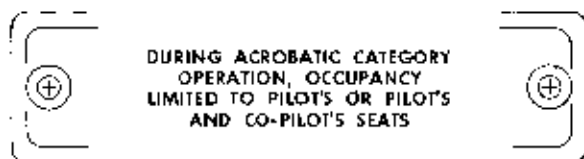

In Full View Of Pilot (If required to meet acrobatic C.G. requirements due to optional equipment configuration):

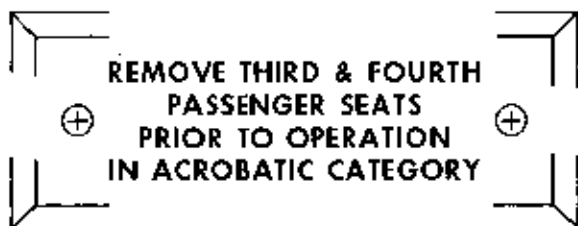

FAA Approved
Revised: September, 1978
P/N 33-500006-13

CJ-149 and After, and airplanes incorporating Kit No. 33-5004-1 (Shoulder Harness and Seat Back Placards)

Center of Instrument Panel:

**SHOULDER HARNESS REEL
OPERATION**

HANDLE FWD - MANUAL LOCK
HANDLE AFT - AUTOMATIC

IF REEL LOCKS, PUSH HANDLE
FORWARD THEN AFT TO
RELEASE

On Windows Adjacent to Passenger Seats:

**SHOULDER HARNESS
MUST BE WORN DURING
TAKE-OFF AND LANDING
WITH SEAT BACK UPRIGHT**

On Windows Adjacent to Pilot's and Copilot's Seats:

SHOULDER HARNESS MUST BE WORN AT
ALL TIMES WHILE AT PILOT POSITIONS.
SNUG LAP BELT WITH BUCKLE CENTERED
IN FRONT OF OCCUPANT.
SEAT BACK MUST BE UPRIGHT FOR TAKEOFF
AND LANDING.

Aft Upper Corner of Copilot's Seat:



FAA Approved
Revised: September, 1978
P/N 33-590006-13

5 of 28

**On Left Side Panel (Airspeed values are IAS):
(CJ-129 thru CJ-149)**

**THIS AIRPLANE MUST BE OPERATED IN COMPLIANCE WITH THE
OPERATING LIMITATIONS STATED IN THE FORM OF PLACARDS,
MARKINGS AND MANUALS.**

REFER TO WEIGHT AND BALANCE DATA FOR LOADING INSTRUCTIONS. OCCUPIED SEATS MUST BE
IN UPRIGHT POSITION DURING TAKE OFF AND LANDING. ALTITUDE LOST DURING STALL
RECOVERY: 300 FT. NO ACROBATIC MANEUVERS APPROVED EXCEPT THOSE LISTED BELOW.

UTILITY CATEGORY AIRPLANE

MAXIMUM WEIGHT 3400 LBS. FLIGHT MANEUVER LOAD FACTOR: FLAPS UP 4.4 G.
FLAPS DOWN 2.0 G.

MANEUVER	MAXIMUM ENTRY SPEED
CHANDLLES, LAZY EIGHT, STEEP TURNS.....	134 KNOTS
STALLS (EXCEPT WHIP STALLS).....	SLOW DECELERATION

NOTE: INTENTIONAL SPINS PROHIBITED

AIRPEED LIMITATIONS

MAXIMUM LANDING GEAR EXTENDED SPEED	154 KNOTS
MAXIMUM DESIGN MANEUVER SPEED	134 KNOTS

ACROBATIC CATEGORY AIRPLANE

MAXIMUM WEIGHT 2800 LBS. FLIGHT MANEUVER LOAD FACTOR: FLAPS UP +6.0 G. -1.0G.
FLAPS DOWN 3.0 G. CENTER OF GRAVITY BETWEEN STA. 78.5 AND STA. 81.0.

CAUTION **INVERTED FLIGHT PROHIBITED.** NEGATIVE G FLIGHT LIMITED TO 5
SECONDS OR LESS AS REQUIRED TO PERFORM APPROVED MANEUVERS.
SEE ACROBATIC SUPPLEMENT TO PILOT'S OPERATING HANDBOOK.

ACROBATIC BOOST PUMP MUST BE ON TO PERFORM THE FOLLOWING

MANEUVER	MAXIMUM ENTRY SPEED
CHANDLLES, LAZY EIGHT, STEEP TURNS.....	145 KNOTS
STALLS AND SPINS.....	SLOW DECELERATION
MANEUVER RECOMMENDED ENTRY SPEED	MANEUVER RECOMMENDED ENTRY SPEED
LOOP.....167 KNOTS	BARREL ROLL.....132 KNOTS
CUBAN 8.....187 KNOTS	SINGLE SNAP ROLL.....96 KNOTS
IMMELMANN.....176 KNOTS	VERTICAL REVERSEMENT.....96 KNOTS
SLOW ROLL.....141 KNOTS	SPLIT 'S'.....79 KNOTS

AIRPEED LIMITATIONS

MAXIMUM LANDING GEAR EXTENDED SPEED	154 KNOTS
MAXIMUM DESIGN MANEUVER SPEED	145 KNOTS

SPIN ENTRY: STALL WITH POWER OFF, FLAPS UP, NOSE 15° ABOVE HORIZON, WITH FULL
UP ELEVATOR, APPLY FULL RUDDER IN THE DIRECTION OF DESIRED SPIN IMMEDIATELY PRIOR
TO STALL. IF AIRPLANE SPIRALS OR AIRSPEED EXCEEDS 115 KNOTS IAS,
INITIATE RECOVERY IMMEDIATELY.

NOTE: FOR LEFT SPINS APPLYAILERONS AGAINST (RIGHTAILERONS) AT THE
COMPLETION OF THE FIRST TURN AND HOLD UNTIL RECOVERY INITIATION.

SPIN RECOVERY: SIMULTANEOUSLY REVERSE RUDDER AND ELEVATOR WITH
AILERONS NEUTRAL. NEUTRALIZE ALL CONTROLS AS ROTATION STOPS.

FAA Approved

Revised: September, 1978

P/N 33-590006-13

**On Left Side Panel (Airspeed values are IAS):
(CJ-150 and after)**

THIS AIRPLANE MUST BE OPERATED IN COMPLIANCE WITH THE OPERATING LIMITATIONS STATED IN THE FORM OF PLACARDS, MARKINGS AND MANUALS.

REFER TO WEIGHT AND BALANCE DATA FOR LOADING INSTRUCTIONS. OCCUPIED SEATS MUST BE IN UPRIGHT POSITION DURING TAKE OFF AND LANDING. ALTITUDE LOSS DURING STALL RECOVERY: 300 FT. NO ACROBATIC MANEUVERS APPROVED EXCEPT THOSE LISTED BELOW.

UTILITY CATEGORY AIRPLANE

MAXIMUM WEIGHT 3000 LBS. FLIGHT MANEUVER LOAD FACTOR: FLAPS UP 4.0 G;
FLAPS DOWN 2.0 G.

MANEUVER	MAXIMUM ENTRY SPEED
CHANDLERS, LAZY EIGHTS, STEEP TURNS.....	124 KNOTS
STALLS (EXCEPT WHIP STALLS).....	SLOW DECELERATION

NOTE: INTENTIONAL SPINS PROHIBITED

AIRSPEED LIMITATIONS

MAX. LG. GEAR EXTENDED(NORMAL)	154 KTS	MAX. APPROACH FLAP (15°)	154 KTS
MAX. DESIGN MANEUVERING	124 KTS	MAX. FULL FLAPS (30°)	124 KTS

ACROBATIC CATEGORY AIRPLANE

MAXIMUM WEIGHT 2800 LBS. FLIGHT MANEUVER LOAD FACTOR: FLAPS UP 4.0 G, 3.0G;
FLAPS DOWN 3.0 G. CENTER OF GRAVITY BETWEEN STA. 78.3 AND STA. 81.0

CAUTION: INVERTED FLIGHT PROHIBITED. NEGATIVE G FLIGHT LIMITED TO 5 SECONDS OR LESS AS REQUIRED TO PERFORM APPROVED MANEUVERS. SEE ACROBATIC SUPPLEMENT TO PILOTS OPERATING HANDBOOK.

ACROBATIC BOOST PUMP MUST BE ON TO PERFORM THE FOLLOWING:

MANEUVER	MAXIMUM ENTRY SPEED		
CHANDLERS, LAZY EIGHT, STEEP TURNS.....	145 KNOTS		
STALLS AND SPINS.....	SLOW DECELERATION		
MANEUVER - RECOMMENDED ENTRY SPEED	RECOMMENDED ENTRY SPEED		
LOOP.....	167 KNOTS	BARREL ROLL.....	122 KNOTS
CURAN R.....	167 KNOTS	SINGLE SNAP ROLL.....	96 KNOTS
IMMELMANN.....	176 KNOTS	VERTICAL REVERSEMENT.....	96 KNOTS
SLOW ROLL.....	141 KNOTS	SPLIT 'S'.....	79 KNOTS

AIRSPEED LIMITATIONS

MAX. LG. GEAR EXTENDED(NORMAL)	154 KTS	MAX. APPROACH FLAPS (15°)	154 KTS
MAX. DESIGN MANEUVERING	143 KTS	MAX. FULL FLAPS (30°)	123 KTS

SPIN ENTRY: STALL WITH POWER OFF, FLAPS UP, NOSE 15° ABOVE HORIZON WITH FULL UP ELEVATOR, APPLY FULL RUDDER IN THE DIRECTION OF DESIRED SPIN IMMEDIATELY PRIOR TO STALL. IF AIRPLANE SPIRALS OR AIRSPEED EXCEEDS 115 KNOTS IAS, INITIATE RECOVERY IMMEDIATELY.

NOTE: FOR LEFT SPINS APPLY AILERONS AGAINST (RIGHT AILERON) AT THE COMPLETION OF THE FIRST TURN AND HOLD UNTIL RECOVERY INITIATION

SPIN RECOVERY: SIMULTANEOUSLY REVERSE RUDDER AND ELEVATOR WITH AILERONS NEUTRAL. NEUTRALIZE A14 CONTROLS AS ROTATION STOPS.

FAA Approved
Revised: September, 1978
P/N 33-58006-13

On Cabin Door Side Panel:

EMERGENCY EXIT

PULL HANDLE
PUSH OUT ON DOOR

REMOVE DOOR
HOLD-OPEN ROD PRIOR
TO OPERATION IN
ACROBATIC CATEGORY

On inside of Baggage Compartment Door:



BAGGAGE COMPARTMENT

LOAD IN ACCORDANCE WITH
WEIGHT AND BALANCE DATA

MAXIMUM STRUCTURAL CAPACITY - 270 POUNDS



EMERGENCY PROCEDURES

SPINS

If airplane spirals while attempting a spin or airspeed exceeds 115 knots IAS, immediately initiate recovery by simultaneously reversing both rudder and elevator controls with the ailerons neutral. Neutralize all controls as rotation stops.

EMERGENCY EXIT

To evacuate airplane, pull handle on Emergency Exit Door and push out.

NORMAL PROCEDURES

A constant power setting of 2500 RPM and 25 in. Hg or full-throttle is the most satisfactory power setting for all acrobatic maneuvers. The Auxiliary Fuel Pump Switch must be in the ACROBATIC BOOST position.

WARNING

Extended inverted flight (more than 5 seconds) is prohibited. This will result in a loss of oil pressure and a subsequent runaway propeller with possible blade separation. Warranties become invalid whenever violations of the above are apparent.

PERFORMANCE

No change

WEIGHT AND BALANCE

WEIGHING INSTRUCTIONS.

Periodic weighing of the Bonanza F33C may be required to keep the Basic Empty Weight current. All changes to the airplane affecting weight and balance are the responsibility of the airplane's operator.

1. Three jack points are provided for weighing: two on the wing front spar at Fuselage Station 83.1 and one on the aft fuselage at Fuselage Station 271.0.

FAA Approved
Revised: September, 1978
P/N 33-68006-13

2. Fuel should be drained preparatory to weighing. Tanks are drained from the regular drain ports with the airplane in static ground attitude. When tanks are drained, 1.5 pounds of undrainable fuel remain in the airplane at Fuselage Station 76.0. The remainder of the unusable fuel to be added to a Basic Empty Weight is 34.5 pounds at Fuselage Station 79.1.

3. Engine oil must be at the full level or completely drained. Total engine oil when full is 26 pounds at Fuselage Station 24.5. (Includes 3 pounds undrainable.)

4. To determine airplane configuration at time of weighing, installed equipment is checked against the airplane equipment list or superseding forms. All installed equipment must be in its proper place during weighing.

5. At the time of weighing, the airplane must be level both longitudinally and laterally, and the landing gear must be fully extended. Leveling screws are located on the left side of the fuselage at approximately Fuselage Station 152.25. Longitudinally level attitude is determined with a plumb bob. Laterally level attitude is obtained when the vertical distance from each wing tip to the floor is equal.

6. Measurement of the reaction arms for a wheel weighing is made using a steel measuring tape. Measurements are taken, with the airplane level on the scales, from the reference (a plumb bob dropped from the center of either main jack point) to the axle center line of the main gear and then to the nose wheel axle center line. The main wheel axle center line is best located by stretching a string across from one main wheel to the other. All measurements are to be taken with the tape level with the hangar floor and parallel to the fuselage center line. The locations of the wheel reactions will be approximately at Fuselage Station 96.7 for main wheels and Fuselage Station 12.7 for the nose wheel.

FAA Approved

Revised: September, 1978

P/N 33-590008-13

7. Jack point weighings are accomplished by placing scales on the jack points specified in step 1 above. Since the center of gravity of the airplane is forward of Fuselage Station 83.1, the tail reaction of the airplane will be in an up direction. This can be measured on regular scales by placing ballast of approximately 200 pounds on the scales to which the aft weighing point is attached by cable of adjustable length. The up reaction will then be total ballast weight minus the scale reading and is entered in the weighing form as a negative quantity.

8. Weighing should always be made in an enclosed area which is free from air currents. The scales used should be properly calibrated and certified.

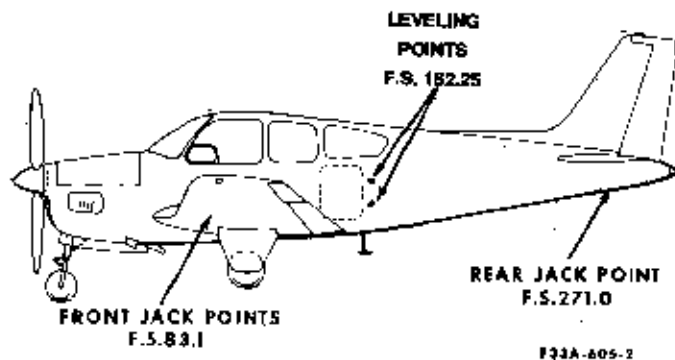

FAA Approved
Revised: September, 1978
P/N 33-590006-13

11 of 28

BASIC EMPTY WEIGHT AND BALANCE

BONANZA SER. NO. _____ REG. NO. _____ DATE _____
 STRUT POSITION - NOSE MAIN JACK POINT LOCATION PREPARED BY _____
 EXTENDED 11.8 96 FORWARD 83.1 Company _____
 COMPRESSED 13.1 97 AFT 271.0 Signature _____

REACTION - JACK POINTS	SCALE READING	TARE	NET WEIGHT	ARM	MOMENT
WHEEL - JACK POINTS					
LEFT MAIN					
RIGHT MAIN					
NOSE OR TAIL					
TOTAL (AS WEIGHED)					
Space below provided for additions and subtractions to be weighed condition					
EMPTY WEIGHT			26	-	638
ENGINE OIL			36	79	2844
UNUSABLE FUEL					
BASIC EMPTY WEIGHT					

FAA Approved

Revised: September, 1978

P/N 33-590006-13

NOTE

Each new airplane is delivered with a completed sample loading, basic empty weight and center of gravity, and equipment list, all pertinent to that specific airplane. It is the owner's responsibility to ensure that changes in equipment are reflected in a new weight and balance and in an addendum to the equipment list. There are many ways of doing this; it is suggested that a running tally of equipment changes and their effect on basic empty weight and CG is a suitable means for meeting both requirements.

That current equipment list and basic empty weight and CG information must be retained with the airplane when it changes ownership. Beech Aircraft Corporation cannot maintain this information; the current status is known only to the owner. If these papers become lost, the FAA will require that the airplane be re-weighed to establish the basic empty weight and CG and that an inventory of installed equipment be conducted to create a new equipment list.

LOADING INSTRUCTIONS

It is the responsibility of the airplane operator to ensure that the airplane is properly loaded. At the time of delivery, Beech Aircraft Corporation provides the necessary weight and balance data to compute individual loadings. All subsequent changes in airplane weight and balance are the responsibility of the airplane owner and/or operator.

The basic empty weight and moment of the airplane at the time of delivery are shown on the airplane Basic Empty Weight and Balance form. Useful load items which may be loaded into the airplane are shown on the Useful Load Weight and Moment tables. The minimum and maximum moments are indicated by the heavy border line on the Moment Limits vs Weight graph. These moments correspond to the forward and aft center of gravity flight limits for a particular weight. All moments are divided by 100 to simplify computations.

SEATING, BAGGAGE AND EQUIPMENT ARRANGEMENTS

PILOT & F. PASS	F.S.
FWD. POS.	85
AFT POS.	89
3RD & 4TH SEAT PASS	
FWD. POS.	121
AFT POS.	127

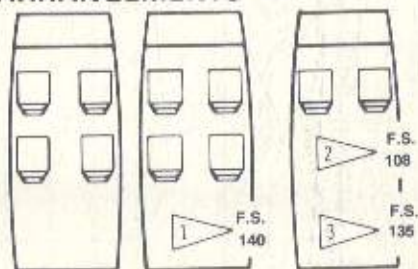

- 1 MAXIMUM WEIGHT 270 POUNDS INCLUDING EQUIPMENT AND BAGGAGE.
- 2 MAXIMUM WEIGHT 200 POUNDS FORWARD OF REAR SPAR INCLUDING EQUIPMENT AND CARGO WITH 3rd and 4th SEATS REMOVED.
- 3 MAXIMUM WEIGHT 270 POUNDS AFT OF REAR SPAR INCLUDING EQUIPMENT AND CARGO WITH 3rd and 4th SEATS REMOVED.

ALL BAGGAGE/CARGO MUST BE SECURED.

FAA Approved
Revised: September, 1978
P/N 33-590006-13

MOMENT LIMITS VS WEIGHT

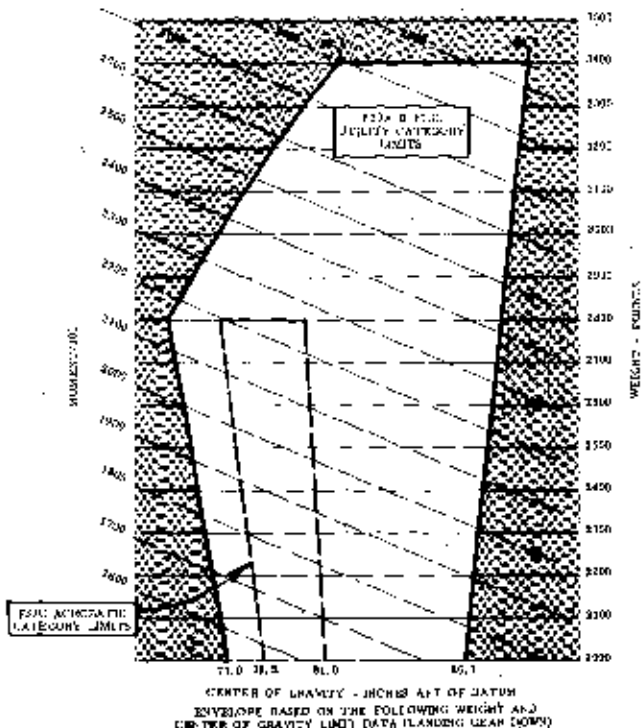

	WEIGHT LIMITATION	FORWARD C.G. LIMIT	AFT C.G. LIMIT
B7A & B7C UTILITY CATEGORY	3400 LB. (MAXIMUM TAKE-OFF OR LANDING)	81.1	86.7
	2600 LB. OR LESS	71.0	86.7
B7C ACROBATIC CATEGORY	2600 LB. OR LESS	78.5	81.0

FAA Approved
Revised: September, 1978
P/N 33-590008-13

COMPUTING PROCEDURE

1. Record the Basic Empty Weight and Moment from the Basic Empty Weight and Balance form (or from the latest superseding form) under the Basic Empty Condition block. The moment must be divided by 100 to correspond to Useful Load Weights and Moments tables.
2. Record the weight and corresponding moment from the appropriate table of each of the useful load items (except fuel) to be carried in the airplane.
3. Total the weight column and moment column. The SUB-TOTALS are the Zero Fuel Condition.
4. Determine the weight and corresponding moment for the fuel loading to be used. This fuel loading includes fuel for the flight, plus that required for start, taxi, and takeoff. Add the Fuel Loading Condition to Zero Fuel Condition to obtain the SUB-TOTAL Ramp Condition.
5. Subtract the fuel to be used for start, taxi, and takeoff to arrive at the SUB-TOTAL Take-off Condition.
6. Subtract the weight and moment of the fuel in the incremental sequence in which it is to be used from the take-off weight and moment. The Zero Fuel Condition, the Take-off Condition, and the Landing Condition moments must be within the minimum and maximum moments shown on the Moment Limit vs Weight graph for that weight. If the total moment is less than the minimum moment allowed, useful load items must be shifted aft or forward load items reduced. If the total moment is greater than the maximum moment allowed, useful load items must be shifted forward or aft load items reduced. If the quantity or location of load items is changed, the calculations must be revised and the moments rechecked.

FAA Approved
Revised: September, 1978
P/N 33-590006-13

**WEIGHT AND BALANCE LOADING FORM
(UTILITY & NORMAL CATEGORY)**

BONANZA F33C DATE 00/00/00
 SERIAL NO. CJ-XXX REG NO. NXXXX

ITEM	WEIGHT	MOM/100
1. BASIC EMPTY CONDITION	2255	1816
2. FRONT SEAT OCCUPANTS	340	288
3. 3rd and 4th SEAT OCCUPANTS	340	412
4. BAGGAGE	55	77
5. CARGO
6. CARGO
7. SUB TOTAL ZERO FUEL CONDITION	2990	2593
8. FUEL LOADING (25.3 GAL.)	422	316
9. SUB TOTAL RAMP CONDITION	3412	2909
10. *LESS FUEL FOR START, TAXI, AND TAKE-OFF	-12	-9
11. SUB TOTAL TAKE-OFF CONDITION	3400	2900
12. LESS FUEL TO DESTINATION (56 GAL.)	-336	-252
13. LANDING CONDITION	3064	2648

*Fuel for start, taxi and take-off is normally 12 lbs at an average mom:100 of 9.

FAA Approved
Revised: September, 1978
P/N 33-590006-13

19 of 28

**WEIGHT AND BALANCE LOADING FORM
(UTILITY & NORMAL CATEGORY)**

BONANZA _____ **DATE** _____
SERIAL NO. _____ **REG NO.** _____

ITEM	WEIGHT	MOM/100
1. BASIC EMPTY CONDITION		
2. FRONT SEAT OCCUPANTS		
3. 3rd and 4th SEAT OCCUPANTS		
4. BAGGAGE		
5. CARGO		
6. CARGO		
7. SUB TOTAL ZERO FUEL CONDITION		
8. FUEL LOADING		
9. SUB TOTAL RAMP CONDITION		
10. *LESS FUEL FOR START, TAXI, AND TAKE-OFF		
11. SUB TOTAL TAKE-OFF CONDITION		
12. LESS FUEL TO DESTINATION		
13. LANDING CONDITION		

*Fuel for start, taxi and take-off is normally 12 lbs at an average mom/100 of 9.

FAA Approved
Revised: September, 1978
P/N 33-590008-13

**WEIGHT AND BALANCE LOADING FORM
(ACROBATIC CATEGORY)**

BONANZA F33C DATE 00/00/00
 SERIAL NO. CJ-XXX REG NO. NXXXX

ITEM	WEIGHT	MOM/100
1. BASIC EMPTY CONDITION	2255	1816
2. REMOVE: 3rd & 4th SEATS (IF REQUIRED)	-50	-63
3. REVISED BASIC EMPTY CONDITION	2205	1753
4. PILOT	190	162
5. STUDENT PILOT	190	162
6. SUB TOTAL ZERO FUEL CONDITION	2585	2077
7. FUEL LOADING (37.5 GAL)	227	170
8. SUB TOTAL RAMP CONDITION	2812	2247
9. LESS FUEL FOR START, TAXI, AND TAKE-OFF	-12	-9
10. SUB TOTAL TAKE-OFF CONDITION	2800	2238
11. LESS FUEL TO DESTINATION (22 GAL.)	132	-99
12. LANDING CONDITION	2668	2139

*Fuel for start, taxi and take-off is normally 12 lbs at an average mom/100 of 9.

FAA Approved
Revised: September, 1978
P/N 33-590006-13

21 of 28

**WEIGHT AND BALANCE LOADING FORM
(ACROBATIC CATEGORY)**

BONANZA _____ DATE _____
 SERIAL NO. _____ REG NO. _____

ITEM	WEIGHT	MOM/100
1. BASIC EMPTY CONDITION		
2. REMOVE: 3rd & 4th SEATS (IF REQUIRED)		
3. REVISED BASIC EMPTY CONDITION		
4. PILOT		
5. STUDENT PILOT		
6. SUB TOTAL ZERO FUEL CONDITION		
7. FUEL LOADING		
8. SUB TOTAL RAMP CONDITION		
9. *LESS FUEL FOR START, TAXI, AND TAKE-OFF		
10. SUB TOTAL TAKE-OFF CONDITION		
11. LESS FUEL TO DESTINATION		
12. LANDING CONDITION		

*Fuel for start, taxi and take-off is normally 12 lbs at an average mom/100 of 9.

FAA Approved
Revised: September, 1978
P/N 33-590006-13

USEFUL LOAD WEIGHTS AND MOMENTS

WEIGHT	OCCUPANTS					
	FRONT SEATS			3RD & 4TH SEATS		
	FWD. POSITION ARM 85	AFT POSITION ARM 89	MOMENT/100	FWD. POSITION ARM 121	AFT POSITION ARM 127	MOMENT/100
120	102	107	145	152		
130	110	116	157	165		
140	119	125	169	178		
150	128	134	182	190		
160	136	142	194	203		
170	144	151	206	216		
180	153	160	218	229		
190	162	169	230	241		
200	170	178	242	254		

NOTE: Occupant Positions for Adjustable Seats are shown at their extreme positions. Intermediate Positions will require interpolation of the Moment/100 Values.

USEFUL LOAD WEIGHTS AND MOMENTS

USABLE FUEL

LEADING EDGE TANKS
ARM 75

GALLONS	WEIGHT	MOM/100	GALLONS	WEIGHT	MOM/100
5	30	23	44	264	198
10	60	45	50	300	225
15	90	68	55	330	248
20	120	90	60	360	270
25	150	113	65	390	293
30	180	135	70	420	315
35	210	158	74	444	333
40	240	180			

CARGO (With 3rd & 4th Seats Removed)			
AHEAD OF SPAR ARM 108		AFT OF SPAR ARM 135	
Weight	Moment	Weight	Moment
	100		100
20	22	20	27
40	43	40	54
60	65	60	81
80	86	80	108
100	108	100	135
120	130	120	162
140	151	140	189
160	173	160	216
180	194	180	243
200	216	200	270
		220	297
		240	324
		260	351
		270	364

FAA Approved
Revised: September, 1978
P/N 33-690008-13

**BAGGAGE
ARM 140**

Weight	Moment	Weight	Moment
	100		100
10	14	130	182
20	28	140	196
30	42	150	210
40	56	160	224
50	70	170	238
60	84	180	252
70	98	190	266
80	112	200	280
90	126	210	294
100	140	220	308
110	154	230	322
120	168	240	336
		250	350
		260	364
		270	378

SYSTEMS

SEATS, SEAT BELTS, AND SHOULDER HARNESS (CJ-149 and After, and Airplanes Incorporating Kit No. 33- 6004-1)

SEAT ADJUSTMENTS

To adjust any of the four seats forward or aft, pull up on the release bar below each seat and slide the seat to the desired position. All the seat backs can be placed in four positions by actuating a release lever on the inboard side of each seat. All seats are equipped with a locking back to accommodate the shoulder harness. The seat backs can be folded over by rotating the red handle on the lower inboard side of the seat. An additional lever, located behind the copilot's seat on the upper right corner, is also used to fold the copilot's seat forward for access to the rear seats. An option is available that provides for the copilot and the third and fourth place seats to be positioned from vertical to fully reclined. Adjustable headrests are provided for all seats. Outboard armrests for all seats are built into the cabin side walls. Center armrests can be elevated or positioned flush with the seat cushions.

SHOULDER HARNESS

The shoulder harness is installed on all four seats and should be used with seats in the upright position during takeoff and landing. The shoulder harness straps are attached to an inertia reel mounted to the lower back portion of each seat back and covered by the seat upholstery. The pilot's and copilot's shoulder harness belt is in the "Y" configuration with the single strap attached to the inertia reel. The two straps are worn with one strap over each shoulder and routed down to the seat belt. The seat belt link is inserted through both of

FAA Approved
Revised: September, 1976
P/N 33-690006-13

27 of 28

the shoulder strap loop links and into the seat belt buckle. The passenger shoulder harness strap is attached to the inertia reel and routed over the outboard corner of the seat. The strap is routed over the shoulder and chest and secured with a button type hook to the seat belt.

The shoulder harness inertia reels on the pilot's and copilot's seats are locked or unlocked by positioning the inertia reel control handle located inboard on each seat. The handle is spring loaded to either the locked or automatic position. When the handle is in automatic (aft) position, spring loading of the inertia reel maintains a slight tension on the harness but permits the pilots to make normal movements in flight. If the inertia reel should lock while in automatic, the handle must be pushed forward and then aft to unlock. When the handle is moved to the locked (forward) position, the inertia reel locks the harness to successive positions as the pilot leans back. Before the inertia reel can be unlocked, all tension must be removed from the harness by leaning full back in the seat. Spring loading at the inertia reels on the third and fourth seats keeps the harness snug but will allow normal movement during flight. The inertia reel on all seats is designed with a locking device that will secure the harness in the event of sudden forward movement or an impact action.

When the airplane is used for acrobatics and parachutes are worn, the headrests for the pilot's and copilot's seats must be removed, the seat back cushions rotated over the seat backs and reattached to the bottom of the seat backs, and the headrest reinstalled.

Approved:

Donald St. Peter
for Chester A. Rembleske
Beech Aircraft Corporation
DOA CE-2

FAA Approved

Revised: September, 1978

P/N 33-59006-13

**BEECHCRAFT S35, V35, V35A, V35B, 35-C33,
E33, F33, F33A, F33C, G33 AND A36 LANDPLANES**

**PILOT'S OPERATING HANDBOOK AND
FAA APPROVED AIRPLANE FLIGHT MANUAL
SUPPLEMENT
for the
LANDING GEAR SAFETY SYSTEM**

GENERAL

This document is to be attached to the Pilot's Operating Handbook and FAA Approved Airplane Flight Manual when the airplane is equipped with the Landing Gear Safety System which has been installed in accordance with BEECHCRAFT FAA approved data.

This document supersedes or adds to the Pilot's Operating Handbook and FAA Approved Airplane Flight Manual only where covered in the items contained herein.

LIMITATIONS

The landing gear safety system is designed to help prevent "gear-up" landings and premature or inadvertent operation of the landing gear mechanism. The system is to be used as safety backup device only; normal usage of the landing gear position switch is mandatory.

EMERGENCY PROCEDURES

In the event of an emergency, automatic extension of the landing gear may be prevented by placing the landing gear safety system switch in the OFF position, thus inactivating the safety system.

**FAA Approved
Revised: October, 1976
P/N 35-590110-13**

NORMAL PROCEDURES

PREFLIGHT CHECK:

1. Throttle - CLOSED OR RETARDED.
2. Battery master switch - ON
3. Landing gear circuit breaker - either IN or OUT.
4. (Airplanes incorporating the on-off and test function in one switch.)
Place the ON-OFF-TEST switch in the TEST position. Proper functioning of the automatic landing gear extension portion of the system is indicated by the noise or movement of the solenoid in the landing gear position switch. The ON-OFF-TEST switch returns normally to the ON position unless the pilot places the switch in the OFF position.
5. (Airplanes equipped with on-off and press-to-test switches.)
Place the ON-OFF switch in the "ON" position and push the PRESS-TO-TEST. Proper functioning of the automatic landing gear extension portion of the system is indicated by the noise or movement of the solenoid in the landing gear position switch. The PRESS-TO-TEST switch will not operate the solenoid unless the on-off switch is in the "ON" position.
6. Landing gear circuit breaker - IN before takeoff.

OPERATION

1. Landing Gear Extension - With the landing gear safety system switch in the ON position the landing gear will be automatically extended when: (1) the airspeed is below approximately 104 kts/120 mph IAS and (2) the engine is

FAA Approved

Revised: October, 1976

P/N 35-590110-13

operating at a throttle position corresponding to approximately 18 to 20 inches or less of manifold pressure depending on setting.

2. Landing Gear Retraction - With the landing gear safety system switch in the ON position, the landing gear will not retract unless: (1) the landing gear position switch is in the UP position (2) the airspeed is above approximately 78 kts/90 mph IAS and (3) the engine is operating at a throttle position corresponding to approximately 18 to 20 inches or more of manifold pressure depending on setting.

NOTE

If landing gear retraction is desired before the indicated airspeed reaches approximately 78 kts/90 mph, the landing gear safety system must be inactivated by placing the switch in the OFF position, preferably before placing the landing gear position switch in the UP position.

PERFORMANCE

No change

Approved:



for Chester A. Rembleske
Beech Aircraft Corporation
DOA CE-2

FAA Approved
Revised: October, 1976
P/N 35-590110-13

3 of 3

**BEECHCRAFT F33A, F33C, G33, V35B,
and A36 LANDPLANES**

**PILOT'S OPERATING HANDBOOK AND
FAA APPROVED AIRPLANE FLIGHT MANUAL
SUPPLEMENT
for the
KING KN-74 AREA NAVIGATION SYSTEM**

GENERAL

The information in this supplement is FAA approved material and must be attached to the Pilot's Operating Handbook and FAA Approved Airplane Flight Manual when the airplane is equipped with a King KN-74 Area Navigation System which has been installed in accordance with BEECHCRAFT FAA approved data.

The information in this supplement supersedes or adds to the basic Pilot's Operating Handbook and FAA Approved Airplane Flight Manual only as set forth below.

LIMITATIONS

1. This system shall not be used as a primary system under IFR conditions except on approved approach procedures, approved area navigation airways, and random area navigation routes when approved by Air Traffic Control.
2. This system is to be used only with colocated facilities (VOR and DME signals originate from the same geographic location).

**FAA Approved
Revised: October, 1976
P/N 35-590118-13**

1 of 3

EMERGENCY PROCEDURES

CAUTION

DME may unlock due to loss of signal with certain combinations of distance from station, altitude, and angle of bank.

1. VOR or Distance flag appears while in RNAV mode:
 - a. Selected Frequency - CHECK FOR CORRECT FREQUENCY
 - b. VOR or Distance flag intermittent or lost - UTILIZE OTHER NAVIGATION EQUIPMENT AS REQUIRED.
2. VOR or Distance flag appears while in APPR mode:

If flag appears **while** on an approach, execute a missed approach and utilize another approved facility.

NORMAL PROCEDURES

1. VHF NAV - ON
2. DME - ON
3. Mode Selector - SELECT VOR/DME, RNAV, or APPR
4. NAV Frequency - SET
5. DME Frequency - SET
6. Waypoint Bearing - SET WAYPOINT RADIAL FROM VORTAC
7. Waypoint Distance - SET WAYPOINT DISTANCE FROM VORTAC
8. OBS Control - DESIRED MAGNETIC COURSE
9. Self-Test - ACTUATE (must have VOR reception)

FAA Approved
Revised: October, 1976
P/N 35-590118-13

PERFORMANCE

No change.

Approved:



for

Chester A. Rembleske
Beech Aircraft Corporation
DOA CE-2

FAA Approved
Revised: October, 1976
P/N 35-590118-13

3 of 3

**BEECHCRAFT H35, J35, K35, M35, N35, P35,
S35, V35, V35A, V35B, 33, A33, B33, C33,
E33, F33, F33A, F33C, G33, and A36
LANDPLANES**

**PILOT'S OPERATING HANDBOOK AND
FAA APPROVED AIRPLANE FLIGHT MANUAL
SUPPLEMENT
for the
STANDBY GENERATOR POWER SYSTEM
(14-VOLT ELECTRICAL SYSTEM)**

GENERAL

The information in this supplement is FAA approved material and must be attached to the Pilot's Operating Handbook and FAA Approved Airplane Flight Manual when the airplane is equipped with a factory installed Standby Generator Power System in accordance with BEECHCRAFT FAA approved data, or if the system is installed by kit, in accordance with BEECH KIT 35-3012.

The information in this supplement supersedes or adds to the basic Pilot's Operating Handbook and FAA Approved Airplane Flight Manual only as set forth below.

LIMITATIONS

1. The system is to be used only in the event of an alternator failure.
2. Maintain a minimum of 2300 RPM during system operation.

**FAA Approved
Revised: September, 1978
P/N 35-590118-19**

1 of 4

EMERGENCY PROCEDURES

1. With a loss of electrical power from the alternator, turn the Battery and Alternator Switches - OFF
2. Turn Standby Generator System - ON
3. If RNAV is installed - Select NAV/COMM II position.
4. The factory installed standby Generator Power System will operate ONLY the following items:
 - a. Engine Instruments and Fuel Gages
 - b. Electric Turn Coordinator
 - c. Transponder (if installed)
 - d. Audio Amplifier (if installed)
 - e. If RNAV is not installed: NAV/COMM I or NAV/COMM II (only one at a time)
 - f. If RNAV is installed: COMM I or NAV/COMM II (only one at a time)

NOTE

If an electric compass system is installed and the standby generator system is in operation, no directional gyro indication will be available unless a second air driven directional gyro is installed.

5. The kit installed Standby Generator Power System will operate ONLY the following items. Marked X:

FAA Approved
Revised: September, 1978
P/N 35-590118-19

- Engine Instruments and Fuel Gages
- Electric Turn Coordinator
- Transponder (if installed)
- Audio Amplifier (If installed)
- If RNAV is not installed: NAV/COMM I or NAV/COMM II (only one at a time)
- If RNAV is installed: COMM I or NAV/COMM II (only one at a time)

NOTE

If an electric compass system is installed and the standby generator system is in operation, no directional gyro indication will be available unless a second air driven directional gyro is installed.

-
- 6. Failure of a NAV/COMM, all other instruments operable.
 - a. If RNAV is not installed: select other NAV/COMM (if installed)
 - b. If RNAV is installed: select COMM I.
 - 7. Failure of any one instrument indicates a malfunction in that system only.
 - 8. Failure of all instruments indicates a malfunction of the Standby Generator System.
 - a. Standby Generator Switch - OFF
 - b. Reduce Electrical Load
 - c. Battery Switch - ON (if available)

FAA Approved
Revised: September, 1978
P/N 35-590118-19

3 of 4

- 9. When the Standby Generator System is in use, the Landing Gear must be extended manually.

NORMAL PROCEDURES

In the Before Take-Off Check List the Standby Generator TEST procedure follows the Magneto Check...

1. Throttle - 1700 RPM
2. Battery and Alternator Switches - OFF

NOTE

If either the BAT-GEN lights fail to illuminate, it indicates a malfunction in that part of the system. Check operation of components listed under step "5" of EMERGENCY PROCEDURES to ensure system is functioning properly.

3. Standby Generator Power ON-OFF-TEST Switch TEST (Hold Momentarily in Test Position, BAT-GEN lights will illuminate.)
4. Standby Generator Power ON-OFF-TEST Switch-OFF
5. Battery and Alternator Switches - ON

PERFORMANCE - No Change

Approved:

Donald H. Peter
For Chester A. Rembleske
Beech Aircraft Corporation
DOA CE-2

FAA Approved

Revised: September, 1978

P/N 35-590118-19

**BEECHCRAFT BONANZA S35, V35, V35A, V35B, F33A,
F33C AND A36 LANDPLANES**

**PILOT'S OPERATING HANDBOOK AND FAA APPROVED
AIRPLANE FLIGHT MANUAL SUPPLEMENT**

**for the
ELECTROTHERMAL PROPELLER DEICE
(2 and 3 Bladed Propeller)
(14-Volt Electrical System)**

GENERAL

The information in this supplement is FAA approved material and must be attached to the Pilot's Operating Handbook and FAA Approved Airplane Flight Manual when the airplane is equipped with an Electrothermal Propeller Deice System that has been installed in accordance with BEECHCRAFT FAA approved data, or if the system is installed by kit, in accordance with Beech Kit 35-9001, 35-9003, or 35-9005.

LIMITATIONS

Do not operate the system unless engine is operating.

PLACARDS

On Instrument Panel:

**TO PREVENT ELECTRICAL OVERLOAD
OPERATE THE PROPELLER DEICE
SYSTEM ONLY IF THE ELECTRICAL
LOAD HAS BEEN MONITORED PER
THE ELECTRICAL EQUIPMENT LIST IN
THE FLIGHT MANUAL SUPPLEMENT**

**FAA Approved
Revised: November, 1977
P/N 35-590118-25**

ELECTRICAL EQUIPMENT LIST

(While Deice System is in use)

The following list specifies the electrical equipment items that may be operating when using the Propeller Deice System under various flight conditions. Standard electrical items (such as navigation and panel lights) and items normally used only for short periods (such as taxi light, landing light, and landing gear) are not listed, but may be operated whenever required.

NOTE

Items are listed as factory equipped. Any change in equipment will require changes to this list.

LIST OF EQUIPMENT	VFR		IFR	
	DAY	NIGHT	DAY	NIGHT

WARNING

This airplane may not be operated in a Terminal Controlled Area under VFR or IFR night conditions when propeller deice system is operating. Items installed on the airplane that are not shown on the above equipment list will overload the electrical system, possibly causing alternator failure.

FAA Approved

Revised: November, 1977

P/N 35-590118-25

EMERGENCY PROCEDURES

1. Loss of Alternator
 - a. Propeller Deice Switch - Off
2. Abnormal Reading on Propeller Deice Ammeter
 - a. Zero Amps

Check propeller deice switch. If the circuit breaker in the switch has tripped, a wait of approximately 30 seconds is necessary before resetting the switch to the ON position. If ammeter reads 0 and switch has not tripped or if ammeter still reads 0 after the switch has been reset, turn the switch off and consider the propeller deice system inoperative.

- b. Zero to 20 Amps (2 Blade)
Zero to 30 Amps (3 Blade)

If propeller deice system ammeter occasionally or regularly indicates less than 20 amps (2 blade), 30 amps (3 blade), operation of the propeller deice system can continue unless serious propeller imbalance results from irregular ice throw-offs.

- c. More than 24 Amps (2 Blade)
More than 34 Amps (3 Blade)

If the propeller deice system ammeter occasionally or regularly indicates more than 24 amps (2 blade), 34 amps (3 blade), the system should not be operated unless the need for propeller deice is urgent.

NORMAL PROCEDURES

PREFLIGHT

1. With engine operating, place propeller deice switch in the ON position.
2. Check propeller deice system ammeter for reading of 20 to 24 amperes (2 blade), 30 to 34 amperes (3 blade).

IN FLIGHT

1. Follow the placarded procedure to monitor electrical load.
2. To place the system in operation, move propeller deice switch to the ON position. The system will function automatically until the switch is turned off.

CAUTION

The system is not to be operated continuously due to its electrical load.

3. Propeller imbalance may be relieved by varying rpm. Increase rpm briefly and return to desired setting, repeating if necessary.

PERFORMANCE - No Change

Approved:

for *Donald St. Peter*

Chester A. Rembleske
Beech Aircraft Corporation
DOA CE-2

FAA Approved

Revised: November, 1977

P/N 35-590118-25

**BEECHCRAFT F33A, V35B,
AND A36 LAND PLANES**

**PILOT'S OPERATING HANDBOOK AND
FAA APPROVED AIRPLANE FLIGHT MANUAL
SUPPLEMENT
for the
AIR CONDITIONING SYSTEM**

GENERAL

The information in this supplement is FAA approved material and must be attached to the Pilot's Operating Handbook and FAA Approved Airplane Flight Manual when the airplane is equipped with an Air Conditioning System, which has been installed in accordance with BEECHCRAFT FAA approved data.

The information in this supplement supersedes or adds to the basic Pilot's Operating Handbook and FAA Approved Airplane Flight Manual only as set forth below.

LIMITATIONS

The air conditioning system must be off during takeoff. The AIR COND. CONDENSER EXT. warning light must be extinguished (condenser retracted) before takeoff.

The air conditioning system must be off when using magnetic compass.

PLACARDS

On Glareshield:



FAA Approved
Revised: November, 1977
P/N 35-590118-35

On Control Console:

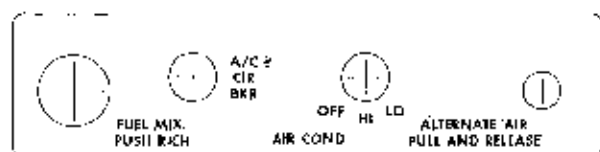

*Located on copilot's subpanel in airplanes with 28-volt electrical system

On Lower Edge of Floating Panel:



EMERGENCY PROCEDURES

AIR START PROCEDURE

Air conditioning system must be turned off before attempting air start procedures.

AIR CONDITIONING SYSTEM MALFUNCTION

Turn off air conditioning system.

If air conditioning system circuit breaker trips, do not reset until the cause of the malfunction has been determined and corrected.

NORMAL PROCEDURES

PREFLIGHT INSPECTION

NOSE SECTION

Air Conditioner Condenser - CHECK SECURITY AND ATTACHMENT.

FAA Approved
Revised: November, 1977
P/N 35-590118-35

STARTING

Air conditioner may be on as desired after engine start for cabin cooling before takeoff.

BEFORE TAKEOFF

WARNING

Air conditioner condenser extended warning light, located on the lower edge of the floating panel, must be off before takeoff.

Air conditioning system must be turned off before takeoff. After landing gear is retracted and airplane is clear of all obstacles, air conditioning system may be turned on as desired.

SHUTDOWN

Turn off air conditioner before engine shutdown.

PERFORMANCE

CRUISE PERFORMANCE

NOTE

Using the power settings given in the PERFORMANCE section, with the air conditioner in operation, Range and airspeed will decrease by approximately 5% due to the extension of the condenser to the flight extension position. This is to be taken into consideration during flight planning.

FAA Approved
Revised: November 1977
P/N 35-590118-35

SYSTEMS DESCRIPTION

Cabin cooling is provided by a 12,000 Btu, 30-cfm, refrigerative type air conditioning system. The principal components of the air conditioning system are the compressor and clutch unit (bolt-driven from a drive pulley on the engine), the retractable condenser on the center line of the fuselage bottom skin, the dehydrator beneath the right front seat, the evaporator module beneath the left front seat, the air conditioner condenser-extended warning light on the lower edge of the floating panel, the various retractable condenser limit switches, the system controls on the control console, and the circuit breaker. The circuit breaker is located on the control console in airplanes with the 14-volt system and on the right subpanel on airplanes with the 28-volt system.

The three-position retractable condenser is operated by an electric motor and jackscrew actuator, and controlled by two internal stops in the motor, two limit switches on the condenser, the landing gear safety switch, and a throttle limit switch. The three retractable condenser positions are ground extension, flight extension, and retracted.

When the airplane is on the ground and the air conditioner is turned on, the condenser extends to the ground extension (lowest) position below the fuselage bottom to facilitate condenser cooling by ambient air from the propeller slipstream. More effective cooling on the ground can be accomplished by maintaining a propeller setting of at least 1200 rpm with the airplane nosed into the wind. With the condenser in the ground extension position, the air conditioner condenser-extended warning light on the lower edge of the floating panel is illuminated.

When the airplane is in flight with the landing gear retracted and the air conditioner is turned on, the condenser extends only to the flight extension position. The flight extension position produces less drag than the ground extension

FAA Approved

Revised: November, 1977

P/N 35-590118-35

position, but provides adequate condenser cooling from the airstream. The air conditioner condenser-extended warning light is not illuminated in the flight extension position.

When the air conditioner is turned off, the condenser returns to the retracted position, the position which produces minimum drag.

For cooling, cabin air is drawn into the evaporator module plenum below the forward edge of the left front seat. When cabin ambient air at a temperature of approximately 90° F passes over the evaporator coils the temperature of the air is reduced to approximately 56°F, then the evaporator module electric blower forces the cooled air through outlet ducting to adjustable louvers below the control console. The cabin air continues to circulate as described until the air conditioner is turned off.

After engine start the air conditioner may be turned on by actuating a three-way toggle switch on the control console below the center of the upper subpanel. Either a high or a low blower speed may be selected, and the airflow can be distributed by moving the adjustable louvers up and down and from side to side.

Before takeoff make certain that the air conditioner is off and that the air conditioner condenser-extended warning light is extinguished. Pressing the warning light test button on the instrument panel will verify that the bulb is functioning.

After takeoff with the landing gear retracted and the airplane clear of all obstacles, the air conditioner may be turned on if desired.

The air conditioner should be turned off before engine shutdown.

FAA Approved
Revised: November, 1977
P/N 35-590118-35

The throttle limit switch is a safety device designed to operate only at full throttle with the landing gear extended, and is installed on the engine throttle body. When the air conditioner is on during landing approach with the landing gear extended and partial throttle, the condenser is in the flight extension position. However, should a go-around be necessary, the application of full throttle will cause the throttle limit switch to shut down the compressor for maximum engine power and retract the condenser to the retracted position to minimize drag. When the landing gear is retracted and/or the throttle is retarded, the compressor will resume operation and the condenser will return to the flight extension position.

Approved:

for *Donald St. Peter*
Chester A. Rembleske
Beech Aircraft Corporation
DOA CE-2

**BEECHCRAFT LANDPLANES F33A, V35B, A36, AND
A36TC**

**PILOT'S OPERATING HANDBOOK AND
FAA APPROVED
AIRPLANE FLIGHT MANUAL SUPPLEMENT**

for the

COLLINS ANS-351 AREA NAVIGATION SYSTEM

GENERAL

The information in this supplement is FAA approved material and must be attached to the *Pilot's Operating Handbook and FAA Approved Airplane Flight Manual* when the airplane has been modified by installation of the Collins ANS-351 Area Navigation System in accordance with Beech FAA Approved Data.

The information in this supplement supersedes or adds to the basic *Pilot's Operating Handbook and FAA Approved Airplane Flight Manual* only as set forth within this document. Users of the manual are advised always to refer to the supplement for possibly superseding information and placarding applicable to operation of the airplane.

LIMITATIONS

1. The Area Navigation function may not be used as a primary system under IFR conditions except on approved approach procedures, approved area navigation airways, and random area navigation routes when approved by Air Traffic Control.
2. The Area Navigation function can only be used with collocated facilities. (VOR and DME signals originate from the same geographical location.)

FAA Approved
Revised: December 1978
P/N 33-590009-19

3. The maximum distance for waypoint location is 199 nautical miles from the VOR/DME facility.
4. Approach mode should be restricted to distance of 50 nautical miles or less from the waypoint in use.

EMERGENCY PROCEDURES

CAUTION

DME may unlock due to loss of signal with certain combinations of distance from station, altitude, and angle of bank.

1. If NAV flag appears while in the enroute mode, check for correct frequency.
2. If VOR or DME equipment is intermittent or lost, utilize other navigation equipment as required.
3. If NAV flag appears during an approach, execute published missed approach and utilize another approved facility.

NORMAL PROCEDURES

1. NAV receivers - ON
2. Presetting waypoints on the ground:

NOTE

When power is first applied to the ANS-351 and the system is in the RNAV mode, WPT 1 will be active and waypoint bearing and distance indicators will read zero.

FAA Approved
Revised: December 1978
P/N 33-590009-19

NORMAL PROCEDURES

- a. WPT 1 coordinates are set into the ANS-351 using the concentric knobs under the bearing and distance display fields.
 - b. The waypoint selection knob is then rotated to select WPT 2. Note that the waypoint number is blinking, indicating that the waypoint is inactive at this point. WPT 2 bearing and distance definitions are then set into the ANS-351.
 - c. Set up the rest of the desired waypoints as described above. The ANS-351 has memory capacity for 8 waypoints.
 - d. Press the RTN (return) push button to display the active waypoint.
3. Changing waypoints in flight:
- a. Select heading mode on the autopilot if engaged.
 - b. Rotate the waypoint selector until the desired waypoint number and coordinates are displayed.
 - c. Verify that the new waypoint definition is correct by comparing the display to the flight plan.
 - d. Select the desired reference frequency on the associated navigation receiver and positively identify by listening to the "ident" tone.
 - e. Select the desired course on the OBS (Omni Bearing Selector).

NORMAL PROCEDURES (Cont.)

- f. Press the USE button on the ANS-351 and note that the waypoint identification number stops blinking.
 - g. Select the NAV mode on the autopilot after the deviation and distance-to-waypoint indications have stabilized.
4. Presetting waypoints in flight (RNAV mode):

Waypoints may be preset in flight without disturbing the navigational outputs.

- a. Rotate the waypoint selector knob to display the waypoint number to be preset. Note blinking waypoint number.
 - b. Set into the ANS-351 the desired waypoint bearing and distance.
 - c. Press the RTN (return) push button and note that the presently used waypoint is displayed.
5. Presetting waypoint in flight (VOR/LOC modes):

If the system is in VOR or LOC mode the ANS-351 will annunciate these modes on the display.

- a. Rotate the waypoint selector knob and note that the VOR or LOC annunciator is replaced by waypoint number, bearing, and distance. The waypoint number will always be blinking and the USE push button will be inactive.
- b. Preset the waypoint bearing and distances.

FAA Approved
Revised: December 1978
P/N 33-590009-19

- c. Press the RTN (return) push button and observe the annunciation of VOR or LOC on the ANS-351 panel.

PERFORMANCE

No change.

SYSTEM DESCRIPTION

1. Navigation System Mode Control - A four position switch, located on the instrument panel or DME control head, is used to select the navigational mode of operation, either RNAV or VOR.

2. The Collins DME indicator used with the computer in the RNAV mode displays distance to the active waypoint in nautical miles, time to the waypoint in minutes, and all angle ground speed in knots (i.e. the airplane does not have to be on a course directly to a waypoint to display a valid groundspeed). A green annunciator light on the indicator is illuminated any time the system is in the RNAV mode and power is applied to the NAV receiver.

After initiating the RNAV mode, always observe the ground speed over a period of 2 minutes or more to ensure that the indication has reached a steady-state value.

3. ANS-351 Area Navigation Computer
 - a. Collins Mode Control (ENR/APPR) - Use of this control allows selection of either ENR (enroute) or APPR (approach) modes of operation. In the enroute mode the course devia-

SYSTEM DESCRIPTION (Cont.)

tion is 5 nautical miles full scale. In the approach mode the course deviation is 1.25 nautical miles full scale deflection of the CDI, (Course Deviation Indicator).

- b. Waypoint Selector (WPT) - Sequences display waypoints from 1 through 8. Winking waypoint number indicates nonactive waypoints; steadily on waypoint number indicates the active waypoint.
- c. Radial Selector - Two concentric knobs can be used to set radial information into the display. Knobs control information as follows:

Large knob: Changes the display in 10-degree increments.

Small knob, pushed in: Changes the display in 1-degree increments.

Small knob, pulled out: Changes the display in 0.1-degree increments.

- d. Distance Selector - Two concentric control knobs can be used to set distance information in nautical miles into the display.

Knobs control information as follows:

Large knob: Changes the display in 10-nautical mile increments.

FAA Approved
Revised: December 1978
P/N 33-590009-19

Small knob, pushed in: Changes the display in 1-nautical mile increments.

Small knob, pulled out: Changes the display in 0.1-nautical mile increments from 00.0 through 100 miles. Beyond 100 NM, changes the display in 1-mile increments.

- e. Return Button (RTN) - Pressing RTN returns the display to the active waypoint when a nonactive waypoint is currently being displayed.
- f. Use Button (USE) - Pressing the USE button converts the waypoint being displayed into the active waypoint.
- g. Check Button (CHK) - Pressing the CHK button causes normal slant range DME distance to the VOR/DME station to be presented on the DME indicator. The WPT annunciator on the DME indicator will extinguish during this time. If TO or FROM is selected on the Collins NAV receiver, the magnetic bearing to or from the VOR/DME station will be displayed. The WPT annunciator light on the NAV receiver will extinguish during the time the CHK button is held down. If an RMI is installed, and is compatible with the ANS-351, pressing the check button will cause the bearing pointer to indicate the bearing to the active VOR station. RNAV computation, CDI deviation, TO/FROM display, and autopilot tracking of RNAV path

SYSTEM DESCRIPTION (Cont.)

remain unaffected. The check button is spring loaded to prevent prolonged actuation.

- h. Ambient Light Sensor - Automatically adjusts display lighting intensity as a function of cockpit ambient light.
4. Collins Navigation Receiver (NAV).
- a. OFF - Controls power to the NAV receiver and to the Area Navigation Computer.
 - b. FREQ - Allows the selection of VOR and Localizer frequencies.
 - c. TO - Displays airplane magnetic bearing to the VOR station in the normal mode and airplane magnetic bearing to the waypoint in the RNAV mode.
 - d. FROM - Displays airplane magnetic bearing from the VOR station in the normal mode, and airplane bearing from the waypoint in the RNAV mode.
 - e. WPT Annunciator - Light is illuminated any time the NAV receiver is on, the RNAV mode is selected, and CHK button is not depressed.
 - f. Ambient Light Sensor - Automatically adjusts display lighting intensity as a function of cockpit ambient light.
5. CDI (Course Deviation Indicator)
- a. Operation of the CDI in the RNAV mode differs from the operation in the VOR mode as follows:

FAA Approved

Revised: December 1978

P/N 33-590009-19

1. Indicator movement represents a linear deviation from the selected course.
2. In the enroute mode, full scale deviation is 5 NM. In the approach mode, the full scale deflection is 1.25 NM.
3. An annunciator light on the instrument panel illuminates any time power is applied to the NAV receivers and the system is in the RNAV mode.

6. RMI Bearing

An output is provided by the ANS-351 that allows an RMI with built-in NAV converter to display bearing to or from the waypoint while operating in the RNAV mode. (NOTE: An RMI may or may not be installed to work in conjunction with the RNAV computer).

Approved:

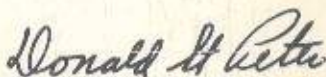

For

W. H. Schultz
Beech Aircraft Corporation
DOA CE-2

**BEECHCRAFT LANDPLANES
V35B, F33A, F33C, and A36**

**PILOT'S OPERATING HANDBOOK AND
FAA APPROVED AIRPLANE FLIGHT MANUAL
SUPPLEMENT
for the**

**28-Volt Electrothermal Propeller Deice
(2- and 3-Blade System)**

GENERAL

The information in this supplement is FAA approved material and must be attached to the Pilot's Operating Handbook and FAA Approved Airplane Flight Manual when the airplane is equipped with a 28-Volt Electrothermal Propeller Deice System that has been installed in accordance with Beech-approved data.

This document supersedes or adds to the Pilot's Operating Handbook and FAA Approved Airplane Flight Manual only where covered in the items contained herein.

LIMITATIONS

Do not operate the system unless engine is operating.

EMERGENCY PROCEDURES

LOSS OF ALTERNATOR

Propeller Deice Switch - Off

**FAA Approved
Issued: April, 1978
P/N 36-590002-29**

ABNORMAL READING ON PROPELLER DEICE AMMETER

1. *Zero amps*

Check propeller deice system switch. If the circuit breaker in the switch has tripped, wait 30 seconds before resetting to the ON position. If the ammeter reads 0 after 90 seconds and the switch has not tripped (or after the switch has been reset) turn the switch off and consider the system inoperative.

2. *Zero to 8 amps (2 blade) Zero to 14 amps (3 blade)*

If propeller deice system ammeter occasionally or regularly indicates less than 8 amps (2 blade) or 14 amps (3 blade), operation of the propeller deice system can continue unless serious propeller imbalance results from irregular ice throw-offs.

3. *More than 12 amps (2 blade) More than 18 amps (3 blade)*

If propeller deice system ammeter occasionally or regularly indicates more than 12 amps (2 blade) or 18 amps (3 blade), the system should not be operated unless the need for propeller deice is urgent.

NORMAL PROCEDURES

PREFLIGHT

1. With the engine running, place the propeller deice switch in the ON position.

2. Check propeller deice ammeter for reading of 8 to 12 amps (2 blade) or 14 to 18 amps (3 blade). A reading in the green arc indicates the system is operating.

NOTE

The system is designed to cycle on and off in 90-second intervals. After heating for 90 seconds (with the ammeter indicating in the green arc) the system will cycle off for 90 seconds with no load showing on the ammeter.

IN FLIGHT

1. To place the system in operation, move the propeller deice switch to the ON position. The system will function automatically until the switch is turned off.
2. Propeller imbalance may be relieved by varying rpm. Increase rpm briefly and return to desired setting, repeating as necessary.

PERFORMANCE - No Change.

SYSTEMS DESCRIPTION

The 28-volt Electrothermal Propeller Deice system is an option intended for use in the event icing conditions are inadvertently encountered. This airplane is not approved for flight into icing conditions even with anti-ice or deice equipment installed.

Electrothermal boots, cemented to the propeller blades, are heated by the airplane's 28-volt power supply. Two slip rings on the propeller spinner are contacted by brush blocks to

FAA Approved
Issued: April, 1978
P/N 36-590002-29

complete the circuit. A circuit-breaker-type on/off switch on the subpanel controls the system through an electronic timer which cycles the system for 90-second intervals of operation. A green arc on the propeller deice ammeter provides a range of normal operation while the system is heating the blades. Between heat cycles, the ammeter needle will indicate a no-load condition. Each time the system is turned on the timer will begin a new 90 second heat cycle. If icing is suspected, the system should be turned on and left on until it is certain the icing areas have been evaded. On the ground, the system should not be turned on unless the engine is running.

Approved

for *Donald H. Peter*
Chester A. Rembleske
Beech Aircraft Corporation
DOA CE-2

**BEECHCRAFT BONANZA F33A, F33C, V35B and A36
LANDPLANES**

**PILOT'S OPERATING HANDBOOK AND FAA APPROVED
AIRPLANE FLIGHT MANUAL SUPPLEMENT
for the
KING KNS 80 INTEGRATED NAVIGATION SYSTEM**

GENERAL

The information in this supplement is FAA-approved material and must be attached to the FAA Approved Airplane Flight Manual when the airplane has been modified by installation of the King KNS-80 Navigation System in accordance with Beech-approved data.

The information in this supplement supersedes or adds to the basic FAA Approved Airplane Flight Manual only as set forth within this document. Users of this manual are advised always to refer to the supplement for possibly superseding information and placarding applicable to operation of the airplane.

LIMITATIONS

1. The Area Navigation mode may not be used as a primary system under IFR conditions except on approved approach procedures, approved airways, and random area navigation routes when approved by Air Traffic Control.
2. The Area Navigation mode can only be used with collocated facilities (VOR and DME signals originate from the same geographical location).
3. VOR or VOR-PAR modes must be selected when flying directly to or from a VORTAC facility.

**FAA Approved
Issued August, 1978
P/N 35-590118-43**

EMERGENCY PROCEDURES

CAUTION

DME may unlock due to loss of signal with certain combinations of distance from station, altitude and angle of bank.

1. If NAV flag appears while in the Area Navigation mode, check for correct frequency.
2. If VOR or DME equipment is intermittent or lost, utilize other navigation equipment as required.
3. If NAV flag appears during an approach, execute published missed approach and utilize another approved facility.

NORMAL PROCEDURES

PREFLIGHT

AREA NAVIGATION FUNCTIONAL TEST

The following procedure applies only to airports equipped with, or in range of, a colocated VOR/DME station.

1. Place the KNS-80 in VOR mode.
2. Find and record the angle to the VOR station by centering the D-Bar with a TO TO/FROM flag.
3. Program a waypoint radial angle 120° greater than the indicated VOR radial.

FAA Approved
Issued August, 1978
P/N 35-590118-43

4. Program a waypoint distance equal to the indicated DME value.
5. Place the KNS-80 in RNAV ENR.
6. Rotate the OBS until the D-Bar centers with a TO flag.

The KNS-80 distance-to-station should now read a value equal to the DME distance ($\pm .5\text{NM}$) and the indicated selected course should read 60° greater than the recorded VOR angle to station.

PROGRAMMING

Pertinent information (waypoint number, station frequency, waypoint bearing, and waypoint distance) for up to four waypoints is entered into the memory from the control unit. Programming may be completed prior to takeoff or during the flight. Any combination of navigational facilities (RNAV waypoint, VOR/DME, ILS) may be loaded into the computer; however, it is desirable that each facility be numbered and loaded in the sequence it is to be used.

RNAV WAYPOINTS

1. Turn the system on by rotating the ON/OFF switch clockwise.
2. Put waypoint 1 in the DSP window by depressing the DSP button. Push button as many times as necessary to go through the 1-2-3-4-1 sequence to reach "1".
3. Select the waypoint 1 frequency using the data input controls which are the two concentric knobs on the right.
4. Select the waypoint 1 radial by depressing the DATA button. This will cause the radial for the previous waypoint 1

FAA Approved
Issued August, 1978
P/N 35-590118-43

to appear over the annunciation RAD. Select the new radial with the data input controls.

5. Select the waypoint 1 distance by again depressing the DATA button. This will cause the distance for the previous waypoint 1 to appear over the annunciation DST. Select the new distance with the data input controls.

6. This completes the programming for the first waypoint. Follow these procedures for all selected waypoints up to a maximum of four.

CONVENTIONAL VOR

The programming technique for conventional navigation directly toward or away from a VOR facility without a colocated DME is similar to that for RNAV waypoints. Inputting the waypoint number and frequency into the memory is accomplished in the same manner. Since the station has no DME, it cannot be electronically "moved" to a new location (waypoint). Therefore, no values are programmed in the RAD or DST displays.

ILS APPROACH (Front course and Back course)

Programming an ILS approach is accomplished in the same manner as programming conventional VOR.

MISSED APPROACH

If the published missed approach utilizes an RNAV waypoint or VOR facility, it may be entered into the memory any time prior to the approach. This is accomplished in the same manner set forth in CONVENTIONAL VOR and RNAV WAYPOINTS in this section.

FAA Approved
Issued August, 1978
P/N 35-590116-43

INFLIGHT

Preset waypoints may be recalled from memory and put into active use as required.

1. Press the DSP button as required to select the desired waypoint. The preset waypoint frequency will replace the active waypoint frequency on the display. The selected waypoint number will appear (blinking) over the DSP annunciation. This blinking display is to indicate that the frequency displayed is other than the active waypoint. The waypoint radial and distance may also be checked at this time by pressing the DSP button for each.

2. Verify that the data is correct.

NOTE

Revisions to the waypoint data can be programmed at this time by entering the new waypoint parameters.

3. When navigation to the displayed waypoint is desired, press the USE button. The waypoint number will appear above the USE annunciation on the display board and the number above the DSP annunciation will cease blinking. The new waypoint frequency will automatically appear.

NOTE

When "Time To Station" indicates "0" actual time may be anything from 0 to 59 seconds.

RNAV OPERATION

If the system is receiving valid signals from a collocated VOR-LOC facility, it will supply linear deviation information to the Horizontal Situation Indicator (or Course Deviation Indicator). Enroute (RNV ENR) sensitivity, available by pressing the RNAV button, provides a constant course width of ± 5 NM. Approach (RNV APR) sensitivity, available by pushing the RNAV button again, provides a constant course width of $\pm 1\frac{1}{4}$ NM. Approach sensitivity should be used when within 10 miles of the terminal waypoint. Time and distance to the waypoint, and computed groundspeed are displayed at the top of the display panel.

CONVENTIONAL VOR OPERATION

VOR or VOR-PAR modes are selected by pressing the VOR button; once for VOR and a second time for VOR-PAR. In VOR mode DME is automatically tuned, and distance, groundspeed and time-to-station to the VORTAC station will be displayed upon lock-on. The HSI (CDI) will display conventional angular crosstrack deviation from the selected course ($\pm 10^\circ$ full scale). In VOR-PAR mode operation is identical to VOR except the HSI (CDI) will display crosstrack deviation of ± 5 NM full scale from the selected course. Course width will be constant irrespective of distance from the VORTAC.

ILS OPERATION

The ILS mode is annunciated whenever an ILS frequency is put "in use". LOC/GS functions are annunciated by the LOC and GS flags in the HSI (CDI). Only angular deviation is provided in the ILS mode.

DME HOLD OPERATION

The DME Hold (HLD) function inhibits changing the DME

FAA Approved
Issued August, 1978
P/N 35-590118-43

receiver frequency. Pressing the HOLD button and then selecting a new waypoint forces the KNS-80 into either a conventional VOR or ILS mode of operation according to the newly selected frequency.

Engage DME HOLD as follows:

1. Press the HOLD button.
2. Select the new frequency using the data input controls. HLD will now annunciate. Distance will continue to be read to the VORTAC and information to the HSI (CDI) will be from the newly selected station.

RNAV APPROACH

The RNAV Approach (RNV-APR) mode may be used for runway location (by placing a waypoint at the approach end of the runway) during an approach to an airport. Press the RNAV button to select RNV-APR. In RNV-APR the deviation needle on the HSI (CDI) will display crosstrack deviation of $\pm 1\frac{1}{4}$ NM full scale. All other aspects of the RNV-APR mode are identical to the RNV-ENR mode.

PERFORMANCE - No change

WEIGHT AND BALANCE - No change

SYSTEMS DESCRIPTION

The King KNS-80 is an integrated navigation system combining a 200 channel VOR/Localizer receiver, a 40 channel glideslope receiver, a 200 channel DME, and a digital RNAV computer with a capability for preselection and

FAA Approved
Issued August, 1978
P/N 35-590118-43

7 of 14

storage of 4 VOR/LOC frequencies and RNAV waypoint parameters.

The KNS-80 can be operated in any one of three basic modes: VOR, RNAV, or ILS. To change from one mode to another the appropriate pushbutton switch is pressed, except that the ILS mode is entered automatically whenever an ILS frequency is channeled in the USE waypoint. The display will announce the mode by lighting a message above the pushbutton. In addition to the standard VOR and RNAV enroute (RNV ENR) modes, the KNS-80 has a constant width or parallel VOR mode (VOR-PAR) and an RNAV approach mode (RNV APR). To place the unit in either of these secondary modes, the VOR pushbutton or the RNAV pushbutton, as the case may be, is pushed a second time. Repetitive pushing of the VOR button will cause the system to alternate between the VOR and VOR-PAR modes, while repetitive pushing of the RNAV button causes the system to alternate between RNV ENR and RNV APR modes.

All waypoint information, station frequency, waypoint distance, and waypoint radial are entered with the increment/decrement rotary switch on the right side of the panel and displayed in the right hand readout. The small knob affects the lower significant digits while the large knob changes the most significant digits. The tenth's position of waypoint radial and distance can be changed by pulling the small knob to the out position. The type of data being displayed is indicated by the illuminated messages (FRQ, RAD, DST) located directly below the displayed data. Frequency, radial, or distance information for a waypoint can be displayed sequentially by pressing the "DATA" pushbutton. The increment/decrement switch changes only the information being displayed.

The KNS-80 can store frequency, radial, and distance information for up to four waypoints. The waypoint number of

FAA Approved
Issued August, 1978
P/N 35-590118-43

the data being displayed is located above the message DSP. The DSP waypoint number is changed by pressing the DSP button. The number of the waypoint being used for navigation is indicated by the number above the message USE. If the waypoint in use is different from the displayed waypoint, the DSP waypoint number blinks. Pressing the USE button causes the waypoint in use to match the displayed waypoint.

Normally, the DME is tuned to the station paired with the VOR frequency. The tuning of the DME may be frozen by depressing the HOLD button. Subsequent rechanneling of the NAV receiver will cause the HLD light to illuminate. The DME will "hold" the frequency it was tuned to at the time the button was depressed.

DISPLAYS

1. NM Display

a. VOR and VOR-PAR modes

Displays DME distance in 0.1 NM increments from 0 to 99.9 NM and in 1 NM increments from 100 to 200 NM. Displays dashes whenever DME goes into search.

b. RNAV APR and RNAV ENR modes

Displays RNAV distance to waypoint in 0.1 NM increments from 0 to 99.9 NM and in 1 NM increments from 100 to 400 NM. Displays dashes if DME is in search, if VOR flags, or if the VOR is rechanneled with the HOLD button depressed.

2. KT Display

a. VOR and VOR-PAR modes

Displays ground speed to the DME ground station in 1 knot increments from 0 to 999 knots. Displays dashes whenever DME goes into search.

b. RNV APR and RNV ENR modes

Displays ground speed to the active waypoint in increments of 1 knot from 0 to 999 knots. Displays dashes whenever DME goes into search, if VOR flags or if the VOR is rechanneled with the HOLD button depressed.

3. MIN Display

a. VOR and VOR-PAR modes

Displays time to DME ground station in 1 minute increments from 0 to 99 minutes. Displays dashes whenever DME goes into search or when calculated time exceeds 99 minutes.

b. RNV APR and RNV ENR modes

Displays time to the active waypoint in 1 minute increments from 0 to 99 minutes. Displays dashes if DME is in search, if VOR flags, if the VOR is rechanneled with the HOLD button depressed, or if calculated time exceeds 99 minutes.

4. FRQ, RAD, DST Display

a. FRQ mode

Displays frequency from 108.00 to 117.95 MHz in

FAA Approved
Issued August, 1978
P/N 35-590118-43

increments of .05 MHz. Least significant digit displays only zero or five.

b. RAD mode

Displays ground station radial on which waypoint is located from 0.0 to 359.9 degrees.

c. DST mode

Displays the offset distance of the waypoint from the ground station over a range of 0.0 to 199.9 NM.

5. USE Display

Displays waypoint number of data (1 to 4) actually being used by the system. In VOR modes only the frequency has meaning. When changed, always takes on DSP value.

6. DSP Display

Displays waypoint number (1 to 4) of data being displayed.

7. PAR, VOR, ENR, APR, RNV Displays

System status lights.

8. HLD Display

Indicates when the station to which the DME is actually tuned is different than the station to which the VOR is tuned.

9. DATA Display

Displays waypoint data. The messages FRQ, DST, and

RAD tell what is being displayed at any one time.

10. ILS Display

Indicates that the frequency in use is an ILS frequency.

CONTROL

1. VOR Button

Momentary pushbutton which, when pushed while the system is in either RNV mode, causes the the system to go to VOR mode. Otherwise the button causes the system to toggle between VOR and VOR-PAR modes.

2. RNAV Button

Momentary pushbutton which, when pushed while the system is in either VOR mode, causes the system to go to RNV ENR mode. Otherwise the button causes the system to toggle between RNV ENR and RNV APR modes.

3. HOLD Button

Two position pushbutton which, when in the depressed position, inhibits DME from channeling to a new station when the VOR frequency is changed. Pushing the button again releases the button and channels the DME to the station paired with the VOR station.

4. USE Button

Momentary pushbutton which, when pressed, causes the active waypoint to take on the same value as the displayed waypoint and the DATA display to go to FRQ mode.

FAA Approved
Issued August, 1978
P/N 35-590118-43

5. DSP Button

Momentary pushbutton which, when pushed, causes displayed waypoint to increment by 1 and DATA display to go to FREQUENCY mode.

6. DATA Button

Momentary pushbutton which, when pressed, causes waypoint DATA display to change from FRQ to RAD to DST and back to FRQ.

7. OFF/PULL ID Control

Rotary switch/potentiometer which, when turned clockwise, applies power to the KNS-80 and increases audio level. Turned counterclockwise it will decrease audio level and switch off power. The switch may be pulled out to hear VOR ident.

8. DATA INPUT Control

Dual concentric knobs with the center knob having an "in" and "out" position.

a. Frequency Data

The outer knob varies the 1MHz digit and the center knob varies the frequency in .05 MHz increments regardless of whether the switch is in its "in" or "out" position.

b. Radial Data

The outer knob varies the 10 degree digit with a carryover occurring from the tens to hundreds position. The center knob in the "in" position varies

the 1 degree digit and in the "out" position varies the 0.1 degree digit.

c. Distance Data

The outer knob varies the 10 NM digit with a carryover occurring from the tens to hundreds place. The center knob in the "in" position varies the 1 NM digit and in the "out" position varies the 0.1 NM digit.

HANDLING SERVICE AND MAINTENANCE

BATTERY REPLACEMENT

The waypoint memory is powered by two silver oxide watch cells located in the lower left hand corner of the front panel. Typical life of the cells is two years although high temperature and humidity conditions can shorten this period. If the batteries should become weak, waypoint storage will be lost and the radio will "wake up" tuned to 110.00 MHz in the VOR mode. The cells can be replaced by opening the battery pocket with a thin blade screwdriver. The holder was designed so that the cells can only be inserted with the correct polarity.

APPROVED:

for *Donald St. Peter*

Chester A. Rembleske
Beech Aircraft Corporation
DOA CE-2

**BEECHCRAFT V35B, F33A, F33C, and A36
LANDPLANES
PILOT'S OPERATING HANDBOOK
and
FAA APPROVED AIRPLANE FLIGHT MANUAL
SUPPLEMENT
for the
STANDBY GENERATOR POWER SYSTEM
(28 Volt Electrical System)**

GENERAL

The information in this supplement is FAA approved material and must be attached to the Pilot's Operating Handbook and FAA Approved Airplane Flight Manual when the airplane is equipped with the Standby Generator Power System.

The information in this supplement supersedes or adds to the basic Pilot's Operating Handbook and FAA Approved Airplane Flight Manual only as set forth below.

LIMITATIONS

The system is to be used only in the event of an alternator failure.

Maintain a minimum of 2300 rpm during system operation.

EMERGENCY PROCEDURES

1. With a loss of electrical power from the alternator, turn the Battery and Alternator Switches - OFF
2. Move the Standby Generator Switch to the RESET position and release to the ON position.

**FAA Approved
Issued: October, 1978
P/N 33-590009-25**

3. Select NAV/COMM I or NAV/COMM II.
4. The Standby Generator Power System will operate ONLY the following items:
 - a. Engine Instruments and Fuel Gages
 - b. Electric Turn Coordinator
 - c. Transponder (if installed)
 - d. Audio Amplifier (if installed)
 - e. NAV/COMM I or NAV/COMM II
 - f. Standby Bus Voltmeter
 - g. One glaeshield flood light and Standby Generator Panel edgelight.

NOTE

If an electric compass system is installed and the standby generator system is in operation, no directional gyro indication will be available unless a second air driven directional gyro is installed.

5. Failure of any one instrument indicates a malfunction in that system only.
6. A reading of 24 volts or less on the standby bus voltmeter indicates the standby generator is inoperative.
 - a. Move the standby generator switch to the RESET position, then release to the ON position. The standby bus voltmeter should indicate 28 volts.
 - b. If the standby bus voltmeter continues to indicate 24 volts or less, leave the standby generator switch in the ON position. This will provide battery power to the instruments on the standby bus. Electrical load should be reduced as much as possible to conserve battery power.

7. When the Standby Generator Power System is in use, the landing gear must be extended manually.

NORMAL PROCEDURES

In the BEFORE TAKE-OFF check list, the standby generator TEST procedure follows the magneto check:

1. Throttle - 2300 RPM
2. Battery and Alternator Switches - OFF
3. Standby Generator Switch - ON (The standby bus voltmeter should indicate 24 volts.)
4. Standby Generator Switch - RESET MOMENTARILY, THEN RELEASE TO ON POSITION (The standby bus voltmeter should indicate 28 volts.)
5. Standby Generator Switch - OFF
6. Battery and Alternator Switches - ON

PERFORMANCE - No Change

SYSTEMS

The standby generator power system provides electrical power to the standby bus in the event of an alternator failure. The standby bus provides power to preselected instruments and lights necessary for continued flight.

A 28-volt, self-exciting, gear-driven standby generator is mounted on the accessory pad on the rear of the engine. This generator is controlled by a spring-loaded, three-position toggle switch, placarded OFF-ON-RESET, located on the instrument panel.

When the standby generator switch is placed in the ON position, battery power only (not standby generator power) is

FAA Approved
Issued: October, 1978
P/N 33-590009-25

supplied to the standby bus.

When the standby generator switch is momentarily placed in the RESET position, then released to the ON position, the standby generator circuit is activated and the standby bus is energized by power from the standby generator as well as battery power.

System voltage is monitored by a standby bus voltmeter adjacent to the standby generator switch.

NOTE

No provision is made for recharging the airplane battery using the Standby Generator Power System.

HANDLING, SERVICING AND MAINTENANCE - No Change

Approved:

for *Donald St Rites*
Chester A. Rembleske
Beech Aircraft Corporation
DOA CE-2

Beechcraft

Bonanza

F33A

CE-674 and After

ACROBATIC F33C

CJ-129 and After

(See Flight Manual Supplement)

PILOT'S OPERATING HANDBOOK AND FAA APPROVED AIRPLANE FLIGHT MANUAL

FAA APPROVED IN UTILITY CATEGORY BASED ON CAR 3. THIS DOCUMENT MUST BE CARRIED IN THE AIRPLANE AT ALL TIMES AND BE KEPT WITHIN REACH OF THE PILOT DURING ALL FLIGHT OPERATIONS.

THIS HANDBOOK INCLUDES THE MATERIAL REQUIRED TO BE FURNISHED TO THE PILOT BY CAR 3.

Mfr's Serial No. _____

Registration No. _____

FAA Approved by: 

W. H. SCHULTZ
BEECH AIRCRAFT CORPORATION
DOA CE-2

THIS HANDBOOK SUPERSEDES ALL BEECH PUBLISHED OWNER'S MANUALS, FLIGHT MANUALS, AND CHECK LISTS ISSUED FOR THIS AIRPLANE WITH THE EXCEPTION OF FAA APPROVED AIRPLANE FLIGHT MANUAL SUPPLEMENTS.

COPYRIGHT © BEECH 1990

P/N 33-590009-13
Issued: October, 1976

P/N 33-590009-13A10
Revised: October, 1990

**BONANZA F33A/F33C
(CE-674 AND AFTER; CJ-129 AND AFTER)
PILOT'S OPERATING HANDBOOK
AND**

FAA APPROVED AIRPLANE FLIGHT MANUAL

A10 Revision October, 1990

LOG OF REVISIONS

Page	Description
Title Page	Updated
Page A (A10)	New
10-1 thru 10-48	Revised Section X, Safety Information (October, 1990)

A10

Beechcraft
Single Engine (Piston)

SECTION X
SAFETY INFORMATION
TABLE OF CONTENTS

<i>SUBJECT</i>	<i>PAGE</i>
Introduction	10-3
General	10-5
Do's	10-5
Don'ts	10-6
Sources of Information	10-7
Pilot's Operating Handbook and FAA Approved Airplane Flight Manual	10-7
BEECHCRAFT Service Publications	10-8
Federal Aviation Regulations	10-10
Airworthiness Directives	10-10
Airman's Information Manual	10-10
Advisory Information	10-11
FAA Advisory Circulars	10-12
FAA General Aviation News	10-15
FAA Accident Prevention Program	10-15
Additional Information	10-18
General Information on Specific Topics	10-17
Maintenance	10-17
Hazards of Unapproved Modifications	10-19
Flight Planning	10-20
Passenger Information Cards	10-20
Stowage of Articles	10-21
Flight Operations	10-21
General	10-21
Preflight Inspection	10-21
Weight and Balance	10-22
Autopilots and Electric Trim Systems	10-23
Flutter	10-26
Turbulent Weather	10-27
Wind Shear	10-30
Weather Radar	10-30
Mountain Flying	10-32
VFR - Low Ceilings	10-33
VFR at Night	10-33
Vertigo - Disorientation	10-34
May, 1994	10-1

SECTION X
SAFETY INFORMATION
TABLE OF CONTENTS (Continued)

<i>SUBJECT</i>	<i>PAGE</i>
Stalls, Slow Flight and Training	10-36
Spins	10-36
Descent	10-38
Vortices - Wake Turbulence	10-39
Takeoff and Landing Conditions	10-40
Medical Facts for Pilots	10-40
General	10-40
Fatigue	10-41
Hypoxia	10-41
Hyperventilation	10-43
Alcohol	10-43
Drugs	10-45
Scuba Diving	10-45
Carbon Monoxide and Night Vision	10-45
Decompression Sickness	10-46
A Final Word	10-47

INTRODUCTION

Beech Aircraft Corporation has developed this special summary publication of safety information to refresh pilots' and owners' knowledge of safety related subjects. Topics in this publication are dealt with in more detail in FAA Advisory Circulars and other publications pertaining to the subject of safe flying.

The skilled pilot recognizes that safety consciousness is an integral - and never-ending - part of his or her job. Be thoroughly familiar with your airplane. Know its limitations and your own. Maintain your currency, or fly with a qualified instructor until you are current and proficient. Practice emergency procedures at safe altitudes and airspeeds, preferably with a qualified instructor pilot, until the required action can be accomplished without reference to the manual. Periodically review this safety information as part of your recurrency training regimen.

BEECHCRAFT airplanes are designed and built to provide you with many years of safe and efficient transportation. By maintaining your BEECHCRAFT properly and flying it prudently you will realize its full potential.

..... Beech Aircraft Corporation

WARNING

Because your airplane is a high performance, high speed transportation vehicle, designed for operation in a three-dimensional environment, special safety precautions must be observed to reduce the risk of fatal or serious injuries to the pilot(s) and occupant(s).

It is mandatory that you fully understand the contents of this publication and the other operating and maintenance manuals which accompany the airplane; that FAA requirements for ratings, certifications and review be scrupulously complied with; and that you allow only persons who are properly licensed and rated, and thoroughly familiar with the contents of the Pilot's Operating Handbook and FAA Approved Airplane Flight Manual to operate the airplane.

IMPROPER OPERATION OR MAINTENANCE OF AN AIRPLANE, NO MATTER HOW WELL BUILT INITIALLY, CAN RESULT IN CONSIDERABLE DAMAGE OR TOTAL DESTRUCTION OF THE AIRPLANE, ALONG WITH SERIOUS OR FATAL INJURIES TO ALL OCCUPANTS.

GENERAL

As a pilot, you are responsible to yourself and to those who fly with you, to other pilots and their passengers and to people on the ground, to fly wisely and safely.

The following material in this Safety Information publication covers several subjects in limited detail. Here are some condensed Do's and Don'ts.

DO'S

Be thoroughly familiar with your airplane, know its limitations and your own.

Be current in your airplane, or fly with a qualified instructor until you are current. Practice until you are proficient.

Preplan all aspects of your flight - including a proper weather briefing and adequate fuel reserves.

Use services available - weather briefing, inflight weather and Flight Service Station.

Carefully preflight your airplane.

Use the approved checklist.

Have more than enough fuel for takeoff, plus the trip, and an adequate reserve.

Be sure your weight and C.G. are within limits.

Use seatbelts and shoulder harnesses at all times.

Be sure all loose articles and baggage are secured.

Check freedom and proper direction of operation of all controls during preflight inspection.

Maintain the prescribed airspeeds in takeoff, climb, descent, and landing.

Avoid wake turbulence (Vortices).

Preplan fuel and fuel tank management before the actual flight. Utilize auxiliary tanks only in level cruise flight. Take off and land on the fullest main tank, NEVER use auxiliary tanks for takeoff or landing.

Practice emergency procedures at safe altitudes and air-speeds, preferably with a qualified instructor pilot, until the required action can be accomplished without reference to the manual.

Keep your airplane in good mechanical condition.

Stay informed and alert; fly in a sensible manner.

DON'TS

Don't take off with frost, ice or snow on the airplane.

Don't take off with less than minimum recommended fuel, plus adequate reserves, and don't run the tank dry before switching.

Don't fly in a reckless, show-off, or careless manner.

Don't fly into thunderstorms or severe weather.

Don't fly in possible icing conditions.

Don't fly close to mountainous terrain.

Don't apply controls abruptly or with high forces that could exceed design loads of the airplane.

Don't fly into weather conditions that are beyond your ratings or current proficiency.

Don't fly when physically or mentally exhausted or below par.

Don't trust to luck.

SOURCES OF INFORMATION

There is a wealth of information available to the pilot created for the sole purpose of making your flying safer, easier and more efficient. Take advantage of this knowledge and be prepared for an emergency in the event that one should occur.

PILOT'S OPERATING HANDBOOK AND FAA APPROVED AIRPLANE FLIGHT MANUAL

You must be thoroughly familiar with the contents of your operating manuals, placards, and check lists to ensure safe utilization of your airplane. When the airplane was manufactured, it was equipped with one or more of the following: placards, Owner's Manual, FAA Approved Airplane Flight Manual, FAA Approved Airplane Flight Manual Supplements, Pilot's Operating Handbook and FAA Approved Airplane Flight Manual. Beech has revised and reissued many of the early manuals for certain models of airplanes in GAMA Standard Format as Pilot's Operating Handbooks and FAA Approved Airplane Flight Manuals. For simplicity and convenience, all official manuals in various models are referred to as the Pilot's Operating Handbook and FAA Approved Airplane Flight Manual. If the airplane has changed ownership, the Pilot's Operating Handbook and FAA Approved Airplane Flight Manual may have been misplaced or may not be current. Replacement handbooks may be obtained from any BEECHCRAFT Authorized Outlet.

BEECHCRAFT SERVICE PUBLICATIONS

Beech Aircraft Corporation publishes a wide variety of manuals, service letters, service instructions, service bulletins, safety communiques and other publications for the various models of BEECHCRAFT airplanes. Information on how to obtain publications relating to your airplane is contained in BEECHCRAFT Service Bulletin number 2001, entitled "General - BEECHCRAFT Service Publications - What Is Available and How to Obtain It."

Beech Aircraft Corporation automatically mails original issues and revisions of BEECHCRAFT Service Bulletins (Mandatory, Recommended and Optional), FAA Approved Airplane Flight Manual Supplements, reissues and revisions of FAA Approved Airplane Flight Manuals, Flight Handbooks, Owners Manuals, Pilot's Operating Manuals and Pilot's Operating Handbooks, and original issues and revisions of BEECHCRAFT Safety Communiques to BEECHCRAFT Owner addresses as listed by the FAA Aircraft Registration Branch List and the BEECHCRAFT International Owner Notification Service List. While this information is distributed by Beech Aircraft Corporation, Beech can not make changes in the name or address furnished by the FAA. The owner must contact the FAA regarding any changes to name or address. Their address is: FAA Aircraft Registration Branch (AAC250) P.O. Box 25082, Oklahoma City, OK 73125, Phone (405) 680-2131.

It is the responsibility of the FAA owner of record to ensure that any mailings from Beech are forwarded to the proper persons. Often the FAA registered owner is a bank or financing company or an individual not in possession of the airplane. Also, when an airplane is sold, there is a lag in processing the change in registration with the FAA. If you are a new owner, contact your BEECHCRAFT Authorized Outlet and ensure your manuals are up to date.

Beech Aircraft Corporation provides a subscription service which provides for direct factory mailing of BEECHCRAFT

publications applicable to a specific serial number airplane. Details concerning the fees and ordering information for this owner subscription service are contained in Service Bulletin number 2001.

For owners who choose not to apply for a Publications Revision Subscription Service, Beech provides a free Owner Notification Service by which owners are notified by post card of BEECHCRAFT manual reissues, revisions and supplements which are being issued applicable to the airplane owned. On receipt of such notification, the owner may obtain the publication through a BEECHCRAFT Authorized Outlet. This notification service is available when requested by the owner. This request may be made by using the owner notification request card furnished with the loose equipment of each airplane at the time of delivery, or by a letter requesting this service, referencing the specific airplane serial number owned. Write to:

Supervisor, Special Services
Dept. 52
Beech Aircraft Corporation
P.O. Box 85
Wichita, Kansas 67201-0085

From time to time Beech Aircraft Corporation issues BEECHCRAFT Safety Communiques dealing with the safe operation of a specific series of airplanes, or airplanes in general. It is recommended that each owner/operator maintain a current file of these publications. Back issues of BEECHCRAFT Safety Communiques may be obtained without charge by sending a request, including airplane model and serial number, to the Supervisor, Special Services, at the address listed above.

Airworthiness Directives (AD's) are not issued by the manufacturer. They are issued and available from the FAA.

FEDERAL AVIATION REGULATIONS

FAR Part 91, General Operating and Flight Rules, is a document of law governing operation of airplanes and the owner's and pilot's responsibilities. Some of the subjects covered are:

Responsibilities and authority of the pilot-in-command

Certificates required

Liquor and drugs

Flight plans

Preflight action

Fuel requirements

Flight rules

Maintenance, preventive maintenance, alterations, inspection and maintenance records

You, as a pilot, have responsibilities under government regulations. The regulations are designed for your protection and the protection of your passengers and the public. Compliance is mandatory.

AIRWORTHINESS DIRECTIVES

FAR Part 39 specifies that no person may operate a product to which an Airworthiness Directive issued by the FAA applies, except in accordance with the requirements of that Airworthiness Directive.

AIRMAN'S INFORMATION MANUAL

The Airman's Information Manual (AIM) is designed to provide airmen with basic flight information and ATC procedures for use in the national airspace system of the United States. It also contains items of interest to pilots concerning health and medical facts, factors affecting flight safety, a pilot/controller glossary of terms in the Air Traffic Control

system, information on safety, and accident/hazard reporting. It is revised at six-month intervals and can be purchased from the Superintendent of Documents, U.S. Government Printing Office, Washington, D.C. 20402.

This document contains a wealth of pilot information. Among the subjects are:

Controlled Airspace
Emergency Procedures
Services Available to Pilots
Weather and Icing
Radio Phraseology and Technique
Mountain Flying
Airport Operations
Wake Turbulence - Vortices
Clearances and Separations
Medical Facts for Pilots
Preflight
Bird Hazards
Departures - IFR
Good Operating Practices
En route - IFR
Airport Location Directory
Arrival - IFR

All pilots must be thoroughly familiar with and use the information in the AIM.

ADVISORY INFORMATION

NOTAMS (Notices to Airmen) are documents that have information of a time-critical nature that would affect a pilot's decision to make a flight; for example, an airport closed, terminal radar out of service, or enroute navigational aids out of service.

FAA ADVISORY CIRCULARS

The FAA issues Advisory Circulars to inform the aviation public in a systematic way of nonregulatory material of interest. Advisory Circulars contain a wealth of information with which the prudent pilot should be familiar. A complete list of current FAA Advisory Circulars is published in AC 00-2, which lists Advisory Circulars that are for sale, as well as those distributed free of charge by the FAA, and provides ordering information. Many Advisory Circulars which are for sale can be purchased locally in aviation bookstores or at FBO's. These documents are subject to periodic revision. Be certain the Advisory Circular you are using is the latest revision available. Some of the Advisory Circulars of interest to pilots are:

- *00-8** Aviation Weather
- 00-24** Thunderstorms
- 00-30** Rules of Thumb for Avoiding or Minimizing Encounters with Clear Air Turbulence
- *00-45** Aviation Weather Services
- 00-46** Aviation Safety Reporting Program
- 20-5** Plane Sense
- 20-32** Carbon Monoxide (CO) Contamination In Aircraft - Detection and Prevention
- 20-35** Tie-Down Sense
- 20-43** Aircraft Fuel Control
- 20-105** Engine Power-Loss Accident Prevention
- 20-113** Pilot Precautions and Procedures to be Taken in Preventing Aircraft Reciprocating Engine Induction System & Fuel System Icing Problems
- 20-125** Water in Aviation Fuel

- 21-4** Special Flight Permits for Operation of Overweight Aircraft
- 43-9** Maintenance Records: General Aviation Aircraft
- 43-12** Preventive Maintenance
- 60-4** Pilot's Spatial Disorientation
- 60-6** Airplane Flight Manuals (AFM), Approved Manual Materials, Markings and Placards - Airplanes
- 60-12** Availability of Industry-Developed Guidelines for the Conduct of the Biennial Flight Review
- 60-13** The Accident Prevention Counselor Program
- *61-9** Pilot Transition Courses for Complex Single-Engine and Light Twin-Engine Airplanes
- *61-21** Flight Training Handbook
- *61-23** Pilot's Handbook of Aeronautical Knowledge
- *61-27** Instrument Flying Handbook
- 61-67** Hazards Associated with Spins in Airplanes Prohibited from Intentional Spinning.
- 61-84** Role of Preflight Preparation
- *67-2** Medical Handbook for Pilots
- 90-23** Aircraft Wake Turbulence
- 90-42** Traffic Advisory Practices at Nontower Airports

**Section X
Safety Information**

**Deerecraft
Single Engine (Piston)**

- 90-48 Pilot's Role In Collision Avoidance
- 90-66 Recommended Standard Traffic Patterns for Airplane Operations at Uncontrolled Airports
- 90-85 Severe Weather Avoidance Plan (SWAP)
- 91-6 Water, Slush and Snow on the Runway
- 91-13 Cold Weather Operation of Aircraft
- 91-23 Pilot's Weight and Balance Handbook
- 91-25 Maintenance and Handling of Air Driven Gyroscopic Instruments
- 91-33 Use of Alternate Grades of Aviation Gasoline for Grade 80/87 and Use of Automotive Gasoline
- 91-35 Noise, Hearing Damage, and Fatigue In General Aviation Pilots
- 91-43 Unreliable Airspeed Indications
- 91-44 Operational and Maintenance Practices for Emergency Locator Transmitters and Receivers
- 91-46 Gyroscopic Instruments - Good Operating Practices
- 91-50 Importance of Transponder Operations and Altitude Reporting
- 91-51 Airplane Deice and Anti-Ice Systems
- 91-59 Inspection and Care of General Aviation Aircraft Exhaust Systems
- 91-65 Use of Shoulder Harness in Passenger Seats

103-4 Hazards Associated with Sublimation of Solid Carbon Dioxide (Dry Ice) Aboard Aircraft

210-5A Military Flying Activities

* For Sale

FAA GENERAL AVIATION NEWS

FAA General Aviation News is published by the FAA in the interest of flight safety. The magazine is designed to promote safety in the air by calling the attention of general aviation airmen to current technical, regulatory and procedural matters affecting the safe operation of airplanes. FAA General Aviation News is sold on subscription by the Superintendent of Documents, Government Printing Office, Washington D.C., 20402.

FAA ACCIDENT PREVENTION PROGRAM

The FAA assigns accident prevention specialists to each Flight Standards and General Aviation District Office to organize accident prevention program activities. In addition, there are over 3,000 volunteer airmen serving as accident prevention counselors, sharing their technical expertise and professional knowledge with the general aviation community. The FAA conducts seminars and workshops, and distributes invaluable safety information under this program.

Usually the airport manager, the FAA Flight Service Station (FSS), or Fixed Base Operator (FBO), will have a list of accident prevention counselors and their phone numbers available. All Flight Standards and General Aviation District Offices have a list of the counselors serving the District.

Before flying over unfamiliar territory, such as mountainous terrain or desert areas, it is advisable for transient pilots to consult with local counselors. They will be familiar with the

more desirable routes, the wind and weather conditions, and the service and emergency landing areas that are available along the way. They can also offer advice on the type of emergency equipment you should be carrying.

ADDITIONAL INFORMATION

The National Transportation Safety Board and the Federal Aviation Administration periodically issue, in greater detail, general aviation pamphlets concerning aviation safety. FAA Regional Offices also publish material under the FAA General Aviation Accident Prevention Program. These can be obtained at FAA Offices, Weather Stations, Flight Service Stations or Airport Facilities. Some of these are titled:

- 12 Golden Rules for Pilots
- Weather or Not
- Disorientation
- Plane Sense
- Weather Info Guide for Pilots
- Wake Turbulence
- Don't Trust to Luck, Trust to Safety
- Rain, Fog, Snow
- Thunderstorm - TRW
- Icing
- Pilot's Weather Briefing Guide
- Thunderstorms Don't Flirt ... Skirt 'em
- IFR-VFR - Either Way Disorientation Can Be Fatal
- IFR Pilot Exam-O-Grams
- VFR Pilot Exam-O-Grams
- Tips on Engine Operation in Small General Aviation Aircraft
- Estimating Inflight Visibility
- is the Aircraft Ready for Flight
- Tips on Mountain Flying
- Tips on Desert Flying
- Always Leave Yourself An Out

Safety Guide for Private Aircraft Owners
Tips on How to Use the Flight Planner
Tips on the Use of Ailerons and Rudder
Some Hard Facts About Soft Landings
Propeller Operation and Care
Torque "What It Means to the Pilot"
Weight and Balance, An Important Safety Consideration for Pilots

GENERAL INFORMATION ON SPECIFIC TOPICS

MAINTENANCE

Safety of flight begins with a well maintained airplane. Make it a habit to keep your airplane and all its equipment in airworthy condition. Keep a "squawk list" on board, and see that all discrepancies, however minor, are noted and promptly corrected.

Schedule your maintenance regularly, and have your airplane serviced by a reputable organization. Be suspicious of bargain prices for maintenance, repair and inspections.

It is the responsibility of the owner and the operator to assure that the airplane is maintained in an airworthy condition and that proper maintenance records are kept.

Use only genuine BEECHCRAFT or BEECHCRAFT approved parts obtained from BEECHCRAFT approved sources, in connection with the maintenance and repair of Beech airplanes.

Genuine BEECHCRAFT parts are produced and inspected under rigorous procedures to insure airworthiness and suitability for use in Beech airplane applications. Parts purchased from sources other than BEECHCRAFT, even though outwardly identical in appearance, may not have had

Section X
Safety Information

Beechcraft
Single Engine (Piston)

the required tests and inspections performed, may be different in fabrication techniques and materials, and may be dangerous when installed in an airplane.

Salvaged airplane parts, reworked parts obtained from non-BEECHCRAFT approved sources or parts, components, or structural assemblies, the service history of which is unknown or cannot be authenticated, may have been subjected to unacceptable stresses or temperatures or have other hidden damage not discernible through routine visual or usual nondestructive testing techniques. This may render the part, component, or structural assembly, even though originally manufactured by BEECHCRAFT, unsuitable and unsafe for airplane use.

BEECHCRAFT expressly disclaims any responsibility for malfunctions, failures, damage or injury caused by use of non-BEECHCRAFT parts.

Airplanes operated for Air Taxi or other than normal operation, and airplanes operated in humid tropics, or cold and damp climates, etc., may need more frequent inspections for wear, corrosion and/or lack of lubrication. In these areas, periodic inspections should be performed until the operator can set his own inspection periods based on experience.

NOTE

The required periods do not constitute a guarantee that the item will reach the period without malfunction, as the aforementioned factors cannot be controlled by the manufacturer.

Corrosion and its effects must be treated at the earliest possible opportunity. A clean, dry surface is virtually immune to corrosion. Make sure that all drain holes remain unobstructed. Protective films and sealants help to keep corrosive agents from contacting metallic surfaces. Corrosion

Inspections should be made most frequently under high-corrosion-risk operating conditions, such as in areas of excessive airborne salt concentrations (e.g., near the sea) and in high-humidity areas (e.g., tropical regions).

If you have purchased a used airplane, have your mechanic inspect the airplane registration records, logbooks and maintenance records carefully. An unexplained period of time for which the airplane has been out of service, or unexplained significant repairs may well indicate the airplane has been seriously damaged in a prior accident. Have your mechanics inspect a used airplane carefully. Take the time to ensure that you really know what you are buying when you buy a used airplane.

HAZARDS OF UNAPPROVED MODIFICATIONS

Many airplane modifications are approved under Supplemental Type Certificates (STC's). Before installing an STC on your airplane, check to make sure that the STC does not conflict with other STC's that have already been installed. Because approval of an STC is obtained by the individual STC holder based upon modification of the original type design, it is possible for STC's to interfere with each other when both are installed. Never install an unapproved modification of any type, however innocent the apparent modification may seem. Always obtain proper FAA approval.

Airplane owners and maintenance personnel are particularly cautioned not to make attachments to, or otherwise modify, seats from original certification without approval from the FAA Engineering and Manufacturing District Office having original certification responsibility for that make and model.

Any unapproved attachment or modification to seat structure may increase load factors and metal stress which could cause failure of seat structure at a lesser "G" force than exhibited for original certification.

Examples of unauthorized attachments found are drilling holes in seat tubing to attach fire extinguishers and drilling holes to attach approach plate book bins to seats.

FLIGHT PLANNING

FAR Part 91 requires that each pilot in command, before beginning a flight, familiarize himself with all available information concerning that flight.

Obtain a current and complete preflight briefing. This should consist of local, enroute and destination weather and enroute navigational information. Enroute terrain and obstructions, alternate airports, airport runways active, length of runways, and takeoff and landing distances for the airplane for conditions expected should be known.

The prudent pilot will review his planned enroute track and stations and make a list for quick reference. It is strongly recommended a flight plan be filed with Flight Service Stations, even though the flight may be VFR. Also, advise Flight Service Stations of changes or delays of one hour or more and remember to close the flight plan at destination.

The pilot must be completely familiar with the performance of the airplane and performance data in the Pilot's Operating Handbook and FAA Approved Airplane Flight Manual. The resultant effect of temperature and pressure altitude must be taken into account in performance if not accounted for on the charts. An applicable FAA Approved Airplane Flight Manual must be aboard the airplane at all times and include the weight and balance forms and equipment list.

PASSENGER INFORMATION CARDS

Beech has available, for most current production airplanes, passenger information cards which contain important information on the proper use of restraint systems, oxygen

masks, emergency exits and emergency bracing procedures. Passenger information cards may be obtained at any BEECHCRAFT Authorized Outlet. A pilot should not only be familiar with the information contained in the cards, but should always, prior to flight, inform the passengers of the information contained in the information cards. The pilot should orally brief the passengers on the proper use of restraint systems, doors and emergency exits, and other emergency procedures, as required by Part 91 of the FAR's.

STOWAGE OF ARTICLES

The space between the seat pan and the floor is utilized to provide space for seat displacement. If hard, solid objects are stored beneath seats, the energy absorbing feature is lost and severe spinal injuries can occur to occupants.

Prior to flight, pilots should insure that articles are not stowed beneath seats that would restrict seat pan energy absorption or penetrate the seat in event of a high vertical velocity accident.

FLIGHT OPERATIONS

GENERAL

The pilot **MUST** be thoroughly familiar with **ALL INFORMATION** published by the manufacturer concerning the airplane, and is required by law to operate the airplane in accordance with the FAA Approved Airplane Flight Manual and placards installed.

PREFLIGHT INSPECTION

In addition to maintenance inspections and preflight information required by FAR Part 91, a complete, careful preflight inspection is imperative.

Each airplane has a checklist for the preflight inspection which must be followed. **USE THE CHECKLIST.**

WEIGHT AND BALANCE

Maintaining center of gravity within the approved envelope throughout the planned flight is an important safety consideration.

The airplane must be loaded so as not to exceed the weight and center of gravity (C.G.) limitations. Airplanes that are loaded above the maximum takeoff or landing weight limitations will have an overall lower level of performance compared to that shown in the Performance section of the Pilot's Operating Handbook and FAA Approved Airplane Flight Manual. If loaded above maximum takeoff weight, takeoff distance and the landing distance will be longer than that shown in the Performance section; the stalling speed will be higher, rate of climb, the cruising speed, and the range of the airplane at any level of fuel will all be lower than shown in the Performance section.

If an airplane is loaded so that the C.G. is forward of the forward limit, it will require additional control movements for maneuvering the airplane with correspondingly higher control forces. The pilot may have difficulty during takeoff and landing because of the elevator control limits.

If an airplane is loaded aft of the aft C.G. limitation, the pilot will experience a lower level of stability. Airplane characteristics that indicate a lower stability level are: lower control forces, difficulty in trimming the airplane, lower control forces for maneuvering with attendant danger of structural overload, decayed stall characteristics, and a lower level of lateral-directional damping.

Ensure that all cargo and baggage is properly secured before takeoff. A sudden shift in balance at rotation can cause controllability problems.

AUTOPILOTS AND ELECTRIC TRIM SYSTEMS

Because there are several different models of autopilots and electric trim systems installed in Beech airplanes and different installations and switch positions are possible from airplane to airplane, it is essential that every owner/operator review his Airplane Flight Manual (AFM) Supplements and ensure that the supplements properly describe the autopilot and trim installations on his specific airplane. Each pilot, prior to flight, must be fully aware of the proper procedures for operation, and particularly disengagement, for the system as installed.

In addition to ensuring compliance with the autopilot manufacturer's maintenance requirements, all owners/operators should thoroughly familiarize themselves with the operation, function and procedures described in the Airplane Flight Manual Supplements. Ensure a full understanding of the methods of engagement and disengagement of the autopilot and trim systems.

Compare the descriptions and procedures contained in the Supplements to the actual installation in the airplane to ensure that the supplement accurately describes your installation. Test that all buttons, switches and circuit breakers function as described in the Supplements. If they do not function as described, have the system repaired by a qualified service agency. If field service advice or assistance is necessary, contact Beech Aircraft Corporation, Customer Support Department.

As stated in all AFM Supplements for autopilot systems and trim systems installed on Beech airplanes, the preflight check must be conducted before every flight. The preflight check assures not only that the systems and all of their features are operating properly, but also that the pilot, before flight, is familiar with the proper means of engagement and disengagement of the autopilot and trim system.

Autopilot Airplane Flight Manual Supplements caution against trying to override the autopilot system during flight without disengaging the autopilot because the autopilot will continue to trim the airplane and oppose the pilot's actions. This could result in a severely out of trim condition. This is a basic feature of all autopilots with electric trim follow-up.

Do not try to manually override the autopilot during flight.

IN CASE OF EMERGENCY, YOU CAN OVERPOWER THE AUTOPILOT TO CORRECT THE ATTITUDE, BUT THE AUTOPILOT AND ELECTRIC TRIM MUST THEN IMMEDIATELY BE DISENGAGED.

It is often difficult to distinguish an autopilot malfunction from an electric trim system malfunction. The safest course is to deactivate both. Do not re-engage either system until after you have safely landed. Then have the systems checked by a qualified service facility prior to further flight.

Depending upon the installation on your airplane, the following additional methods may be available to disengage the autopilot or electric trim in the event that the autopilot or electric trim does not disengage utilizing the disengage methods specified in the Supplements.

CAUTION

Transient control forces may occur when the autopilot is disengaged.

1. Turn off the autopilot master switch, if installed.
2. Pull the autopilot and trim circuit breaker(s) or turn off the autopilot switch breaker, if installed.
3. Turn off the RADIO MASTER SWITCH, if installed, and if the autopilot system and the trim system are wired through this switch.

CAUTION

Radios, including VHF COMM are also disconnected when the radio master switch is off.

4. Turn off the ELECTRIC MASTER SWITCH.

WARNING

Almost all electrically powered systems will be inoperative. Consult the AFM for further information.

5. Push the GA switch on throttle grip, if installed (depending upon the autopilot system).
6. Push TEST EACH FLT switch on the autopilot controller, if installed.

NOTE

After the autopilot is positively disengaged, it may be necessary to restore other electrical functions. Be sure when the master switches are turned on that the autopilot does not re-engage.

The above ways may or may not be available on your autopilot. It is essential that you read your airplane's AFM SUPPLEMENT for your autopilot system and check each function and operation on your system.

The engagement of the autopilot must be done in accordance with the instructions and procedures contained in the AFM SUPPLEMENT.

Particular attention must be paid to the autopilot settings prior to engagement. If you attempt to engage the autopilot when the airplane is out of trim, a large attitude change may occur.

IT IS ESSENTIAL THAT THE PROCEDURES SET FORTH IN THE APPROVED AFM SUPPLEMENTS FOR YOUR SPECIFIC INSTALLATION BE FOLLOWED BEFORE ENGAGING THE AUTOPILOT.

FLUTTER

Flutter is a phenomenon that can occur when an aerodynamic surface begins vibrating. The energy to sustain the vibration is derived from airflow over the surface. The amplitude of the vibration can (1) decrease, if airspeed is reduced; (2) remain constant, if airspeed is held constant and no failures occur; or (3) increase to the point of self-destruction, especially if airspeed is high and/or is allowed to increase. Flutter can lead to an in-flight break up of the airplane. Airplanes are designed so that flutter will not occur in the normal operating envelope of the airplane as long as the airplane is properly maintained. In the case of any airplane, decreasing the damping and stiffness of the structure or increasing the trailing edge weight of control surfaces will tend to cause flutter. If a combination of those factors is sufficient, flutter can occur within the normal operating envelope.

Owners and operators of airplanes have the primary responsibility for maintaining their airplanes. To fulfill that responsibility, it is imperative that all airplanes receive a thorough preflight inspection. Improper tension on the control cables or any other loose condition in the flight control system can also cause or contribute to flutter. Pilots should pay particular attention to control surface attachment hardware including tab pushrod attachment during preflight inspection. Looseness of fixed surfaces or movement of control surfaces other than in the normal direction of travel should be

rectified before flight. Further, owners should take their airplanes to mechanics who have access to current technical publications and prior experience in properly maintaining that make and model of airplane. The owner should make certain that control cable tension inspections are performed as outlined in the applicable Beech Inspection Guide. Worn control surface attachment hardware must be replaced. Any repainting or repair of a moveable control surface will require a verification of the control surface balance before the airplane is returned to service. Control surface drain holes must be open to prevent freezing of accumulated moisture, which could create an increased trailing-edge-heavy control surface and flutter.

If an excessive vibration, particularly in the control column and rudder pedals, is encountered in flight, this may be the onset of flutter and the procedure to follow is:

1. IMMEDIATELY REDUCE AIRSPEED (lower the landing gear if necessary).
2. RESTRAIN THE CONTROLS OF THE AIRPLANE UNTIL THE VIBRATION CEASES.
3. FLY AT THE REDUCED AIRSPEED AND LAND AT THE NEAREST SUITABLE AIRPORT.
4. HAVE THE AIRPLANE INSPECTED FOR AIRFRAME DAMAGE, CONTROL SURFACE ATTACHING HARDWARE CONDITION/SECURITY, TRIM TAB FREE PLAY, PROPER CONTROL CABLE TENSION, AND CONTROL SURFACE BALANCE BY ANOTHER MECHANIC WHO IS FULLY QUALIFIED.

TURBULENT WEATHER

A complete and current weather briefing is a requirement for a safe trip.

Updating of weather information enroute is also essential. The wise pilot knows that weather conditions can change

quickly, and treats weather forecasting as professional advice, rather than an absolute fact. He obtains all the advice he can, but stays alert to any sign or report of changing conditions.

Plan the flight to avoid areas of reported severe turbulence. It is not always possible to detect individual storm areas or find the in-between clear areas.

The National Weather Service classifies turbulence as follows:

Class of Turbulence	Effect
Extreme	Airplane is violently tossed about and is practically impossible to control. May cause structural damage.
Severe	Airplane may be momentarily out of control. Occupants are thrown violently against the belts and back into the seat. Unsecured objects are tossed about.
Moderate	Occupants require seat belts and occasionally are thrown against the belt. Unsecured objects move about.
Light	Occupants may be required to use seat belts, but objects in the airplane remain at rest.

Thunderstorms, squall lines and violent turbulence should be regarded as extremely dangerous and must be avoided. Hail and tornadic wind velocities can be encountered in thunderstorms that can destroy any airplane, just as tornadoes destroy nearly everything in their path on the ground.

Thunderstorms also pose the possibility of a lightning strike on an airplane. Any structure or equipment which shows evidence of a lightning strike, or of being subjected to a high

current flow due to a strike, or is a suspected part of a lightning strike path through the airplane should be thoroughly inspected and any damage repaired prior to additional flight.

A roll cloud ahead of a squall line or thunderstorm is visible evidence of extreme turbulence; however, the absence of a roll cloud should not be interpreted as denoting that severe turbulence is not present.

Even though flight in severe turbulence must be avoided, flight in turbulent air may be encountered unexpectedly under certain conditions.

The following recommendations should be observed for airplane operation in turbulent air:

Flying through turbulent air presents two basic problems, the answer to both of which is proper airspeed. On one hand, if you maintain an excessive airspeed, you run the risk of structural damage or failure; on the other hand, if your airspeed is too low, you may stall.

If turbulence is encountered, reduce speed to the turbulent air penetration speed, if given, or to the maneuvering speed, which is listed in the Limitations section of the Pilot's Operating Handbook and FAA Approved Airplane Flight Manual. These speeds give the best assurance of avoiding excessive stress loads, and at the same time provide the proper margin against inadvertent stalls due to gusts.

Beware of overcontrolling in an attempt to correct for changes in attitude; applying control pressure abruptly will build up G-forces rapidly and could cause structural damage or even failure. You should watch particularly your angle of bank, making turns as wide and shallow as possible. Be equally cautious in applying forward or back pressure to keep the airplane level. Maintain straight and level attitude in either up or down drafts. Use trim sparingly to avoid being

grossly out of trim as the vertical air columns change velocity and direction. If necessary to avoid excessive airspeeds, lower the landing gear.

WIND SHEAR

Wind shears are rapid, localized changes in wind direction, which can occur vertically as well as horizontally. Wind shear can be very dangerous to all airplanes, large and small, particularly on approach to landing when airspeeds are slow.

A horizontal wind shear is a sudden change in wind direction or speed that can, for example, transform a headwind into a tailwind, producing a sudden decrease in indicated airspeed because of the inertia of the airplane. A vertical wind shear, is a sudden updraft or downdraft. Microbursts are intense, highly localized severe downdrafts.

The prediction of wind shears is far from an exact science. Monitor your airspeed carefully when flying near storms, particularly on approach. Be mentally prepared to add power and go around at the first indication that a wind shear is being encountered.

WEATHER RADAR

Airborne weather avoidance radar is, as its name implies, for avoiding severe weather—not for penetrating it. Whether to fly into an area of radar echoes depends on echo intensity, spacing between the echoes, and the capabilities of you and your airplane. Remember that weather radar detects only precipitation drops; it does not detect turbulence. Therefore, the radar scope provides no assurance of avoiding turbulence. The radar scope also does not provide assurance of avoiding instrument weather due to clouds and fog. Your scope may be clear between intense echoes; this clear area does not necessarily mean you can fly between the storms and maintain visual sighting of them.

Thunderstorms build and dissipate rapidly. Therefore, do not attempt to plan a course between echoes using ground based radar. The best use of ground radar information is to isolate general areas and coverage of echoes. You must avoid individual storms from in-flight observations either by visual sighting or by airborne radar. It is better to avoid the whole thunderstorm area than to detour around individual storms unless they are scattered.

Remember that while hail always gives a radar echo, it may fall several miles from the nearest visible cloud and hazardous turbulence may extend to as much as 20 miles from the echo edge. Avoid intense or extreme level echoes by at least 20 miles; that is, such echoes should be separated by at least 40 miles before you fly between them. With weaker echoes you can reduce the distance by which you avoid them.

Above all, remember this: never regard any thunderstorm lightly. Even when radar observers report the echoes are of light intensity, avoiding thunderstorms is the best policy. The following are some do's and don'ts of thunderstorm avoidance:

1. Don't land or take off in the face of an approaching thunderstorm. A sudden gust front of low level turbulence could cause loss of control.
2. Don't attempt to fly under a thunderstorm even if you can see through to the other side. Turbulence and wind shear under the storm could be disastrous.
3. Don't fly without airborne radar into a cloud mass containing scattered embedded thunderstorms. Embedded thunderstorms usually can not be visually circumnavigated.
4. Don't trust visual appearance to be a reliable indicator of the turbulence inside a thunderstorm.

5. Do avoid by at least 20 miles any thunderstorm identified as severe or giving an intense radar echo. This is especially true under the anvil of a large cumulonimbus.
6. Do circumnavigate the entire area if the area has 6/10 or greater thunderstorm coverage.
7. Do remember that vivid and frequent lightning indicates the probability of a severe thunderstorm.
8. Do regard as extremely hazardous any thunderstorm with tops 35,000 feet or higher, whether the top is visually sighted or determined by radar.

If you cannot avoid penetrating a thunderstorm, the following are some do's BEFORE entering the storm:

9. Tighten your safety belt, put on your shoulder harness, and secure all loose objects.
10. Plan and hold your course to take you through the storm in minimum time.
11. To avoid the most critical icing, establish a penetration altitude below the freezing level or above the level of -15°C .
12. Verify that pitot heat is on and turn on carburetor heat or engine anti-ice. Icing can be rapid at any altitude and cause almost instantaneous power failure and/or loss of airspeed indication.

MOUNTAIN FLYING

Pilots flying in mountainous areas should inform themselves of all aspects of mountain flying, including the effects of topographic features on weather conditions. Many good articles have been published, and a synopsis of mountain flying operations is included in the FAA Airmen's Information Manual, Part 1.

Avoid flight at low altitudes over mountainous terrain, particularly near the lee slopes. If the wind velocity near the

level of the ridge is in excess of 25 knots and approximately perpendicular to the ridge, mountain wave conditions are likely over and near the lee slopes. If the wind velocity at the level of the ridge exceeds 50 knots, a strong mountain wave is probable with extreme up and down drafts and severe turbulence. The worst turbulence will be encountered in and below the rotor zone, which is usually 8 to 10 miles downwind from the ridge. This zone is sometimes characterized by the presence of "roll clouds" if sufficient moisture is present; altocumulus standing lenticular clouds are also visible signs that a mountain wave exists, but their presence is likewise dependent on moisture. Mountain wave turbulence can, of course, occur in dry air and the absence of such clouds should not be taken as assurance that mountain wave turbulence will not be encountered. A mountain wave downdraft may exceed the climb capability of your airplane. Avoid mountain wave downdrafts.

VFR - LOW CEILINGS

If you are not instrument rated, do not attempt "VFR on Top" or "Special VFR" flight or clearances. Being caught above a solid cloud layer when an emergency descent is required (or at destination) is an extremely hazardous position for the VFR pilot. Accepting a clearance out of airport control zones with no minimum ceiling and one-mile visibility as permitted with "Special VFR" is a foolish practice for the VFR pilot.

Avoid areas of low ceilings and restricted visibility unless you are instrument rated and proficient and have an instrument equipped airplane. Then proceed with caution and with planned alternates.

VFR AT NIGHT

When flying VFR at night, in addition to the altitude appropriate for the direction of flight, pilots should maintain a safe minimum altitude as dictated by terrain, obstacles such as

TV towers, or communities in the area flown. This is especially true in mountainous terrain, where there is usually very little ground reference. Minimum clearance is 2,000 feet above the highest obstacle enroute. Do not depend on your ability to see obstacles in time to miss them. Flight on dark nights over sparsely populated country can be the same as IFR, and must be avoided by inexperienced or non-IFR rated pilots.

VERTIGO - DISORIENTATION

Disorientation can occur in a variety of ways. During flight, inner ear balancing mechanisms are subjected to varied forces not normally experienced on the ground. This, combined with loss of outside visual reference, can cause vertigo. False interpretations (illusions) result, and may confuse the pilot's conception of the attitude and position of his airplane.

Under VFR conditions, the visual sense, using the horizon as a reference, can override the illusions. Under low visibility conditions (night, fog, clouds, haze, etc.) the illusions predominate. Only through awareness of these illusions, and proficiency in instrument flight procedures, can an airplane be operated safely in a low visibility environment.

Flying in fog, dense haze or dust, cloud banks, or very low visibility, with strobe lights or rotating beacons turned on can contribute to vertigo. They should be turned off in these conditions, particularly at night.

All pilots should check the weather and use good judgment in planning flights. The VFR pilot should use extra caution in avoiding low visibility conditions.

Motion sickness often precedes or accompanies disorientation and may further jeopardize the flight.

Disorientation in low visibility conditions is not limited to VFR pilots. Although IFR pilots are trained to look at their instruments to gain an artificial visual reference as a replacement for the loss of a visual horizon, they do not always do so. This can happen when the pilot's physical condition will not permit him to concentrate on his instruments; when the pilot is not proficient in flying instrument conditions in the airplane he is flying; or, when the pilot's work load of flying by reference to his instruments is augmented by such factors as turbulence. Even an instrument rated pilot encountering instrument conditions, intentional or unintentional, should ask himself whether or not he is sufficiently alert and proficient in the airplane he is flying, to fly under low visibility conditions and in the turbulence anticipated or encountered.

If any doubt exists, the flight should not be made or it should be discontinued as soon as possible.

The result of vertigo is loss of control of the airplane. If the loss of control is sustained, it will result in an excessive speed accident. Excessive speed accidents occur in one of two manners, either as an inflight airframe separation or as a high speed ground impact; and they are fatal accidents in either case. All airplanes are subject to this form of accident.

For years, Beech Pilot's Operating Handbooks and FAA Approved Airplane Flight Manuals have contained instructions that the landing gear should be extended in any circumstance in which the pilot encounters IFR conditions which approach the limits of his capability or his ratings. Lowering the gear in IFR conditions or flight into heavy or severe turbulence, tends to stabilize the airplane, assists in maintaining proper airspeed, and will substantially reduce the possibility of reaching excessive airspeeds with catastrophic consequences, even where loss of control is experienced.

Excessive speed accidents occur at airspeeds greatly in excess of two operating limitations which are specified in the

manuals: Maximum maneuvering speed and the "red line" or "never exceed" speed. Such speed limits are set to protect the structure of an airplane. For example, flight controls are designed to be used to their fullest extent only below the airplane's maximum maneuvering speed. As a result, the control surfaces should never be suddenly or fully deflected above maximum maneuvering speed. Turbulence penetration should not be performed above that speed. The accidents we are discussing here occur at airspeeds greatly in excess of these limitations. No airplane should ever be flown beyond its FAA approved operating limitations.

STALLS, SLOW FLIGHT AND TRAINING

The stall warning system must be kept operational at all times and must not be deactivated by interruption of circuits, circuit breakers, or fuses. Compliance with this requirement is especially important in all high performance single engine airplanes during simulated engine-out practice or stall demonstrations, because the stall speed is critical in all low-speed operation of airplanes.

Training should be accomplished under the supervision of a qualified instructor-pilot, with careful reference to the applicable sections of the FAA Practical Test Standards and FAA Pilot Transition Courses for Complex Single Engine and Light Twin Engine Airplanes (AC 61-9). In particular, observe carefully the warnings in the Practical Test Standards.

SPINS

A major cause of fatal accidents in general aviation airplanes is a spin. Stall demonstrations and practice are a means for a pilot to acquire the skills to recognize when a stall is about to occur and to recover as soon as the first signs of a stall are evident.

If a stall does not occur - A spin cannot occur.

It is important to remember, however, that a stall can occur in any flight attitude, at any airspeed, if controls are misused.

Unless your airplane has been specifically certificated in the aerobatic category and specifically tested for spin recovery characteristics, it is placarded against intentional spins.

The pilot of an airplane placarded against intentional spins should assume that the airplane may become uncontrollable in a spin, since its performance characteristics beyond certain limits specified in the FAA regulations may not have been tested and are unknown. This is why airplanes are placarded against intentional spins, and this is why stall avoidance is your protection against an inadvertent spin.

Pilots are taught that intentional spins are entered by deliberately inducing a yawing moment with the controls as the airplane is stalled. Inadvertent spins result from the same combination - stall plus yaw. That is why it is important to use coordinated controls and to recover at the first indication of a stall when practicing stalls.

Always remember that extra alertness and pilot techniques are required for slow flight maneuvers, including the practice or demonstration of stalls. In addition to the foregoing mandatory procedure, always:

- Be certain that the center of gravity of the airplane is as far forward as possible. Forward C.G. aids stall recovery, spin avoidance and spin recovery. An aft C.G. can create a tendency for a spin to stabilize, which delays recovery.
- Whenever a student pilot will be required to practice slow flight, be certain that the qualified instructor pilot has a full set of operable controls available. FAA regulations prohibit flight instruction without full dual controls.

Section X
Safety Information

Deechcraft
Single Engine (Piston)

- Conduct any maneuvers which could possibly result in a spin at altitudes in excess of five thousand (5,000) feet above ground level in clear air only.
- Remember that an airplane, at or near traffic pattern and approach altitudes, cannot recover from a spin, or perhaps even a stall, before impact with the ground. On final approach maintain at least the airspeed shown in the flight manual.
- Remember that if an airplane flown under instrument conditions is permitted to stall or enter a spin, the pilot, without reference to the horizon, is certain to become disoriented. He may be unable to recognize a stall, spin entry, or the spin condition and he may be unable to determine even the direction of the rotation.
- Finally, never forget that stall avoidance is your best protection against an inadvertent spin. **MAINTAIN YOUR AIRSPEED.**

In airplanes not certificated for aerobatics, spins are prohibited. If a spin is entered inadvertently:

Immediately move the control column full forward and simultaneously apply full rudder opposite to the direction of the spin; continue to hold this position until rotation stops and then neutralize all controls and execute a smooth pullout. Ailerons should be neutral and the throttle in idle position at all times during recovery.

DESCENT

In single engine piston-powered airplanes, supercharged or normally aspirated, it is necessary to avoid prolonged descents with low power, as this produces two problems: (1) excessively cool cylinder head temperatures which cause premature engine wear, and (2) excessively rich mixtures due to idle enrichment (and altitude) which causes soot and lead deposits on the spark plugs (fouling). The second of these is the more serious consideration; the engine may not

respond to the throttle when it is desired to discontinue the descent. Both problems are amenable to one solution: maintain adequate power to keep cylinder head temperature in the "green" range during descent, and lean to best power mixture (that is, progressively enrich the mixture from cruise only slightly as altitude decreases). This procedure will lengthen the descent, of course, and requires some advance planning. If it is necessary to make a prolonged descent at or near idle, as in practicing forced landings, at least avoid the problem of fouled spark plugs by frequently advancing the throttle until the engine runs smoothly, and maintain an appropriate mixture setting with altitude. (Refer to pre-landing check list.)

VORTICES - WAKE TURBULENCE

Every airplane generates wakes of turbulence while in flight. Part of this is from the propeller or jet engine, and part from the wing tip vortices. The larger and heavier the airplane, the more pronounced and turbulent the wakes will be. Wing tip vortices from large, heavy airplanes are very severe at close range, degenerating with time, wind and distance. These are rolling in nature, from each wing tip. In tests, vortex velocities of 133 knots have been recorded. Encountering the rolling effect of wing tip vortices within two minutes after passage of large airplanes is most hazardous to light airplanes. This roll effect can exceed the maximum counter-roll obtainable in a light airplane. The turbulent areas may remain for as long as three minutes or more, depending on wind conditions, and may extend several miles behind the airplane. Plan to fly slightly above and to the windward side of other airplanes. Because of the wide variety of conditions that can be encountered, there is no set rule to follow to avoid wake turbulence in all situations. However, the Airman's Information Manual, and to a greater extent Advisory Circular 90-23, Aircraft Wake Turbulence, provide a thorough discussion of the factors you should be aware of when wake turbulence may be encountered.

TAKEOFF AND LANDING CONDITIONS

When taking off on runways covered with water or freezing slush, the landing gear should remain extended for approximately ten seconds longer than normal, allowing the wheels to spin and dissipate the freezing moisture. The landing gear should then be cycled up, then down, wait approximately five seconds and then retracted again. Caution must be exercised to insure that the entire operation is performed below Maximum Landing Gear Operating Airspeed.

Use caution when landing on runways that are covered by water or slush which cause hydroplaning (aquaplaning), a phenomenon that renders braking and steering ineffective because of the lack of sufficient surface friction. Snow and ice covered runways are also hazardous. The pilot should also be alert to the possibility of the brakes freezing.

Use caution when taking off or landing during gusty wind conditions. Also be aware of the special wind conditions caused by buildings or other obstructions located near the runway.

MEDICAL FACTS FOR PILOTS

GENERAL

When the pilot enters the airplane, he becomes an integral part of the man-machine system. He is just as essential to a successful flight as the control surfaces. To ignore the pilot in preflight planning would be as senseless as failing to inspect the integrity of the control surfaces or any other vital part of the machine. The pilot has the responsibility for determining his reliability prior to entering the airplane for flight. When piloting an airplane, an individual should be free of conditions which are harmful to alertness, ability to make correct decisions, and rapid reaction time.

FATIGUE

Fatigue generally slows reaction time and causes errors due to inattention. In addition to the most common cause of fatigue; insufficient rest and loss of sleep, the pressures of business, financial worries, and family problems can be important contributing factors. If you are tired, don't fly.

HYPOXIA

Hypoxia, in simple terms, is a lack of sufficient oxygen to keep the brain and other body tissues functioning properly. There is a wide individual variation in susceptibility to hypoxia. In addition to progressively insufficient oxygen at higher altitudes, anything interfering with the blood's ability to carry oxygen can contribute to hypoxia (anemias, carbon monoxide, and certain drugs). Also, alcohol and various drugs decrease the brain's tolerance to hypoxia.

Your body has no built-in alarm system to let you know when you are not getting enough oxygen. It is impossible to predict when or where hypoxia will occur during a given flight, or how it will manifest itself. Some of the common symptoms of hypoxia are increased breathing rate, a light-headed or dizzy sensation, tingling or warm sensation, sweating, reduced visual field, sleepiness, blue coloring of skin, fingernails, and lips, and behavior changes. A particularly dangerous feature of hypoxia is an increased sense of well-being, called euphoria. It obscures a person's ability and desire to be critical of himself, slows reaction time, and impairs thinking ability. Consequently, a hypoxic individual commonly believes things are getting progressively better while he nears total collapse.

The symptoms are slow but progressive, insidious in onset, and are most marked at altitudes starting above ten thousand feet. Night vision, however, can be impaired starting at an altitude of 5,000 feet. Persons who have recently overindulged in alcohol, who are moderate to heavy smokers, or

Section X
Safety Information

Cesscraft
Single Engine (Piston)

who take certain drugs, may be more susceptible to hypoxia. Susceptibility may also vary in the same individual from day to day or even morning to evening. Use oxygen on flights above 10,000 feet and at any time when symptoms appear.

Depending upon altitude, a hypoxic individual has a limited time to make decisions and perform useful acts, even though he may remain conscious for a longer period. The time of useful consciousness is approximately 3-5 minutes at 25,000 feet of altitude and diminishes markedly as altitude increases.

Should symptoms occur that cannot definitely be identified as either hypoxia or hyperventilation, try three or four deep breaths of oxygen. The symptoms should improve markedly if the condition was hypoxia (recovery from hypoxia is rapid).

Pilots who fly to altitudes that require or may require the use of supplemental oxygen should be thoroughly familiar with the operation of the airplane oxygen systems. A preflight inspection of the system should be performed, including proper fit of the mask. The passengers should be briefed on the proper use of their oxygen system before flight.

Pilots who wear beards should be careful to ensure that their beard is carefully trimmed so that it will not interfere with proper sealing of the oxygen masks. If you wear a beard or moustache, test the fit of your oxygen mask on the ground for proper sealing. Studies conducted by the military and oxygen equipment manufacturers conclude that oxygen masks do not seal over beards or heavy facial hair.

Federal Aviation Regulations related to the use of supplemental oxygen by flight crew and passengers must be adhered to if flight at higher altitudes is to be accomplished safely. Passengers with significant circulatory or lung disease may need to use supplemental oxygen at lower altitudes than specified by these regulations.

HYPERVENTILATION

Hyperventilation, or overbreathing, is a disturbance of respiration that may occur in individuals as a result of emotional tension or anxiety. Under conditions of emotional stress, fright, or pain, breathing rate may increase, causing increased lung ventilation, although the carbon dioxide output of the body cells does not increase. As a result, carbon dioxide is "washed out" of the blood. The most common symptoms of hyperventilation are: dizziness, nausea, sleepiness, and finally, unconsciousness. If the symptoms persist, discontinue use of oxygen and consciously slow your breathing rate until symptoms clear, and then resume normal breathing rate. Normal breathing can be aided by talking aloud.

ALCOHOL

Common sense and scientific evidence dictate that you must not fly as a crew member while under the influence of alcohol. Alcohol, even in small amounts, produces (among other things):

- A dulling of critical judgement.
- A decreased sense of responsibility.
- Diminished skill reactions and coordination.
- Decreased speed and strength of muscular reflexes (even after one ounce of alcohol).
- Decreases in efficiency of eye movements during reading (after one ounce of alcohol).
- Increased frequency of errors (after one ounce of alcohol).
- Constriction of visual fields.
- Decreased ability to see under dim illuminations.
- Loss of efficiency of sense of touch.
- Decrease of memory and reasoning ability.

Section X
Safety Information

Dechcraft
Single Engine (Piston)

- Increased susceptibility to fatigue and decreased attention span.
- Decreased relevance of response.
- Increased self confidence with decreased insight into immediate capabilities.

Tests have shown that pilots commit major errors of judgment and procedure at blood alcohol levels substantially less than the minimum legal levels of intoxication for most states. These tests further show a continuation of impairment from alcohol up to as many as 14 hours after consumption, with no appreciable diminution of impairment. The body metabolizes ingested alcohol at a rate of about one-third of an ounce per hour. Even after the body completely destroys a moderate amount of alcohol, a pilot can still be severely impaired for many hours by hangover. The effects of alcohol on the body are magnified at altitudes, as 2 oz. of alcohol at 18,000 feet produce the same adverse effects as 6 oz. at sea level.

Federal Aviation Regulations have been amended to reflect the FAA's growing concern with the effects of alcohol impairment. FAR 91 states:

***Alcohol or drugs.**

(a) No person may act or attempt to act as a crew-member of a civil aircraft -

- (1) Within 8 hours after the consumption of any alcoholic beverage;
- (2) While under the influence of alcohol;
- (3) While using any drug that affects the person's faculties in any way contrary to safety; or
- (4) While having .04 percent by weight or more alcohol in the blood.

(b) Except in an emergency, no pilot of a civil aircraft may allow a person who appears to be intoxicated or who demonstrates by manner or physical indications that the individual is under the influence of drugs (except a medical patient under proper care) to be carried in that aircraft."

Because of the slow destruction of alcohol by the body, a pilot may still be under influence eight hours after drinking a moderate amount of alcohol. Therefore, an excellent rule is to allow at least 12 to 24 hours between "bottle and throttle," depending on the amount of alcoholic beverage consumed.

DRUGS

Self-medication or taking medicine in any form when you are flying can be extremely hazardous. Even simple home or over-the-counter remedies and drugs such as aspirin, anti-histamines, cold tablets, cough mixtures, laxatives, tranquilizers, and appetite suppressors, may seriously impair the judgment and coordination needed while flying. The safest rule is to take no medicine before or while flying, except after consultation with your Aviation Medical Examiner.

SCUBA DIVING

Flying shortly after any prolonged scuba diving could be dangerous. Under the increased pressure of the water, excess nitrogen is absorbed into your system. If sufficient time has not elapsed prior to takeoff for your system to rid itself of this excess gas, you may experience the bends at altitudes even under 10,000 feet, where most light planes fly.

CARBON MONOXIDE AND NIGHT VISION

The presence of carbon monoxide results in hypoxia which will affect night vision in the same manner and extent as hypoxia from high altitudes. Even small levels of carbon

monoxide have the same effect as an altitude increase of 8,000 to 10,000 feet. Smoking several cigarettes can result in a carbon monoxide saturation sufficient to affect visual sensitivity equal to an increase of 8,000 feet altitude.

DECOMPRESSION SICKNESS

Pilots flying unpressurized airplanes at altitudes in excess of 10,000 feet should be alert for the symptoms of 'decompression sickness'. This phenomenon, while rare, can impair the pilot's ability to perform and in extreme cases, can result in the victim being rendered unconscious. Decompression sickness, also known as dysbarism and aviators "bends", is caused by nitrogen bubble formation in body tissue as the ambient air pressure is reduced by climbing to higher altitudes. The symptoms are pain in the joints, abdominal cramps, burning sensations in the skin, visual impairment and numbness. Some of these symptoms are similar to hypoxia. The only known remedy for decompression sickness is recompression, which can only be accomplished in an unpressurized airplane by descending. The pilot should immediately descend if it is suspected that this condition exists, since the effects will only worsen with continued exposure to the reduced pressure environment at altitude and could result, if uncorrected, in complete incapacitation. The possibility of decompression sickness can be greatly reduced by pre-breathing oxygen prior to flight and by commencing oxygen breathing well below the altitudes where it is legally mandatory.

A FINAL WORD

Airplanes are truly remarkable machines. They enable us to shrink distance and time, and to expand our business and personal horizons in ways that, not too many years ago, were virtually inconceivable. For many businesses, the general aviation airplane has become the indispensable tool of efficiency.

Advances in the mechanical reliability of the airplanes we fly have been equally impressive, as attested by the steadily declining statistics of accidents attributed to mechanical causes, at a time when the airframe, systems and power plants have grown infinitely more complex. The explosion in capability of avionics systems is even more remarkable. Radar, RNAV, LORAN, sophisticated autopilots and other devices which, just a few years ago, were too large and prohibitively expensive for general aviation size airplanes, are becoming increasingly commonplace in even the smallest airplanes.

It is thus that this Safety Information is directed to the pilot, for it is in the area of the skill and proficiency of you, the pilot, that the greatest gains in safe flying are to be made over the years to come. Intimate knowledge of your airplane, its capabilities and its limitations, and disciplined adherence to the procedures for your airplane's operation, will enable you to transform potential tragedy into an interesting hangar story when - as it inevitably will - the abnormal situation is presented.

Know your airplane's limitations, and your own. Never exceed either.

Safe flying.

BEECH AIRCRAFT CORPORATION